

100  
YEARS OF  
YANMAR  
*1912-2012*

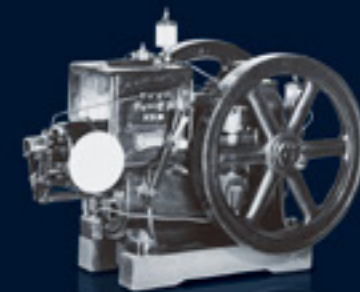

**YANMAR**

100 YEARS OF YANMAR  
*1912-2012*

100  
YEARS OF  
YANMAR  
*1912-2012*

**YANMAR**

# Foreword



On March 22, 2012, Yanmar celebrated the 100th anniversary of its founding. It gives the company great pleasure to now publish the English edition of Yanmar’s 100-year history.

We are eternally grateful to our customers who have offered us their patronage, our business connections who have cooperated with us, and the local communities that have given us their backing for more than a century.

As we look back, this century has been a period of attempting to be of service to people’s work and everyday life and to contribute to local communities and the world at large, by means of developing the type of engines and work machines that are required by the changing times and by various people around the world.

This photograph was taken 90 years ago in 1925 in Sasayama, Hyogo Prefecture. It shows the first powered pump installed in the village vigorously pumping water from the river. Leaders of the village, dressed in their finest for this great event, look on intently. At that time, watering fields by means of physical labor was an enormous burden, so the installation of a powered pump had a huge impact on the welfare of villages like this one.



Water pump powered by a Yanmar oil engine (Sasayama, Hyogo Prefecture, 1925)

After the photo was taken, the company continued to develop oil engines and in 1933 it developed and put into practical use the world’s first small diesel engine. Following World War II, it dedicated all of its energies to the diffusion of diesel engines, to developing diesel-powered, labor-saving, reduced-manpower machinery and to opening new markets around the world for agricultural, marine, construction and industrial uses.

During this century, the company encountered numerous ordeals including wars, postwar confusion, oil crises, trade friction and natural disasters, but our predecessors in the company overcame them with intelligence and strenuous effort.

The business environment which Yanmar finds itself in today is one of great change and the company is facing increasingly serious issues including preserving and harmonizing with the global environment and responding to a globalizing market.

On the occasion of the company’s 100th anniversary, the Yanmar Group has formulated a new Mission Statement. It is the result of the hopes of a project team composed of young employees. While it is expressed in simple words, it matches perfectly the spirit of founder Magokichi Yamaoka: “To conserve fuel is to serve mankind” and “Grateful to serve for a better world.”

It is our goal to have each employee of the Yanmar Group become deeply conscious of this Mission Statement, to consider what we can do for our customers, to have pride in our work and be encouraged in our daily activities, and to strive for solutions to whatever issues arise, and further, to aim to achieve a society with the future in mind and an abundant way of life.

In closing, it is our hope that this history of Yanmar’s first century will enable the reader to grasp the wisdom and the determination of our predecessors and to embody that legacy in new activity. Further, we would be extremely happy if this volume proves helpful in understanding the company’s businesses.

The Yanmar Group kindly asks for your continued good will in the years to come.

**Takehito Yamaoka**  
President of Yanmar Co., Ltd.  
May 2015

---

## Mission Statement

We strive to provide sustainable solutions for needs which are essential to human life.

We focus on the challenges our customers face in food production and harnessing power, thereby enriching people’s lives for all our tomorrows.

---





## Mission Statement



We strive to provide sustainable solutions  
for needs which are essential to human life.

We focus on the challenges our customers face  
in food production and harnessing power,  
thereby enriching people's lives for all our tomorrows.

The K1 engine exhibited in the Deutsches Museum

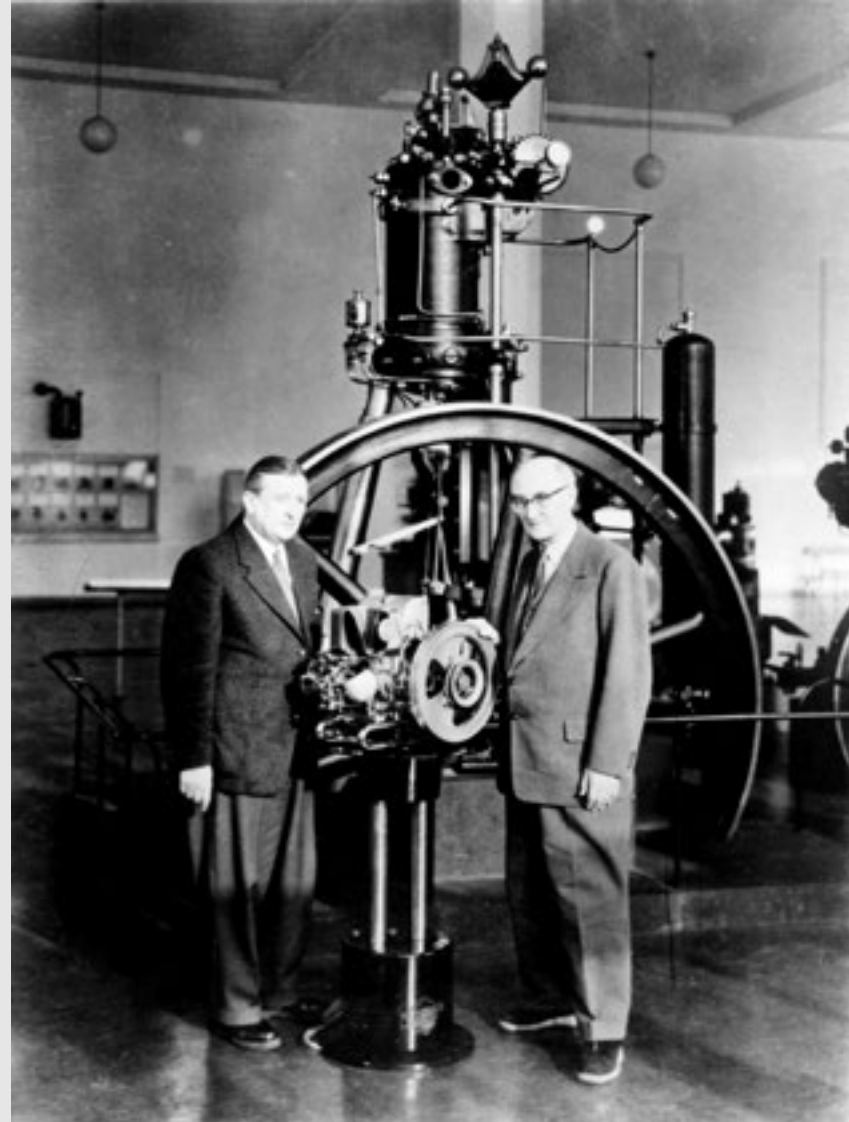

A section model of the K1 engine donated to the Deutsches Museum at their request in 1956. The model was exhibited alongside the very first diesel engine produced by Dr. Diesel. (left,right) Museum representatives



The inventor of the diesel engine  
**Dr. Rudolf Diesel**  
1858–1913



The developer of the world's first  
small diesel engine  
Founder of YANMAR,  
**Magokichi Yamaoka**  
1888–1962

# Contents

Foreword	4
Mission Statement	7

## Chapter 1

### Founding of Yamaoka Hatsudoki Kosakusho 15

---

#### *1912-1931*

From the countryside to Osaka harboring lofty ambitions	17
Establishing Yamaoka Gasu Shokai	19
Founding Yamaoka Hatsudoki Kosakusho, the predecessor of Yanmar	22
Wartime boom and postwar recession	23
Start of a new career as a manufacturer of oil-powered engines	25
Birth of "Yanmar" products	26
Aiming for the diffusion of engines for agricultural use	27
Successive ordeals in expansion of domestic and overseas business	29

## Chapter 2

### Development of the World's First Small Diesel Engine 33

---

#### *1932-1945*

Revelation at the Leipzig Trade Fair	35
After a bitter struggle, the jubilation at a "World's First"	37
Overcoming financial issues to build the Kanzaki Plant	41
Arbitrarily deciding to specialize in diesels	44
Taking "To conserve fuel is to serve mankind" as a fundamental principle	48

## Chapter 3

### A Life Dedicated to Spreading the Diesel 51

---

#### *1945-1963*

Recovery from wartime damage without delay	53
Entrance into the fishing boat engine market	55
Advantages and disadvantages of trade with India	58
Development of the lightest-weight K series	59
Committing all possible effort to securing the agricultural-use engine market	62
Realizing the ideal of rural industry	65
Launching into medium and large engine markets	66
Diesel engines as a bridge of friendship between Japan and Germany	67
Vice President Yasuhito Yamaoka's innovative business expansion	72
The "Second Yanmar" in Brazil	75
Establishment of Yanmar Agricultural Equipment Co., Ltd.	76
The successive deaths of founder and second company president	78

## Chapter 4

### Modernization of Management and Entrance into the Industrial Machinery Market 81

---

#### *1963-1972*

Appointment of Tadao Yamaoka as the third president	83
Awarded the first Deming Prize in the industry for company-wide quality control activities	85
Standardization of the tiller and the tractor business	87
The road to the mechanization of rice production	90
Reaper-binder and combine harvester / Rice transplanter	
Entry into the fiberglass boat business	93

Formation of sales companies nationwide and measures for the agricultural cooperatives sales channel	94
Strengthening of the production system and modernization of facilities	97
Aiming for “Global Yanmar”	99

## Chapter 5

### Overcoming the Era of Low Economic Growth by Energy Conservation and Waste Elimination 101

---

#### *1973-1984*

Development in rapid succession of energy-saving diesel engines	103
The rise of the “ <i>tatesui</i> ,” vertical water-cooled engine	106
Creation and growth of the compact construction equipment market	107
Waste elimination activities and the introduction of a new production system	110
Shiga Production Branch / Amagasaki Plant / VA-VE activities and the “Suggestion System”	
Introduction of a parts information management system	115
Construction of a parts distribution center	116
Establishment of the Yanmar Kyoto Research and Development Center and progress of mechatronics technology	117
Development of a “Dream Product”	118
Cogeneration system / Gas heat pump air-conditioning system / Z drive system / Gas turbine	
Strengthening local production and advancing into the North American market	123

## Chapter 6

### Venturing into New Businesses and Global Expansion 127

---

#### *1985-1997*

Implementing Special Emergency Measures	129
At the mercy of the bubble economy	130
Challenges and failures in new businesses and new products	131

Placing hope in the future of agriculture	133
Responding to the polarization of agriculture and the mechanization of vegetable farming	134
Thriving business in excavator and other compact construction machinery	137
Entrance into the air-conditioning market with GHPs	140
Tackling the emission gas problem	142
Establishment of a strategic production base, the Biwa Plant	145
Expansion of overseas production based on the tri-polar concept	147
The European market / The North American market / The Asian market	
The birth of Cerezo Osaka	152

## Chapter 7

### Implementing Reform Leading Up to the Centennial of the Group’s Founding 153

---

#### *1998-2012*

Takehito Yamaoka becomes the company’s 4th president	155
Reform of operation processes through PDP	157
Introduction of ROA as a management index	159
Introduction of the in-house company system	160
Reorganization of sales companies	161
Carrying out the Yanmar Evolution Plan	162
Agricultural business / Marine business / Construction equipment business / Energy system business / Component business / Industrial engine business / Large marine engine business	
Deployment of YWK activities throughout the Group	174
Establishing a global tri-polar research system	175
Formulating an environmental vision and technological suitability	177
Strengthening small and medium engine environmental efficiency / Strengthening large engine environmental efficiency / Expansion of energy system products	



Reorganization of the American and European businesses following the Lehman Shock 183

Speeding up expansion of operations in the Chinese market 184

Development in Asia and emerging economies 186

Succeeding accumulated history and taking it forward 188

The Great East Japan Earthquake and support for recovery 190

Foundation Centennial and the introduction of a new Mission Statement 191

The Centennial Celebration and commemorative projects 193

Starting off on the next 100-year voyage 196

History of the Yanmar Group 197

Corporate Profile 203

## Founding of Yamaoka Hatsudoki Kosakusho

# 1912-1931

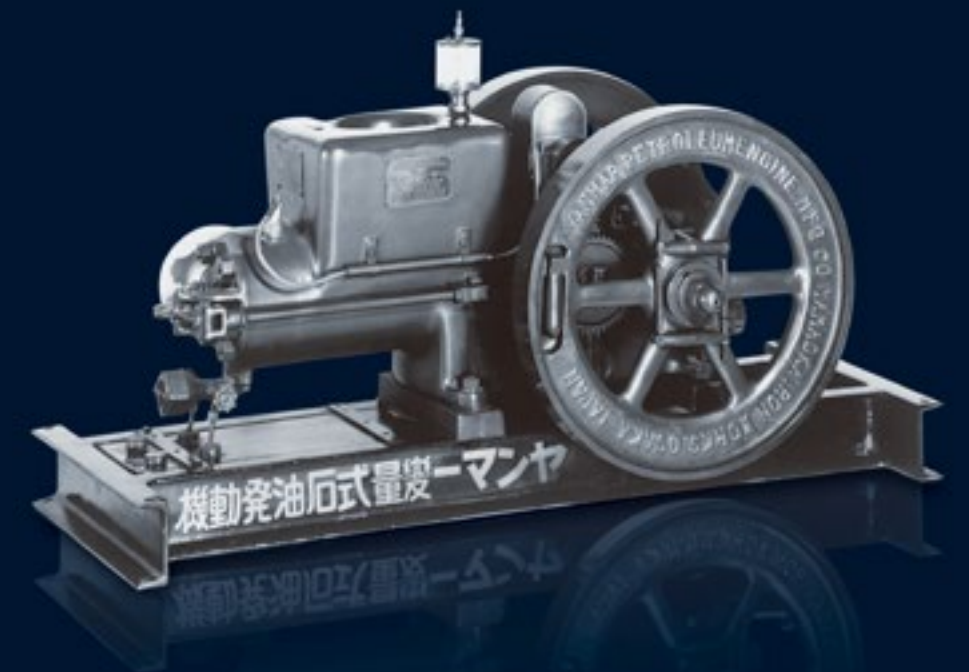

**HISTORICAL BACKGROUND**

As it passed through the Meiji Restoration on its way to becoming a modern nation, Japan got started on the right track by means of the new government's policies, including "enrich the country, strengthen the military" (*fukoku kyohei*) and "increase production and promote industry" (*shokusan kogyo*), achieving rapid industrial development. Government-operated enterprises actively introducing Western industrial technology were established in various parts of the country. Raw silk and cotton goods produced by the Tomioka Silk Mill and the Hiroshima Spinning Mill expanded exports and eventually the silk reeling and spinning industries developed into major enterprises driving the Japanese economy. Before long, these various businesses were transferred to private ownership, and when the textile industry, mines and cement plants passed into private hands, modernization spread into heavy industries such as iron manufacturing and shipbuilding.

Simultaneously, whereas steam engines had long been the main source of power, gas, petroleum and electricity became newly diffused.

The Meiji era gave way to the Taisho era in 1912 and the First World War broke out in 1914, and Japan was flooded with orders for munitions and the wartime economy boomed. Once the war came to an end, a postwar crisis ensued and that, together with the 1923 Great Kanto Earthquake, accelerated the floundering of the economy. Subsequently, with the beginning of the Showa era in 1926, Japan's economy entered a long, dark tunnel marked by the so-called Showa financial crisis in Japan and the collapse of the stock market in New York. The Japanese economy seemed so bogged down that there was hardly a glimmer of light on the horizon.

## From the countryside to Osaka harboring lofty ambitions

In the Kohoku area in Shiga Prefecture, lay the Ibuki Mountain range and an isolated village that looked out over Lake Biwa. No matter where one looked, everything was covered in snow. When a late spring finally arrived and the snow finally melted, all that appeared was a small patch of thin arable land. Unblessed with the conveniences of irrigation or water supplies, the land yielded only a meager harvest, regardless of how much effort went into it. Then the snows came, making the land impenetrable again.

Needless to say, this region could not compare with Tokyo and Osaka, which were steadily progressing down the path of modernization, but it was even poorer and more desolate than the Koto and Konan areas of Shiga Prefecture. The single factor that suggested some degree of modern civilization was the railroad at Nagahama that connected with Tsuruga, a port which traded with the continent.

A young man once stood lost deep in thought as he looked at the narrow dark railroad line stretching across the snowy landscape.

'In this poor village where there is absolutely nothing to do, what kind of future do I have? I wonder what sort of world lies at the other end of that railroad line.'

That young man filled with desire to leave his home province for some unknown destination was none other than our founder, Magokichi Yamaoka.

Magokichi was born on March 22, 1888, in Minami-Tominaga mura, Ika-gun, Shiga Prefecture (present-day Takatsuki-cho, Higashi-Atsuji, Nagahama). He was the sixth son of his father Chuzaburo and his mother Kuni, and the ninth of ten children. His father worked as a carpenter on the side while cultivating a small plot of land roughly 2,000 square meters in size, which he inherited when starting a new family line. It was not easy to earn a livelihood on such a minimal piece of land, especially given the number of children in the family.

In the village, it was common practice for the children, once they had completed primary school, to go off to the city and become an apprentice. However, Chuzaburo had himself served as an apprentice, and hoping to have the robust, diligent Magokichi succeed to the family trade, he was unwilling to let his son go.



The Kohoku area at the beginning of the 20th century



A steam locomotive in the Kohoku area (around 1904)

Seeing the impoverishment of his village and the dire financial straits of his family, and watching the young men of the village leave one after another, Magokichi's unease and impatience worsened. At the same time, his yearning to experience the outside world grew stronger and so intense that he could no longer hold his feelings inside.

Around the young age of 14, two years after attending school for only six years, Magokichi resolved to leave for the United States. There was an emigration boom at that time, and emigration brokerage agencies were loudly clamoring that whoever went to America would become enormously successful. Magokichi was overflowing with enthusiasm, so perhaps it was only natural that since he had decided to leave the village, he might as well go overseas.

Without letting his parents know, he set off on foot for an emigration agency in Hikone, some 25 km distant. When he arrived at the agency, however, what he encountered was completely unexpected.

In order to emigrate, one first of all had to have the permission of one's parents and, second, pay a security deposit of 180 yen. Setting aside getting the consent of his parents, 180 yen was an enormous sum. At that time, a 60 kg bag of rice cost about 3 yen 60 sen, so 180 yen was way beyond what a young man his age could gather together.

Tearfully, he decided to give up his plan to emigrate. Nonetheless, he was unable to cast aside his plan to leave the countryside. In 1903, at the age of 15, Magokichi brought up the matter with his mother Kuni. "I want to go to the city, become an apprentice and save 10,000 yen." His mother, who herself had been an apprentice in Hyogo Prefecture and who regularly grumbled about the inconveniences of country living, understood his feelings and encouraged him. While Chuzaburo was away doing volunteer labor in a temple in Kyoto, she sold a bag of rice for 3 yen 60 sen to make it possible for Magokichi to leave his native home.

At dawn on February 6 of that year, Magokichi put on his dark-blue cotton clothes, shouldered his wicker trunk and headed off, brimming with hope. His destination was Osaka, where his oldest brother Eitaro was working. Each time he looked back over his shoulder, he saw his mother standing in the doorway of their house. She stood there until he was completely out of sight.

## Establishing Yamaoka Gasu Shokai

The Industrial Revolution, which began in Britain in the mid-18th century, spread to the major cities of Japan roughly a century later. When Magokichi arrived in Osaka, it had become an industrial city that was often referred to as "the Manchester of the East." It had all the features of a major city perfectly suited to feeding a young man's ambitions, but he quickly encountered the harsh realities hidden under the glittering surface.

Taking refuge with his brother Eitaro in Sonezaki, Kita-ku, Osaka, Magokichi as a temporary step became an apprentice at a knitting shop in Higashi-Tenma, where from early morning until late night he kept at the hard labor of spinning the spindles of the knitting machines. By the end of the third day, he left. In succession, he tried working at a variety of trades, from soap manufacturing to cotton-fabric wholesaling to production of mounting paper for photographs. But the life of an apprentice did not suit his personality and he could not get used to life in the city. As a result, his physical condition deteriorated.

As he recovered for a while at his brother's house, his condition gradually improved. He began going to the nearby Dojima River to fish, something he had enjoyed since childhood.

The green leaves of the willow trees along the beautiful riverside reminded him of the scenery of his home village and he felt completely at ease. As he lazily dropped his fishing line into the river, he noticed the hurried coming and going of a large group of workers in a nearby shack-like building.

A short time later he struck up a conversation with a few of the people working there and found out they were employees of the Osaka Gas Co., Ltd. and that the building was the operations office. He had no idea what kind of business a gas company did, but from the bustling in and out of the employees, he figured that business must be quite good. Deciding that he would hardly continue forever depending on his brother for food and lodging, Magokichi decided to take a chance and ask the site supervisor for a job. To his great surprise, the supervisor hired him.

So in April 1905, at the age of 17, Magokichi, as the result of a completely coincidental encounter, obtained employment as a pipe installation worker at Osaka Gas.



Industrializing Osaka, around the beginning of the 20th century

At that time, Osaka was rapidly modernizing and the installing of basic infrastructure was proceeding at a rapid pace, with gas piping being laid throughout the city. From the perspective of the company, which was severely hampered by a shortage of labor, Magokichi's application for a job could not have come at a more opportune time. The daily wage was 42 sen and one could work a day and night shift and earn 84 sen.

From October 1905, a half year after he started work, gas was available in every part of the city and the diffusion of gas engines began. Gas engines, unlike steam engines, did not require large amounts of space. Operating such engines was easy, so they were rapidly being installed in various businesses from small factories in town to movie theaters.

Spurred by the need, Magokichi became involved in the installation of such engines. His work gave full play to his inborn diligence and inquiring mind. As he accumulated experience at various work sites, he learned the principles and the construction of engines.

In addition to polishing his technical engineering skills, he also learned the business side. As the number of places to which gas was supplied increased, a shortage of rubber piping developed. When he happened to see a huge quantity of rubber pipe at a trading company where he was doing some installation, he thought it was rather strange, so he asked about it. He was told that everything was being imported from Britain and during shipment the surface of the rubber hose had dried out. The trading company was perplexed over how to dispose of the hose. When Magokichi stretched out the hose, he could see the netlike pattern of small cracks on the surface, but he noticed that the inner surface was not damaged at all, so there would be no problem in using it.

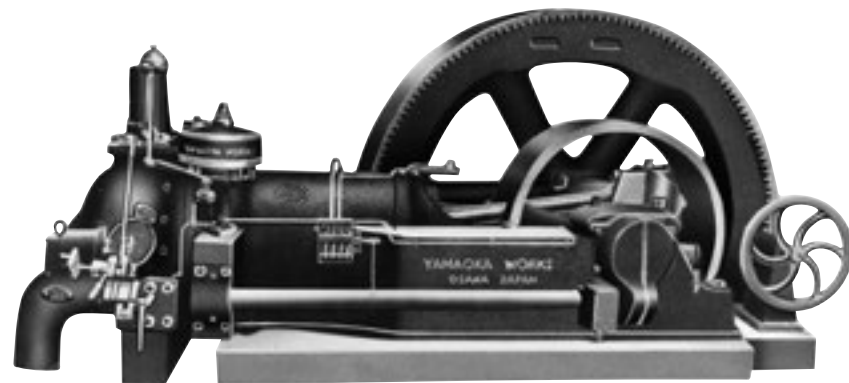

A suction gas engine (40 hp)

It would be wasteful to simply dispose of it, so he offered for a small sum to help the person seeking to get rid of it. Taking into account that Osaka Gas was currently selling rubber piping at about 12 sen per 30.3 cm, he bought the piping for 6 sen and then sold it for 8 sen. It sold like hot cakes. Even when he raised the price to 12 sen, buyers paid without a word of complaint. He felt a certain degree of guilt about selling the pipe to people who were unaware that it was damaged, but in no time at all he made a total profit of more than 7 yen.

It was his first direct experience in the engrossing aspect of business. With this opportunity, Magokichi made a decision. He had promised his mother when he left home that he would save 10,000 yen—a preposterous sum for a regular worker like himself to accumulate. However, if he were to establish his own business, the odds for doing so might not be so ridiculous.

Magokichi quit Osaka Gas, started up his own gas pipe installation and equipment sales business in the summer of 1906. By the end of the year, he had earned a profit of 1,000 yen. With this as seed money, in March of the following year he rented a row house in Tenmawataya-cho, Kita-ku, Osaka; had a telephone installed; and opened a businesses called Yamaoka Gasu Shokai (trans. *Yamaoka Gas Company*). That spring, Magokichi turned 19 years old.

Due to the establishment of one gas company after another and the rapid diffusion of gas engines, there was no shortage of work. In addition to taking on two clerks, he sent for his younger sister Kon from back home and even added his brother Eitaro to the staff.

Work led to more work. The new company would buy gas engines that were left unused at the sites where they did installation work. When they repaired the engine and restored it so that it was as good as new, they created a sensation. The rebuilt engines were much cheaper than brand new engines, and on top of that, the installation was done without charge. That was one reason for their success, but another was that because they obtained the old engines for practically nothing, the profit margin was far greater than in any other kind of work. In the countryside where there was no municipal gas, they sold remodeled suction gas engines with gas generation equipment attached.

Before long, this new enterprise became the core business. By considering what people were looking for and how to make people happy, the company tied new business to the services they offered.



Magokichi at nineteen



Magokichi's keen sense was polished day in and day out in the commercially prosperous city of Osaka, forming the groundwork by which the small, privately-owned shop progressed rapidly toward becoming a manufacturer.

### Founding Yamaoka Hatsudoki Kosakusho, the predecessor of Yanmar

In the process of handling a large number of repairs and renovations of gas engines, the row house in Tenma became too small. In 1912 Magokichi leased a 230 square meters piece of land at present-day 1-32 Chayamachi, Kita-ku, Osaka. He gathered together 5 engine lathes, established a repair shop with an office, and gave it the name Yamaoka Hatsudoki Kosakusho (trans. *Yamaoka Engine Company*). Its first day of business, March 22, is celebrated as the foundation of what would later become the Yanmar we know today.



1921 New Year commemorative photo of Yamaoka Hatsudoki Kosakusho

The company employed another seven or eight factory workers, but Magokichi, covered with oil, continued working as usual while actively leading the way. The company got off to a favorable start, but the wave of modernization brought forth unexpected developments.

In 1913 Ujigawa Denki (trans. *Ujigawa Electric*) constructed a large-scale hydroelectric power plant, providing the Kyoto-Osaka area with electricity. In addition, the company began to sell electric motors. Just as gas-powered engines were finally coming into general use, they were becoming antiquated. Dealers in the buying and selling of gas engines in Osaka unfortunately ended up going out of business one after another.

Magokichi did not sink into low spirits. To the contrary, he simply shook off this apparent setback. Magokichi had twice as much enthusiasm for pursuing knowledge as the next person, but because of his family's circumstances he had been unable to receive sufficient education. Thinking that by adding to his store of knowledge he could make up for his lack of learning, he took advantage of every occasion to travel around and observe.

No information could be more dependable, he thought, than the information he could gather with his own two legs and his own two eyes. Urban areas like Osaka had become supplied with electric power, but Magokichi knew that the countryside was still dependent on gas. Looking at the broad market, he knew that the demand for gas engines and suction gas engines was actually on the increase.

One by one, Magokichi began buying, repairing and renovating the no longer needed gas engines he could find in Osaka. Once they were rebuilt, he traveled from city to city in western Japan and to the textile manufacturing regions of Senshu, Nishiwaki, Tango, Kaga and Enshu selling these engines. The demand was so great that the company was unable to handle all of the repairs and rebuilding. By seeking cooperation from nearby ironworks, he continued his sales visits.

### Wartime boom and postwar recession

World War I broke out in July 1914. The export of war supplies from Japan, far from the main theater of the war in Europe, led to an unprecedented boom. In response to the prosperity of industrial



The Uji power plant of Ujigawa Denki (completed in 1913)

circles, the demand for gas engines increased. Yamaoka Hatsudoki Kosakusho rode this “special procurements boom” and by war’s end reached profits of more than 300,000 yen. It was an enormous sum, equivalent to several hundred million yen today.

However, the favorable circumstances did not continue very long. In November 1918, Germany and the Allies concluded a cease-fire agreement and the result was a sudden reactionary recession, in which orders for gas engines ceased completely.

Magokichi decided to take time off and refresh himself. Until then, he had continued working at a feverish pace, but he had suddenly grown to dislike the business of buying something from one person and then selling it to someone else while making a profit as a go-between.

Looking back, while he felt gratified as an engineer repairing and rebuilding gas engines, as the business grew larger, without fully recognizing it, he had fallen into taking the attitude that any means used in the process of selling something was justified. This had not been his original intention and it was not the kind of work one could devote one’s life to.

The following was a case in point. An engine that Magokichi had sold was crated and on the way from Hakata harbor to Ikinoshima in Nagasaki Prefecture, the ship carrying it encountered stormy seas and sank. With the help of the insurance company, the ship was raised. Magokichi headed to Hakata, ordered new parts, fixed the engine and once again shipped it off to Ikinoshima. On the train going back to Osaka, he suddenly thought to himself, “What have I done? That engine shouldn’t be used anymore. All I was thinking about was that I had sold it!” (Magokichi Yamaoka, *Watashi no Ririkisho*, trans. *My Personal History*). He regretted his thoughtlessness. It saddened him to think that somewhere deep in his heart he had simply taken advantage of another person’s misfortune to make a profit.

Such experiences accumulated and finally, he grew disgruntled with being a broker by trade. This feeling was further strengthened by the low spirits he fell into as a result of the recession that followed the end of the war. By this time, he was already married and had a son named Yasuhito. Magokichi decided to return to his home village, with wife and son, in May 1920.

## Start of a new career as a manufacturer of oil-powered engines

Back in his native place, his father Chuzaburo had already passed away. But his mother Kuni, who had stood in the doorway seeing him off that day long before, was still in good health. Kuni was absolutely delighted at the hero’s welcome given to Magokichi, who was the most successful person in the village. In her expression, Magokichi realized how hardened his own heart had become and he was comforted.

However, having always had his eyes focused on what was happening in the world and managing various kinds of businesses, the tranquil country life eventually became boring.

He had 300,000 yen on hand. The economy had not yet recovered, but even if he were to lose half of what he had gained so far, the desire to do some kind of work came to the fore once more. In August 1920, three months after he had arrived, he headed back to Osaka.

In March of that year, the Japanese economy had been caught up in the great turmoil resulting from the postwar crisis and there were bank runs one after another. All that awaited Magokichi, who returned to Osaka in the midst of this turmoil, was a stock of 30 gas engines stored in the repair factory.

The work that he had anticipated had abruptly stopped and there was not a single phone call from a customer. After days of opening for business and having no business at all, he abandoned the handling of gas engines completely. Just as he was beginning to consider what to do next, a certain person came to mind. The man was Sentaro Okoshi.

Okoshi had been his coworker during his time at Osaka Gas. After that, Okoshi had returned to his native place in Marugame, Kagawa Prefecture, and had operated an ironworks. He had purchased several 3 hp gas engines from Yamaoka Hatsudoki Kosakusho. When Magokichi inquired what he was using the engines for, Okoshi had replied that he converted them to oil engines to power rice hulling machines and sold them to farmers. Curious about what this was all about, Magokichi decided to pay a visit to his friend in Marugame.

“Fix the mill so the underside turns, and it turns by way of a thick hemp rope powered by a rebuilt oil engine. This way, where



five people turning the mill by hand do 300 kg of rice in an hour, the engine-powered huller will do 1800 kg of rice—a six-fold production.” (*Watasbi no Rirekisho*)

Magokichi knew intuitively that he had found something important. He knew immediately how valuable a “powered rice huller” could be.

If one could develop a light-weight, portable, convenient oil-powered engine, it would clearly reduce the heavy labor of the farmer. He made up his mind to produce just such a machine. It would not be the kind of work where he could make a profit without putting out a lot of effort. But he could make something that would benefit others and he could become a manufacturer who could be proud of what he provided.

### Birth of “Yanmar” products

With the objective set, all that remained was to implement it. Upon returning to Osaka, he purchased an imported oil-powered engine used for shearing wool and immediately set to work. The lightness of the engine body would be maintained, and through repeated rebuilding, he gradually developed an engine that would

Yanmar throttle governed oil engine; the first product to be given the name “Yanmar”

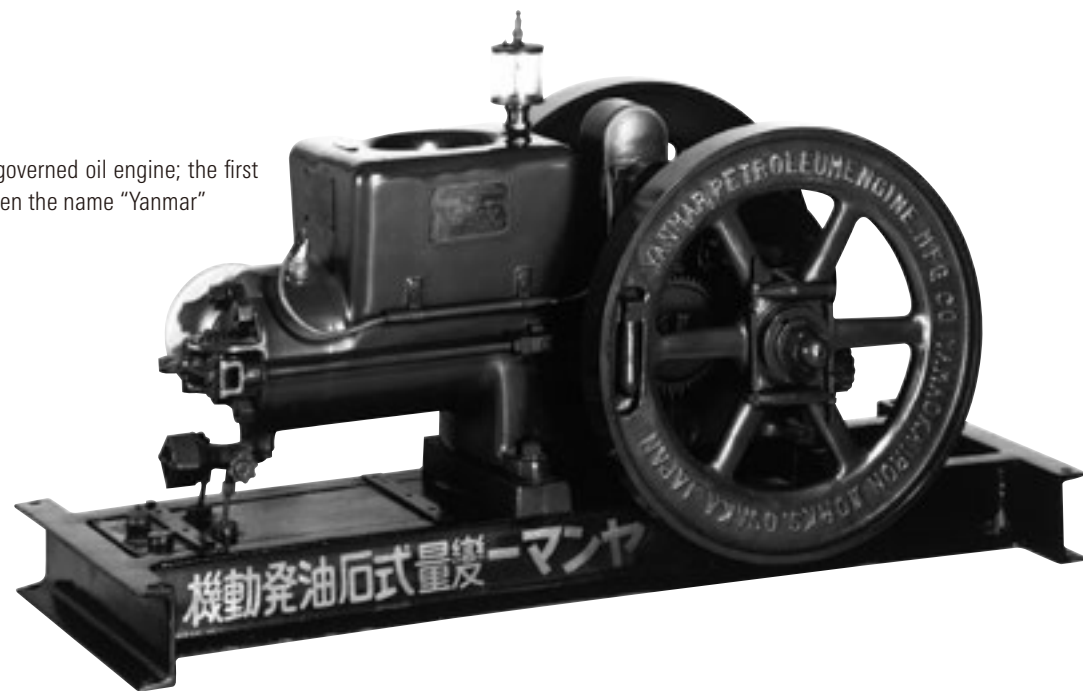

stand up to the hulling process. Three months later, in November 1920, a prototype of an agricultural-use 3 hp vertical oil-powered engine was completed. It was one-fifth the weight of the engine that was used in Marugame, at a light 110 kg. It was both Magokichi’s first monumental product as a manufacturer and also Japan’s first oil-powered engine designed specifically for agricultural use.

In March 1921, he developed a horizontal oil-powered engine and gave it the name “Yanmar throttle governed oil engine.” The “throttle governed” referred to the saving of fuel due to altering the revolution speed by means of a governor, a speed regulator, which at the time was a unique design.

This product was the first to be given the name “Yanmar,” but a number of complications arose before deciding on that trademark.

Magokichi recalled his father Chuzaburo comment, “There are lots of dragonflies (*tombo*) this year, so it’s bound to be a great year for crops.” With this image of an abundant harvest in mind, he considered taking “*tombo*” as the trademark. However, another manufacturer had already registered that name. He was considering purchasing the trademark from the current owner, when one of his employees made a suggestion. “Rather than doing that, how about taking the name ‘*yanma*,’ the species of large dragonflies that are called ‘king’ of all dragonflies?”

“*Yanma*.” The name sounded appealing to Magokichi. He also liked the fact that it was somewhat close to “*Yamaoka*.” To make it easier to say, he decided to extend the final vowel sound so that it became “*yanmaa*” (English transliteration: Yanmar).

### Aiming for the diffusion of engines for agricultural use

While the company had put its original oil-powered engine on the market, at that time there was still no concept of “engine-driven farm work.” To spread the idea, it would be necessary to demonstrate to farmers just how helpful such equipment could be.

Magokichi set to work developing machines that could be connected to oil-powered engines to perform farm labor, and in September 1921, the company put on sale a powered rice huller. He hauled one to his hometown, Higashi-Atsuji and gave a public demonstration to an audience of farmers. Not only was it capable



In Japan, dragonflies symbolize a rich harvest



A local competition using oil engines and powered rice huller (around 1921)

of hulling 1800 kg of rice in a single hour but the hulled rice grains were cleanly processed. Everyone attending was amazed.

Use of the mechanism was offered free of charge throughout the village and a demonstration was also presented to people gathered in front of Nagahama station. On that occasion they charged about 750 g per 60 kg of rice, but there was no end to the people who came to have their rice hulled. In addition to earning a small fee for hulling, the demonstration was great advertisement, killing two birds with one stone. Furthermore, the company put advertisements in the newspapers saying, “If you purchase one of these powered rice hullers for 650 yen and loan it out for a fee, you can make a profit of 1,000 yen during a single autumn.” As a result, orders poured in from all over the country. In fact, orders were so numerous that at one point production could not keep up with the demand.

When the production system finally allowed some leeway, Magokichi loaned out 20 powered rice hullers free of charge to his relatives and let them earn fees from hulling. He wanted to be of some help to his extended family who were so poor that some had to run away under cover of night because they could not repay loans and were enduring difficult times. This was an example of Magokichi’s consideration for others, because he knew all too well the poverty of isolated villages and the harshness of agricultural labor.

Following the powered rice huller, the company developed a “vertical pump” which pumped water up from irrigation canals into paddy fields. This was also sold as a set with a throttle governed oil engine. A major drought occurred throughout the country from 1923 to 1924 and this device had explosive sales. Due to the impact of the 1923 Great Kanto Earthquake, the Japanese economy was unable to sweep away the widespread mood of depression, but during that two-year period Yamaoka Hatsudoki Kosakusho made a profit of 700,000 yen, and was able to use 300,000 of that to purchase state-of-the-art equipment, including imported automatic lathes.

However, Magokichi was not simply pleased with himself as he watched the orders for pumps pour in. The drought was particularly severe in Shiga Prefecture, and with the cooperation of the prefectural agricultural experiment station and the agricultural affairs section, he arranged to have vertical pumps loaned out free of charge to farms in Yasu and Kurita, two counties where many fields were on the brink of destruction. Behind this, too, was Magokichi’s strong attachment to his native place.



A vertical pump in operation

## Successive ordeals in expansion of domestic and overseas business

With its products evoking massive response, far exceeding expectations, Yamaoka Hatsudoki Kosakusho became known across Japan as an oil-powered engine manufacturer. In rapid succession, it put on sale an agricultural-use horizontal “Yanmar throttle governed oil engine” in 1924, and in April of the following year, the “Yanmar offset oil-powered engine.” These two engines, which greatly reduced the characteristic vibration of the oil-powered engine became hit products in no time at all. Also in 1925, aiming at opening new markets, the company put on sale an oil-powered engine for fishing boats: “Yanmar Ford.”

Accompanying the broad penetration of Yamaoka Hatsudoki Kosakusho’s products into the market, some who used these products expressed a desire to be involved in selling them. From among these candidates, Magokichi selected those who had significant skill in the handling and repair of the products and commissioned them to sell the products. This later became the parent body of the special sales agents organization.

Furthermore, in addition to the previously established Tokyo Office, Magokichi opened branch offices in Fukuoka and Hokkaido to respond to the expanding markets there. He even opened a branch overseas in Seoul, Korea, and commenced exports to southern China. The company expanded its foothold overseas by



The Hokkaido branch

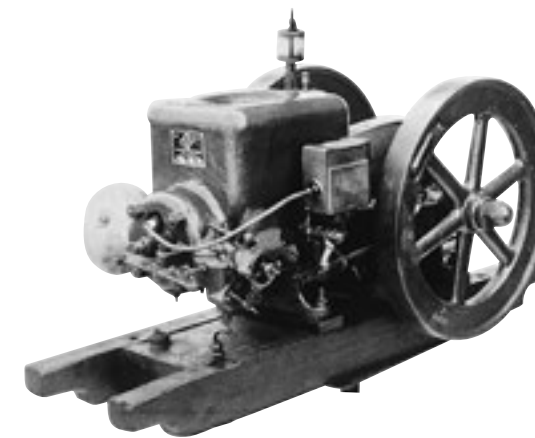

Yanmar offset oil-powered engine (1925)

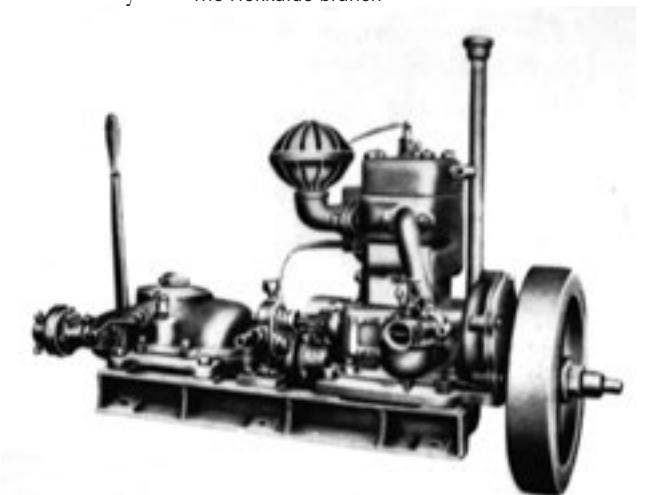

The oil-powered fishing boat engine, “Yanmar Ford” (1925)





Extracting hemp fiber from hemp stalk with the oil-powered engine in Davao, the Philippines

commencing production in the Philippines through a tie-up with a local factory and placing branch offices in Taiwan and Shanghai. In February 1928 he went on an inspection tour of Singapore and the islands of the South Pacific (Micronesia) with the goal of researching the markets there.

Even though Japan was under a recession, Yamaoka Hatsudoki Kosakusho continued making great strides, but things changed dramatically when the Great Depression that occurred in October 1929 was followed the next January by the crisis of the lifting of the gold embargo.

As far as Yamaoka Hatsudoki Kosakusho was concerned, the hardest blow was the agricultural crisis. The price of agricultural products, especially rice and silk cocoons, fell, and to compensate for that, farmers attempted to increase production, which only led to further declines in prices, falling into what is referred to as a “famine because of a bountiful harvest.”

Further blows that would worsen the business slump awaited. First, several accidents occurred. An oil engine at a lumber dealer in Ise exploded and caused a fire. In Wakasa, the crankshaft on a fishing boat engine broke and the boat was unable to return to port. Such misfortunes occurred around the country in succession.

Day after day, Yamaoka Hatsudoki Kosakusho was laying stress on improving its products, but during that period it was impossible to muster sufficient resources and technology, and therefore it was impossible to avoid disparities in quality. In addition to the accidents, other problems occurred because customers mishandled the engines. Whatever the cause, when an accident did occur, someone lost a valuable asset and in some case a person’s life was lost. Magokichi realized once again just how heavy a responsibility a manufacturer bore and began to develop a dread of manufacturing engines.

Another issue was an outbreak of labor disputes. The inception was his placing brother-in-law in charge of the Tokyo Office. Following the 1923 Great Kanto Earthquake, this brother-in-law purchased 15 large trucks to start up a business hauling gravel for construction. But the business failed, resulting in heavy debt. At the hands of a moneylender, the Tokyo Office and even Magokichi’s house in Ashiya were seized. There was also danger that Yamaoka Hatsudoki Kosakusho would have to be mortgaged. As a last-ditch plan, in February 1931, Magokichi reorganized Yamaoka Hatsudoki Kosakusho, which had been under private ownership, as a public



Yamaoka Hatsudoki Kosakusho (in the 1930s)

corporation with a capital of 1 million yen, taking the position of president-director and retaining all of the shares himself.

However, this step triggered a labor dispute. At that time in Osaka, there was a flood of labor movements. One influential leader agitated against the management saying, “The company does not belong solely to Magokichi as an individual. He should give half of his shares to the workers of the company who have contributed to its development to date.” The strike, which started in April 1931, lasted a half-year and reached a monetary settlement of 20,000 yen.

What with the never-ending recession, the succession of accidents and the long-lasting strike, even Magokichi, president of the company, was worn out and had lost virtually all of his enthusiasm for business. He later recalled this period in *Watasbi no Rirekisbo*, “I left matters in the hands of executive managing director Kozo Murakami and the Nomura Bank and escaped to Dalian, Manchuria, to take a break and go fishing.” However, on the occasion of this purported fishing expedition, he did promote cooperation with Fukusho Company, taking measures to expand sales across the whole of Manchuria.

On the reverse side of his feeling disconcerted by repeated hardships and wanting to distance himself from business was a desire to break through the status quo and develop a more energetic enterprise. By now, Magokichi Yamaoka simply could not eliminate business from his life.

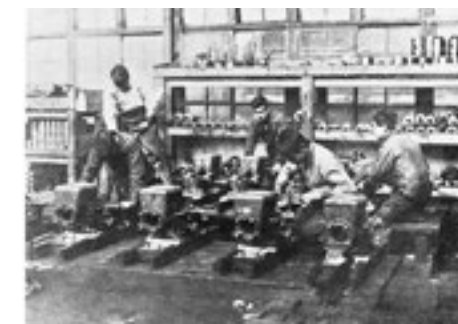

An assembly plant for oil-powered engines

Development of the World's First Small Diesel Engine

---

*1932-1945*

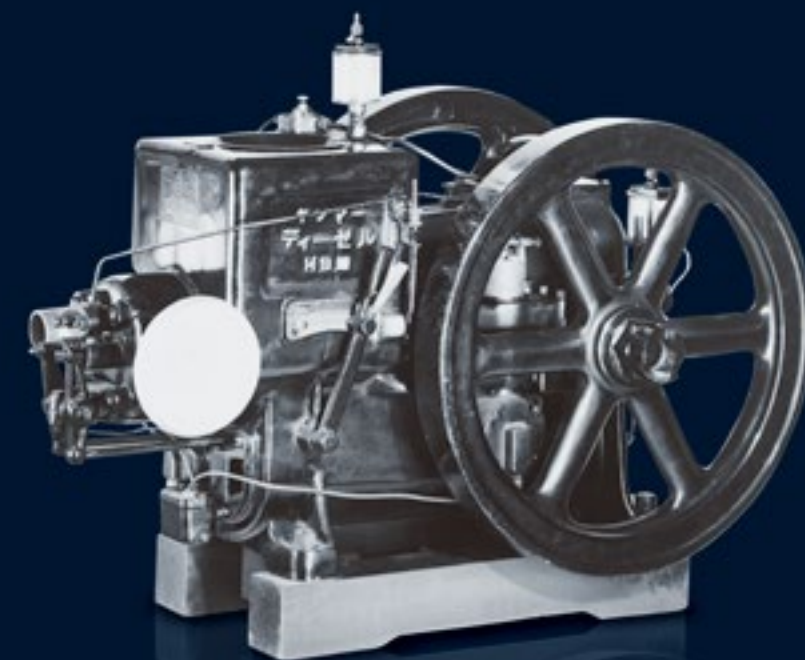

**HISTORICAL BACKGROUND**

The Japanese economy, which had slumped due to the tremendous drop in prices because of the Great Depression and the lifting of the gold embargo, made a recovery with the aid of the positive fiscal policy and easy money policy instigated by Minister of Finance Korekiyo Takahashi. However, taking the opportunity of the February 26 Incident, in which Takahashi was assassinated, in the name of national defense the military began full-scale political intervention, setting out political policies that placed priority on demand in the military sector.

With the opening of hostilities in the Second Sino-Japanese War in July 1937, strict government controls over industry were implemented. In September the so-called “three control laws,” including the Munitions Industries Mobilization Law, became effective. In April 1938 the National Mobilization Law was promulgated. Following this, the Imperial Rule Assistance Association and the Greater Japan Industrial Patriotic Association were founded. In every aspect of the citizens’ lives, control was reinforced and businesses were prohibited from free economic activities.

In December 1941 the country plunged into the Pacific War. At the beginning, the war went in Japan’s favor. By mid-1942, however, because of the growing shortage of materials resulting from the expansion of the war front and prolongation of the fighting, the situation reversed. The government designated certain private enterprises as munitions companies and directed them to produce necessary goods, but the situation worsened steadily and on August 15, 1945, the war came to an end. At the close of the war, the land had been laid waste and the industrial infrastructure had experienced devastating damage.

**Revelation at the Leipzig Trade Fair**

After returning from his fishing expedition in Manchuria, President Yamaoka had still not retrieved his zeal for business activities, and he was spending more of his time fishing off the Akashi coast.

One day his fishing companion started boasting about the things he had observed during a recent visit to Europe and North America. ‘Rather than wasting time on things that aren’t interesting,’ he thought to himself, ‘it would be better to go and spend some time in America or Europe. I’ve got time, so why not take advantage of the chance to go?’ (Magokichi Yamaoka, *Watashi no Rirekisho*, trans. *My Personal History*).

Of course it was not as easy to travel to the West in those days as it is today. But President Yamaoka, who until then had always gathered information and discovered trends in the world around him with his own eyes and legs, felt a real fascination with the idea of going to foreign countries that he had never visited.

As with his earlier travels to Manchuria, the primary objective was simply diversion, but his interest was particularly aroused by the mention of a major trade fair in Leipzig, Germany, and he remembered to include that in his itinerary. In the back of his mind, he embraced a faint expectation: ‘I might just find a hint for some new kind of business.’ (*Watashi no Rirekisho*)

On February 11, 1932, President Yamaoka, together with a young employee who could speak English a little departed from Osaka. By way of the Trans-Siberian Railway, it took them more than 20 days to reach Germany. While this might sound like a slow way to travel, in those days the Siberian rail route was actually the fastest way to reach Europe.

On the morning of March 3, they reached Berlin, shortly before the trade show opened in Leipzig.

Every part of Europe was suffering from the damage caused by the Great Depression, and yet the international trade show, which could boast a history of more than 700 years and was said to be the world’s largest, was a roaring success with more than 200,000 people attending from around the world.

Among the many exhibits, President Yamaoka naturally headed to the engine hall. There he watched a promotional film for *Maschinenfabrik Augsburg-Nürnberg A.G. (MAN)*, manufacturer of the



The Leipzig trade fair (around 1932)



world's first diesel engine.

This film explained in easy terms the structure and the manufacturing process of the diesel engine and illustrated the qualities that made it superior to the oil engine. It was safe, without the danger of igniting fuel due to an operational error, and it was highly durable. What entranced him more than anything else was its great fuel efficiency. For low-quality oil was available, the cost of fuel was approximately one-fourth that of oil engines.

President Yamaoka had not been oblivious to this performance. He first encountered the diesel engine in March 1929 at an engine exhibition in Tennoji, Osaka. He knew intuitively that such an engine would be ideal for agricultural use. However, all of the engines at the exhibit were large, and it would be necessary to downsize them considerably if they were to be used in agriculture.

He dispatched young engineers to the exhibition to observe every individual detail, including nozzles and pumps. Further, under the supervision of the dean of the Faculty of Engineering of Kyoto University, he completed construction of a vertical 2-cycle 5 hp (6 hp at completion) engine. However, due to the long-lasting recession and labor strikes, he discontinued further development. Other companies might have attempted to reduce the size of the engines, but it was technically difficult to reduce the size and the horsepower, so no such products had yet been brought to market.

Still he could not keep from wondering whether making such an engine was really beyond the realm of possibility. Would it not be possible to make a 3–5 hp diesel engine with the same favorable performance of the large-scale engines? He had come on the trip for diversion, but before he was aware of it, he became completely absorbed in such speculations. Day after day, he showed up at the engine hall exhibit taking in every detail possible.

The German scientist Dr. Rudolf Diesel conceived the principle of the diesel engine and patented it in 1892 and completed the first model in 1896. It was first imported to Japan in 1907 and in 1916 Japan's first domestically produced 250 hp engine appeared.

Encountering the diesel once again in Germany, President Yamaoka understood even more deeply the principles of its operation and the process of its production and admired its efficient performance even more. The intuition he had had at Tennoji was transformed into a firm belief. He had no doubt that there was no better power source for reducing harsh farm labor.

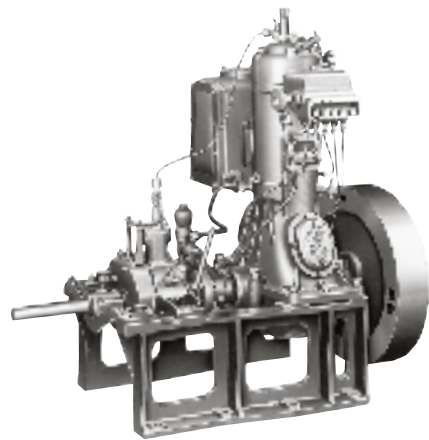

The first Yanmar diesel engine

“This is the engine of the future.”

The future course of action of the company as a diesel engine manufacturer was decided by what he saw in the short promotional film.

The problem was how to reduce the size. President Yamaoka constantly said, “In the countryside, a big engine is unnecessary. A small 3–5 hp engine is sufficient.” (*Shin Yamaoka Magokichi-den: Watasbi wa ikite iru*, trans. *Living My Life*) Assuming that there had to be a factory making such small engines in the country where the diesel was created, he searched 20 or 30 factories trying to find such a manufacturer. Wherever he went, however, the answer was always the same. There wasn't a single place attempting to produce such small engines.

This caused the faint flame that he had kept burning in his heart to burst into a large one. In that case, he thought, ‘I'll make one.’

It seemed absurd that he had once considered withdrawing from business altogether. His mind became completely absorbed in the development of a small diesel. First of all, it was imperative to learn the latest engine technology in Germany, the most advanced country for diesels, and then he had to utilize it in development. Before leaving Germany, he commissioned the Motorenfabrik Anton Schlüter München Werk company in Munich to research and manufacture two prototype 5 hp engines and commissioned the Friedrich Deckel A.G. company to build a prototype fuel-injection pump, a valuable component.

Faced with a new challenge and enterprise, he felt an upsurge of emotion he had not experienced for a long time. After spending three months in Britain, France and other parts of Europe, he stopped briefly in America and Hawaii and returned to Japan in July 1932.

### After a bitter struggle, the jubilation at a “World's First”

President Yamaoka had made tours of inspection of the major state-of-the-art factories of Europe. In comparison with those facilities, when he looked at his own factory for the first time in months, it seemed forlorn and miserable. Would it really be possible to develop a small diesel engine—a type that no one else in the entire world



Dr. Rudolf Diesel



had been able to create? Upon returning to Osaka, such doubts flitted through his mind, but he decided that the only way to achieve his goal of reducing the heavy labor of the farmers via a safe economical power source was to simply attack the problem.

The ultimate development objective was to build an agricultural-use, portable 3 hp diesel engine. Given the economic circumstances of small farmers, it was all-important that the engine use cheaper heavy oil as fuel. President Yamaoka himself actively led the development team composed of three young engineers. They began designing and experimenting with prototypes based on the latest knowledge they could gain from the fuel injection pump that was produced by Deckel and the diesel engines he had purchased in Germany.

A diesel is an internal combustion engine which compresses air inside a cylinder and heats it so that the atomized fuel inside combusts spontaneously. For both large-size and small-size engines, the principle should be identical, but because the combustion conditions differ, simply reducing the scale of the engine is insufficient.

Even in terms of the combustion chamber, there was a difference in conditions between the small and large engines. If you attached a pre-combustion chamber to raise combustion efficiency, you needed to consider several dozen ways of combining the capacity with the main combustion chamber. There were innumerable issues like this and the only way to proceed was to solve them one by one. Leading engineers around the world had tackled these troublesome features and found them insurmountable.

Beginning in July 1932, they toiled night and day, immersed in development, but made very little headway. Toward the end of September, they finally rejoiced at completing a 4-cycle 3 hp prototype diesel, but when they started it up, huge clouds of black smoke poured out, turning everything around it black. The development team stayed in the factory day and night trying to make improvements, but they were unable to solve the problem. After repeated urging, the Schluter company in Germany finally shipped the prototype they had commissioned, but it proved of little use in subsequent development. At the end of the year, as a means of supporting the engineering staff, they took on engineers from outside with experience in dealing with large-scale diesels. Despite this assistance, by the end of the following spring, there were still no signs of future progress.

#### Firing order in diesel engines

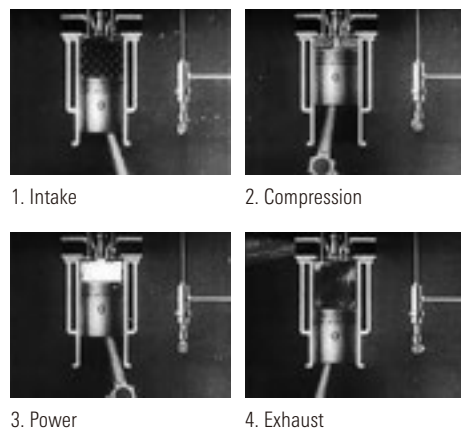

Source: *Watashi wa Ikite iru*

In contrast with the snags that were impeding development of small engines, the mid-size diesels had reached a technical level that allowed them to be put on the market.

In January 1933, they completed prototypes of the vertical 2-cycle DH model (1 cylinder, 25 hp), followed by the 2-cylinder DJ model (50 hp) and the 3-cylinder DK model (75 hp). In June of that year, they began production of the vertical 4-cycle DD model (10–12 hp), expanding their line up one at a time.

Even then, President Yamaoka did not set aside his desire to produce a small engine. The second summer rolled around but he remained undiscouraged and spurred his engineering group to press onward. To the new company employees he earnestly advocated the social benefits that would result from the creation of a small diesel engine. However, they could not continue pouring money into research with no end in sight no matter how enthusiastic they were. In due course, the bank with which they had an account became reluctant to extend further loans.

Even President Yamaoka began to lose resolve. He had exerted himself to the fullest in an effort to develop such an engine with his own hands, but as an entrepreneur he began to wonder whether he might be making a fatal mistake. Was he just putting the company into debt and exhausting his employees to no avail?

By late September he finally decided to suspend development. He gathered his engineers together and made an announcement.

“For more than a year, we have made great efforts over and over again, but prospects are dim. I was wrong to think that a nobody like me could somehow build the first small diesel engine in the world. For the present, I’m giving up on the diesel. I’m giving each of you 200 yen. I hope that you will use it to go to the hot springs at Arima or Shirahama and recover from your summer fatigue.” (*Watashi no Rirekisho*)

However, not a single member of the group headed for a hot spring. To the contrary, the engineers in the company dedicated even more energy to reconsidering the designs and grappling with the prototypes. Seeing this, President Yamaoka changed his mind and once again began to devote himself to research.

Morning came on December 23. When President Yamaoka arrived at work, his engineers, eyes blood-shot from working through the night, rushed up to him.

“The engine is working!”

“It’s running!”

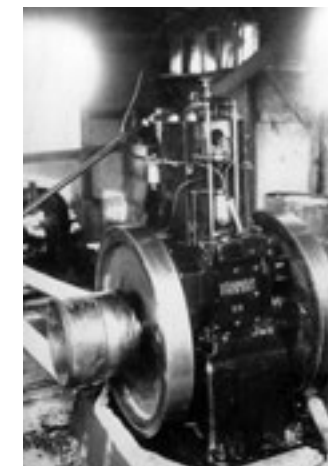

The vertical 4-cycle DD model (1933)

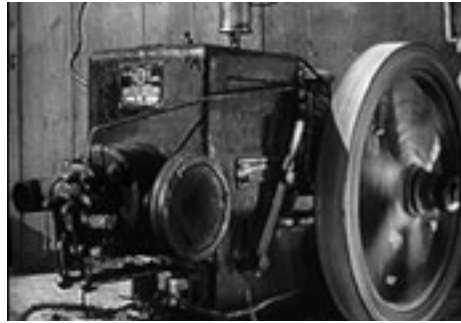

The prototype of the HB model

Source: *Watashi wa Ikite iru.*

Running to the workshop at the rear of the office, he saw the prototype small-size diesel engine running smoothly. The black smoke, which had been the toughest problem, was gone. The engine was designed for an output of 3 hp, but with a load the output reached 5 hp.

It worked. Confident that they would be successful, President Yamaoka called the contact person at his bank to tell him the news. In no time at all, the bank sent a congratulatory cask of sake wrapped in a rush mat to celebrate their success.

He called to his engineers in the workshop to come and enjoy a toast of sake together, but they didn't respond to his calling. When he went to the workshop to see what was going on, he found them gathered around the engine with handkerchiefs pressed to their eyes. These men, who had overcome numerous failures and enormous pressure and finally reached the day they had dreamed about, were unable to suppress the emotions that welled up from deep inside. Their shoulders shook as they shed tears of gratitude. Seeing this, President Yamaoka recalled the 17 months of hard struggles.



HB model, the world's first commercially viable small diesel engine

Self-confidence and faintheartedness were two sides of the same coin. But they had finally accomplished something that no one else in the world had done. Before he realized it, tears were streaming down his cheeks as well.

Just then, he heard the sound of a bell ringing along the main street nearby. It was the bell of a newspaper seller passing out an extra edition announcing the birth of the Emperor's first son, Crown Prince Akihito (the current Emperor). Deeply moved, President Yamaoka proclaimed, "Yanmar's small diesel has been born on the same day as the Crown Prince. This is an auspicious sign that we will always remember." (*Watashi no Rirekisho*) The company later established this day as Diesel Commemoration Day.

The completed engine was named the HB model. It was later nicknamed "*yokosui*," which became the byword for small diesels and was taken from "*yokogata suirei*" ("horizontal and water-cooled"), the company's first of that type.

## Overcoming financial issues to build the Kanzaki Plant

The reason President Yamaoka had been so persistent regarding the small diesels was that he was confident in their potential. What was true for impoverished farming villages was true in any field. For fuel-poor Japan, a fuel-efficient engine was essential. It was clear that in the near future, the diesel would surpass the oil engine as the principal type. In considering future development, it would be difficult for Yamaoka Hatsudoki Kosakusho (trans. *Yamaoka Engine Company*) to manage alone. It was necessary to set up a comprehensive production system promptly.

In no time, President Yamaoka went into action to build a large-scale factory. He set about acquiring a construction site at the beginning of 1934, immediately after the birth of the HB model. It was a lightning-fast feat.

Actually, in 1932 after returning from the Leipzig trade fair, he had begun planning a factory specifically for producing small diesel engines and had stuck on the wall of this office a forecast drawing of a three-story ferro-concrete factory. This dream of creating a factory to produce an engine that no one in the world had ever seen was, he assumed, within the realm of possibility.



The design of the Kanzaki Plant

In January 1935, the company purchased a site of approximately 40,000 square meters at present-day Nagasu-higashidori 1-1-1, Amagasaki, Hyogo Prefecture, and construction of the new factory began. This location was selected because transportation near Osaka was convenient, it had advertising effectiveness because it was near the train lines near the former JNR Kanzaki Station (present-day JR Amagasaki Station) and in the future it would be possible to expand.

At the same time, in order to ship to markets a high-performance small-type diesel engine, the company established an integrated production system for related parts, including fuel-injection pumps and, beginning at the end of 1934, had been building these parts factories in the Osaka area one after another.

To all intents and purposes, it appeared that the small-diesel enterprise was off to a favorable start, but an ordeal, which President Yamaoka would recall as “the biggest crisis of my life,” awaited him. (*Watashi no Rirekisho*)

Doubts arose over whether he could raise the 1.2 million yen necessary to build the factory. He applied for financing at a number of banks but was turned down by all of them. If this major project, upon which the fate of the company rested, were to fail, all of their hard work to date would come to nothing.

Construction had already begun and approximately 600 workers had been newly hired. If they could not obtain financing, then immediately cash flow would become an issue. Relying on connections, he threw himself at the mercy of several different banks, but the results were always the same.

Just as the company was on the brink of being passed into other hands—together with the just-completed small diesel engine—a certain banker introduced him to Tadao Sasayama, manager of the Kobe Branch of the Industrial Bank of Japan.

In May 1935, President Yamaoka called on the branch manager and explained the course of events that had led to the present situation. After explaining the value of the small diesel engine, he made an earnest appeal. “I would like to ask your support for this project from a national point of view.” The company was in financially strained circumstances, but once he launched into discussing the diesel engine, nothing could stop him. Despite the fact that it was the first time they had met, his passionate plea continued for four hours.

Although the branch manager listened intently from start to finish, at the end, he replied, “What you have said sounds too good to be true.” With that, he stood up and walked out. However, the next day he sent several bank personnel to the new factory and had them carry out a detailed investigation.

Another ten days or so passed and the bank called President Yamaoka and asked him to come to the bank. “We’ve learned that everything you explained is true. Before any other bank comes along, we are prepared, for the time being, to provide 1.2 million yen in financing. And should you need it, we are prepared to advance funding of 3 million or even 5 million yen, so please work as hard as possible and expand your business.” (*Watashi no Rirekisho*) The manager wrote a check on the spot. The new factory was safe and it was possible to press forward with construction.

As a result, on January 9, 1936, the new factory, named the Kanzaki Plant, commenced operations. It is now called the Amagasaki Plant. On January 28, Yamaoka Nainenki Kabushikigaisha (trans. *Yamaoka Internal Combustion Engines Co., Ltd.*) was established with the Kanzaki Plant as its main production site.

President Yamaoka was sincerely grateful to Branch Manager Sasayama. Thanks to a single banker with prescience and decisiveness, he was not only saved from the biggest crisis of his lifetime but he was allowed to become a full-fledged entrepreneur.

The first Yamaoka Nainenki Kabushikigaisha produced at the Kanzaki Plant was the S model diesel engine, which was an even smaller version of the HB model. The “S” was taken from “small” and the lineup of engines with less than 10 hp consisted of four sizes



Start of operations at the die-cast plant



Commemorating the completion of the die-cast plant (1936)



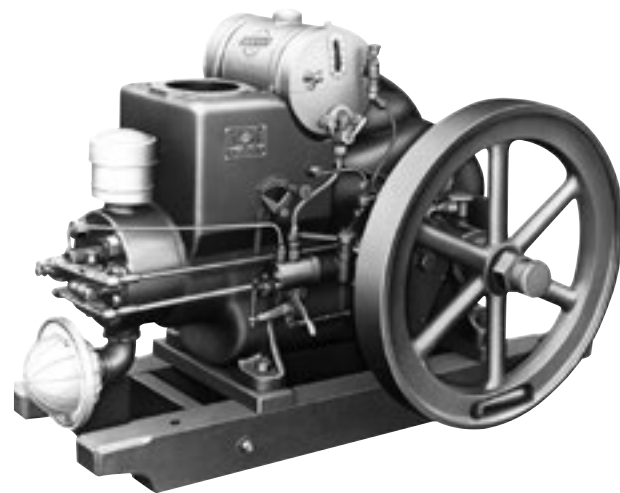

The S model engine

name of model	trial manufacture changes	S1.5	S2	S3	S3.5	S4	S4.5	S5
hp		1.5	2	3	3.5	4	4.5	5
number of revolutions per minute		850	800	800	800	750	750	700
diameter of cylinder (mm)		70	75	85	90	95	100	105
progression (mm)		110	120	130	140	150	160	170
weight		120	153	190	198	250	263	360
manufacturing date		1937.3	1936	1936	1936.11	1936.1	1937.3	1936

Specifications of the S model engine

between 2 hp and 5 hp, added to 3.5 hp and 1.5 hp engines. In 1937, a simple clutch was installed in the 3.5 hp engine making it the first engine for fishing boats.

This S model diesel engine transformed the company from an oil engine manufacturer into a diesel engine manufacturer.

### Arbitrarily deciding to specialize in diesels

When the issue of the Kanzaki Plant construction arose, President Yamaoka was not spending all of his time dealing with procuring capital. While he was working hard trying to obtain funding, he was also working energetically at promoting diesel engines.

In January 1935, he appealed to 11 prominent agents in Shiga Prefecture to implement a sales strategy of the H model series labeled the Crown Prince Birth Commemoration Grand Prize Sale. In light of the fact that diesel engines were still not widely known, the company carried out demonstrations with the cooperation of agricultural organizations, visited agricultural and technical schools and carried out other activities to promote understanding aimed at the younger generation.

In order to directly communicate the superiority of the diesel engine, the company held lectures all around the country. It asked a professor from Kyoto University to explain the technology and then President Yamaoka would take the platform, and before the

audience realized it, they would fall under the spell of his eloquence.

President Yamaoka's storytelling art was unique as well as extremely skilled. In the documentary film *Watasbi wa ikite iru* (trans. *Living My Life*), produced by Yanmar's publicity department, there is a segment from one of his speeches.

“At the time when Dr. Diesel invented the diesel engine, it sucked in air...in an atmospheric pressure of 50 and with a pump it turned heavy oil into spray at a pressure of 350. This blew the oil in with a smack and it burned with a shiver. All of the fuel burned. It fired up 3.5 hp, 3.5 hp, 3.5 hp. A full 3.5 hp sending that piston one way and then back the other. But the other oil engine was putting out 3.5 hp at first, but then? Zero, zero, zero—absolutely nothing!”

Regarding the mechanics, fuel efficiency and safety of the diesel engine, which was leading-edge technology at that time, he would energetically and freely employ simple language and sound effects to get his message across. So that his audience would not get bored, occasionally he would intersperse stories of his failures within his speeches. This way he would stir up the attendees, grab their hearts and increase the fans of Yanmar.

Several things drove President Yamaoka during this period when he was immersed in work every spare moment. One was his aspiration as an entrepreneur to achieve even larger success. But more than that, his desire as an engineer was to extract as much of the hidden, unlimited potential of the diesel engine as he could. Further, he was brimming with hope that through that technology he would be of service to Japan and to the people of his native place.

In November 1936, President Yamaoka gathered representatives of the roughly 600 agents across the nation in his hometown, Takatsuki-cho, Ika-gun, Shiga Prefecture. President Yamaoka held lectures on the diesel engine and they discussed the promotion of the S diesel engine series. This national agents meeting became the forerunner of the Yanmar National Agricultural Machinery Distributor and Dealer Meeting. This was the first step forward in the dieselization of the country.

“National dieselization” meant diffusing the diesel engine throughout the country as the engine of a new epoch replacing the oil engine. Supported by an economic recovery in farming villages, there was a rapid increase in demand for the S diesel engine series. Monthly production goals for the 5 hp or less engines reached 500 units.



President Yamaoka giving a lecture at Okoshi engineering school (1935)





President Yamaoka at a national agents meeting in Takatsuki-cho, Nagahama, Shiga Prefecture (1936)



Agents observing a demonstration of a rice huller with an S diesel engine (1936)

The timing was right. He had made up his mind.

On the first day of the national branch office managers' meetings in January 1937, President Yamaoka made the following pronouncement.

“From this day forward, our company will make its name as a manufacturer specializing in diesel engines. As a consequence, we will cease production of oil engines.”

Those present were left speechless by the sudden “proclamation of exclusive engagement in diesel engines.” While expectations of diesel engines were rising, a deep-rooted demand for oil engines remained, supporting production of 700 to 800 engines a month. President Yamaoka's order was extreme because it meant disre-

garding this demand as well as scrapping everything related to oil engines, from works in progress to materials and wooden mockups. If they were unable to supply these products, there was danger that they would lose the many Yanmar fans they had painstakingly cultivated. It was only natural that some participants felt that this decision went beyond the impossible to ‘totally unreasonable.’

Following that event, President Yamaoka gathered together the agents under the jurisdiction of the head office in Osaka and issued instructions to implement the diesel engine sales strategy. In addition to his arbitrarily deciding not to listen to opposing opinions, some participants expressed their uneasiness about the stock of diesel engines that was backing up in the warehouses of the Kanzaki Plant.



Red dots showing 233 locations in the Kohoku area using the S model engine (1937)

Their fear and uneasiness, however, proved groundless. When February came, the company was deluged with orders for the S diesel engine. By the end of the month, they had a backlog of orders for more than 700 engines. Furthermore, in the autumn of 1937, when they put on a special sale, which included a free drum can of heavy oil with each S diesel engine, there was a large response which further boosted diffusion.

The hasty conversion from oil engines to diesel engines may at a glance have only been possible as a result of President Yamaoka's decision. No one else fully understood the potential of small diesels and no one else understood the circumstances of consumers throughout the country as well as he did.

### Taking "To conserve fuel is to serve mankind" as a fundamental principle

Following the Manchurian Incident in September 1931, the militarization of Japan progressed rapidly, and in 1936 junior army officers attempted a coup d'etat known as the February 26 Incident. Further, in July 1937, in the outskirts of Peking the Marco Polo Bridge Incident occurred, expanding the Second Sino-Japanese War.

In this year, President Yamaoka adopted the slogan "To conserve fuel is to serve the nation" as a fundamental concept in conducting business. During that period, the National Spiritual Mobilization Movement was rolled out as a measure to boost the morale of the citizenry, and from the Patriotic Industrial Service to Patriotic Literature, there was a plethora of slogans with the element of "service to the nation" attached.

What kind of meaning did "repaying the nation through fuel" include? In a trade newspaper in early spring 1936, President Yamaoka wrote the following.

"At present, some 300,000 oil engines are in use in our country, and the cost of the fuel they use has not dropped below 25 million yen. If all of those engines were replaced with diesel engines, the cost of fuel would be reduced to 3.5 million yen. That would mean an actual savings of more than 20 million yen. From a national point of view, one should advocate the dieselization of agricultural engines as soon as possible." (*Shin Nogyo* Special Early Spring Edition, 1936)



The slogan "To conserve fuel is to serve the nation"

What is being referred to here is a call for economizing on fuel on a national scale through dieselization, but, needless to say, underlying this is the primary conviction that it would reduce the burden on impoverished farmers. In its global businesses, Yanmar has extended this basic concept to a much larger scale of "To conserve fuel is to serve mankind" and this concept remains even today an important part of the company's business principles.

In the same year that President Yamaoka promoted the goal of "To conserve fuel is to serve mankind," the "three control laws," including the Munitions Industries Mobilization Law, were enacted. As a result of this, the state was able to mobilize private-enterprise factories for munitions manufacturing. The Kanzaki Plant was ordered by the army to produce several thousand 10 hp diesel engines and the Osaka Plant was ordered to produce 60 hp high-speed diesel engines. The company was also ordered by the navy to produce converted DM engines and diesel power generators. Gradually the company's production was subsumed under the system of munitions production. Further, the company was eventually prohibited from manufacturing S models for civilian use due to restrictions on resources.

Orders for goods from the military continued to grow, and when the factory was designated as a "regulated factory" by the army and the navy in 1939, it became virtually impossible to support production for civilian demands. When the production system became centralized in November 1940, Yamaoka Nainenki Kabushikigaisha absorbed Yamaoka Hatsudoki Kosakusho.

With the start of the Pacific War on December 8, 1941, the company came under even more pressure to produce munitions. In October 1942, the company purchased a 22,407 square meter site in Nagahama-cho, Shiga Prefecture, which became the Nagahama Plant. Originally the facility had been a textile mill which had suspended operations. Lathes and other machine tools were relocated there from the Kanzaki and Osaka plants and were used to produce parts for aircraft.

In April 1943, the company's home office was transferred from Amagasaki, Hyogo Prefecture, to the place where the company was founded: 62 Chayamachi, Kita-ku, Osaka. The Kanzaki Plant was renamed the Amagasaki Plant.

At the very beginning of the war, the Japanese military continued its unstoppable advance, but following the defeat in the naval





The urban area of Osaka in 1945 reduced to ashes in air raids

Battle of Midway in June 1942, the war situation entered a steady downward spiral. By 1944 the American aircrafts began air raids on the Japanese mainland, and in December of that year the company set up a structure to house heavy machinery in the precincts of Kyuan-ji Temple in Ikeda, Osaka, and removed all the machinery and equipment from the Osaka Plant to the new location.

In 1945, B-29 bombers were continuing air raids on urban areas and on May 25 the Tokyo Office was completely destroyed by fire resulting from one such raid. In June the area from the urban district of Osaka to eastern Kobe, Ashiya and Nishinomiya suffered serious damage. The company lost 70% of its structures at the Osaka Plant and the Amagasaki Plant. The machinery and equipment that had been removed from the Osaka Plant escaped danger, but some 30% of the machinery and equipment at the Amagasaki Plant suffered damage. Only the Nagahama Plant survived to the end of the war without damage from air raids.

On August 15, 1945, the Second World War came to an end with Japan's unconditional surrender. Wherever one looked, the neighborhoods of Osaka were burnt ruins. All of the property that had been created with grit and persistence had all too quickly been snatched away by war.

If something has been lost, you only have to make it again. As he watched the flow of people going back and forth through the burnt-out ruins, President Yamaoka directed his own gaze toward what the future era would bring.

## A Life Dedicated to Spreading the Diesel

# 1945-1963

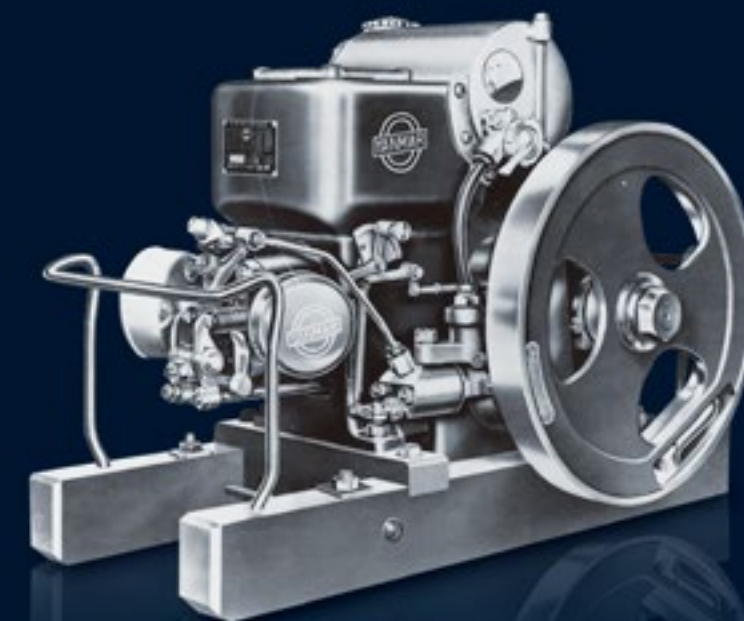

**HISTORICAL BACKGROUND**

On August 15, 1945, as Japan faced the end of the war, it was placed under occupation by the Supreme Commander for the Allied Powers (SCAP) that was referred to in Japan as GHQ (General Headquarters). In order to eliminate Japanese militarism and promote democratization, GHQ enforced reforms that dissolved *zaibatsu* conglomerates, restructured agricultural lands and enacted a new constitution.

Due to wartime damage, the land lay in marked devastation and the economy received a catastrophic blow. In 1946, production in the mining and manufacturing industries was a mere 30% of prewar levels and agricultural production had fallen to about 60%.

Ironically, it was another war that brought about a recovery of the economy which had declined due to war. The Korean War, which broke out in June 1950, stimulated special procurements. As the base of supplies for the American military, Japan assumed responsibility for providing war materials and repairing various types of equipment. By 1952, per capita income in Japan had returned to prewar levels.

Following the termination of the Korean War, the economy went up and down, but the so-called “Jinmu boom,” the greatest period of economic prosperity that Japan had ever known, started in November 1954, and the so-called “Iwato boom” commenced in June 1958, continuing a 42-month economic boom until 1961. A consumer boom ensued, centered around the “three sacred regalia” of home appliances—the electric washing machine, the television and the refrigerator—and with this, industry made rapid advances.

The *Annual Report on the Japanese Economy and Public Finance* that the Japanese government issued in July 1956 noted “the postwar period has come to an end,” and in December 1960 the Cabinet of Prime Minister Hayato Ikeda approved the “National Income-Doubling Plan.” Having emerged from the postwar reconstruction period, the Japanese economy accomplished an unprecedented period of high growth.

**Recovery from wartime damage without delay**

In Osaka, which had been completely reduced to scorched earth, President Yamaoka, who was determined to rebuild the business, took quick action. Ten days after the end of the war, *The Asahi Shimbun* carried an advertisement declaring that the company was resuming operations and the president was getting down to equipping the head office in Osaka and the factories.

The diesel engine manufacturing equipment for the Osaka Plant which had been relocated to Kyuan-ji was moved to the Nagahama Plant, the only factory which had escaped damage during the war. The structure that had housed machinery at Kyuan-ji was dismantled and was used as building material for the reconstruction of the head office building that had been destroyed by fire. Construction of a makeshift building was also begun at the Amagasaki Plant.

The head office building was completed on September 27, 1945. Employees who had been demobilized saw the newspaper announcement and returned to work in rapid succession, and in October the Nagahama Plant began producing the S diesel engine. During the postwar chaos, to accomplish this in two months was a lightning-fast achievement.

President Yamaoka described his frame of mind at that time in the following words.

“I picked myself up to rebuild the business without delay. I was already close to 60 and was at a complete loss for what to do besides make engines, so no matter what the future might bring, in order to go on living, I knew that I had to reopen the business as soon as possible.” (Magokichi Yamaoka, *Watasbi no Rirekisho*, trans. *My Personal History*)

While it was a fact that there was no other course of action available other than to reopen the business, deep in his heart he had a conviction. He saw that the fields in which diesel engines could play a part would expand widely as a power source facilitating an increase in food production in the farming and fishing villages and as an auxiliary power source to compensate for insufficient electric power. In fact, as a result of the ending of the war, because the navy could no longer purchase them, engines that produced electric power were being purchased one after another by factories, banks and stores that were troubled by power stoppages.



Nagahama Plant (around 1953)





A GHQ major giving instructions at the Nagahama Plant



Facilities at the Kanzaki Plant (1947)

The company took the first step in postwar operations by switching from military demand to civilian demand but within a year, it ran into a major issue. As compensation to the victor nations, the Nagahama Plant and the Kanzaki Plant were earmarked for reparations and were to be placed under jurisdiction of GHQ.

A factory to be designated for reparations meant that the business was immediately banned from carrying out enterprise activities on its own accord. If both factories, which after the war had been outfitted with great effort, ended up in that category, there would be no way whatsoever to rebuild the company.

“The small diesel engine is absolutely essential to the urgent current business of increasing food production in farming and fishing villages. While work on the diesel engine was initiated as a means of reducing the labor of farming, mountain and fishing villages, it was put to use by the military during the war, but it is now a champion of peacetime industry. Being designated for reparations is an entirely unexpected event.” (*Shin Yamaoka Magokichi-den: Watashi wa ikite iru*, trans. *Living My Life*)

Despite the fact that GHQ had absolute authority in such matters, this was something that President Yamaoka could not take lying down. He made frequent visits to GHQ and was persistent in his appeals. His desperate resolve must have communicated itself because in the end the reparations designation was removed.

In January 1947 the first step of equipping the Kanzaki Plant was completed and the production system was based on that factory and the one at Nagahama. Having said that, amidst the extreme material shortage of the postwar period, it was not possible to keep up with the increasing demand. Insufficient capacity continued to be a serious obstacle.

Accordingly, in May, Kanzaki Kokyukoki Mfg. Co., Ltd. was established in Nagasu, Amagasaki, for the central purpose of repairing war-damaged machine tools and producing jigs and special-use machines. At the same time, support from other companies was solicited in order to strengthen production. In December the company participated in capitalizing Showa Seiki Kogyo in Minami-Shimizu, Amagasaki, and this company coordinated with the Kanzaki Plant in producing small marine diesel engines and their parts.

In 1948, the Juso Plant, established as a casting factory for SS diesel engine parts, went into operation. By capital participation in Koa Kikai Kogyo Co., Ltd. (Oyodo-ku, Osaka) in March and in Shoun



The Juso Plant starts running operations (1948)

Kosakusho Co., Ltd. (Komoe-Honmachi, Toyonaka) in October, the company endeavored to establish a system for increasing production.

## Entrance into the fishing boat engine market

It is said that “postwar Yanmar began with marine-use engines.” The foothold to recovery that the company managed to grasp was in the market for fishing boat engines.

For Japan, which had fallen into an extreme food shortage, the rehabilitation of the fishing industry, the primary source of animal protein, was one of the highest priorities. Supported by the government’s policies to increase food production, rehabilitation began with coastal fisheries.

In early autumn immediately after the war, President Yamaoka was asked by someone related to the former Japanese navy whether he would be willing to take on engineers from the navy to preserve the technology they had achieved and put it to use in peacetime industry. The candidates who were mentioned were Captain Motoaki Yokoi, later an executive managing director, who had been in charge of diesel engines in the Imperial Navy Technical Department, and several young engineers. All of them were specialists in the development and design of engines. President Yamaoka readily consented to accepting them, and it is no exaggeration to say that inviting such talented people and building on the basis of the high-level technology they brought with them lead to the prosperity of Yanmar today.

For the engineers, there could have been nothing better than to have a place to demonstrate the technology they had developed. So absorbed in work that they paid no attention to anything else, that is, being true craftsmen, this group, shortly after joining the company, were staying overnight in the single employees’ dormitory and immersing themselves in new marine engine research.

In January 1947, they completed the LB engine (5–7 hp), which was then Japan’s smallest vertical diesel engine. At the time, it gathered attention because it employed a daring airtight valve-in-head system and was equipped with the company’s own Bosch-type fuel injection pump and reverse clutch.

Production of the LB engine was carried out at the recently equipped Kanzaki Plant. In 1948 the factory put on the market the



Instruction manual of the LB model

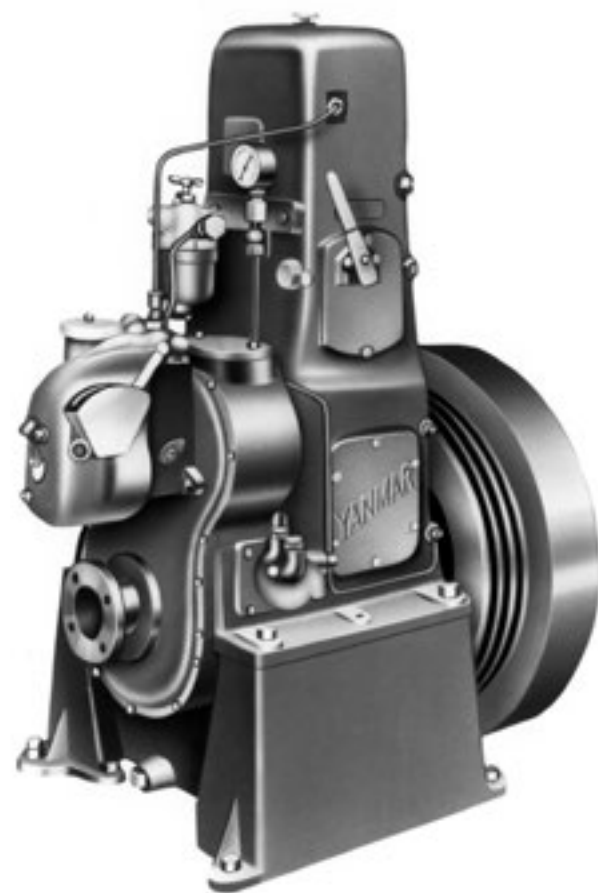

The LB model (5-7 hp)

2LB small marine diesel engine (2-cylinder 14 hp) as well as the SS series (3-10 hp), which was developed to be even smaller. From that time forward, the Kanzaki Plant expanded as the main factory for marine diesels.

In April 1951 the company put on sale the LD engine series (15-90 hp), which employed the country's first reduction reversing gear and an easy to operate reverse multiple disc clutch.

In those days most coastal fishing boats did not have engines and even if they were equipped with an engine, most of them were oil engines or hot-bulb engines which tended to have ignition failure when soaked by waves.

Diesel engines had a reputation for being heavy and expensive, and on top of that, because the company did not have broad name recognition, exhibitions were held at fishing ports in various parts

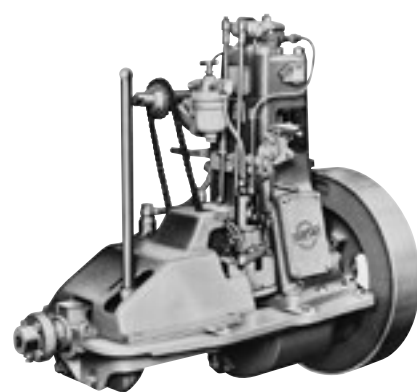

The SS 4 model (4 hp), 1948

of the country, making the appeal that what made the company's engines distinctive was their reliability—"they don't stop even when immersed"—and their economic efficiency—"their strength lies in low fuel consumption."

However, even if Yanmar carried out sporadic PR events, in the fishing villages where the majority of people were conservative, it was not easy to get them to accept new products. President Yamoka announced, "There ought to be a Yanmar base in every area where there are fishing ports," and spelled out a sales plan that was closely oriented to the local community. The company started up Yanmar dealer associations aimed at enhanced sales and after-sales service, and Yanmar repeat user associations aimed to increase customer loyalty.

These organizations succeeded, and the LB engine and SS engine took the place of oil engines that were mainstream at that time, and the LD engine replaced hot-bulb engines. The LD model not only served as a marine propulsion engine but also spread in use as an auxiliary engine (an engine to supply electricity on board), and as a generator for use on land and with pumps. It became the company's best-selling diesel.

Diesel engines began to spread rapidly in the fishing boat market. That being the case, other manufacturers could not remain silent. As new manufacturers entered the market, energizing the industry, enhancing engine power output became vital to differentiate Yanmar's products from those of competitors.

In January 1957 we put on sale the "Yanmar Tobiuo 6" ST95 engine (6 hp) which integrated a reverse gear and a reduction gear and employed a friction clutch. This new model engine, the first to have an informal name and with 1,400 rpm, was a revolutionary product suitable for lightweight, high-speed needs.

The company also put on sale in December 1959 the NTS70R engine (3 hp) and the NTS85 engine (4 hp) which were horizontal water-cooled engines with forward and reverse clutch attached. These two models were inexpensive and easy to handle and were designed to be used to power rowboats.

The company's marine engines, whose line-up had expanded, not only became known for superior performance and economy, attaining a favorable reputation for its substantial sales and service network, but also the Yanmar whirlwind became a sensation in fishing ports everywhere.

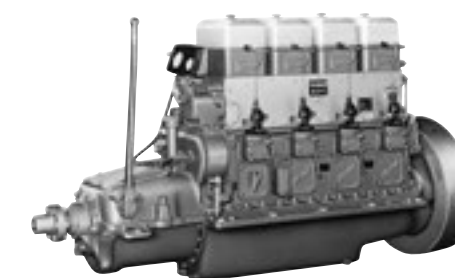

The 4LD model (60 hp)



A fishing boat equipped with the 4LD engine



"Yanmar Tobiuo 6" ST95 engine (6 hp)

## Advantages and disadvantages of trade with India

Accompanying the expansion of the marine engine business, exportation of products to India supported the company's recovery.

In August 1947, GHQ permitted resumed private foreign trade, and in May of the following year, through trading companies, the company began exporting products, focusing on the H diesel engine, to India, Pakistan, Thailand, Burma (present-day Myanmar) and the Philippines. Prior to the war, the company had exported oil engines and diesel engines to China and Southeast Asia, but following the war, as the various nations became independent and promoted agriculture and light industry, demand rose rapidly.

Export volume to India stood out particularly. The Indian government set about expanding arable land as a national enterprise and needed a large number of diesel engines to power irrigation pumps. The first peak in exports was a monthly figure of 230 million yen in August 1949. Immediately after the war, the exchange rate was US\$1 to 15 yen, but due to rapid inflation that rate leaped to US\$1 to 360 yen. That rate became fixed in April 1949 and for that reason profits from exports reached enormous figures.

This was a period when the government, aiming to obtain foreign currency, encouraged industries to export. There was great excitement within the company over the India trade boom. Centering around the Nagahama Plant, production continued night and day concentrating its capacity on exports.

However, the India foreign currency situation deteriorated and in November of that year orders suddenly ceased. Losing large-scale orders, the company, which had laid out a system for increasing production, was immediately caught in a serious predicament and unavoidably had to reduce the total number of employees by 30% in March 1950.

Exports resumed eight months later and in May 1951, monthly figures rose to 600 million yen and monthly exports were 5,000 units. However, this second peak turned out to be the last and exports to India were ultimately discontinued. The foreign currency situation worsened further and the government of India banned the import of engines of less than 20 hp.

During this period, exports to India totaled some 2.9 billion yen with sales of 26,000 units. While the marine market had begun to expand, at the peak, between 80% and 90% of total production was targeted primarily at India, so for the company this was a major blow. Needless to say, the sudden drop off in total sales was a problem, but even more severe was the disregard of the domestic market, especially the agricultural-use engine market.

It was not the fact that the company was unable to devote energies to engines for agricultural use because it was swamped with munitions production during the war but because of the instant postwar arrival of the India trade boom that the company's diesels were not able to advance upon the citadel of oil engines on the agricultural-use engine market. During that period, other companies plowed deeply into that market, expanding their market share further.

The conventional wisdom among farmers was that rather than using heavy, difficult to handle diesel engines, it was better to use the oil engines they were already familiar with. With things this way, the situation was grave enough that the company's destiny hung in the balance.

## Development of the lightest-weight K series

Driven to reduce personnel by 30% due to the over-dependency on the demand in India, President Yamaoka reflected deeply on the delay in responding to domestic markets and resolved to pour all of this energy into the company's true purpose: the development of agricultural-use diesels.



A sales shop in India



The advertisement of Saiga, a dealer in India



An assembly plant for diesel engines in India





Commemorating the development of the SF1 engine in front of the Osaka Head Office (1951)

In zeroing in on that market, the biggest issue was weight. At a time when oil engines weighed about 95 kg, the company's S2 horizontal water-cooled diesel engine was certainly too heavy at 150 kg. The company's dealers looked enviously at how well the oil engines of other companies were selling and some agents even called for a return to the oil engines that the company had manufactured before the war.

In June 1950, as the first step in grappling with this problem, the company completed the SF2 engine (2–2.5 hp). “SF” stood for “Small Farming” as it was a small-sized engine for agriculture.

A diesel engine that injected fuel in an atmosphere compressed under high pressure required a stronger construction than other kinds of motors and that inevitably made it large and heavy. To solve the problem of weight, it was necessary to reduce the thickness of the casting of the cylinder block, improve the air-tightness so that it would stand up under high pressure and raise the engine speed (rpm). To do this, they developed nodular cast iron, which exhibited sufficient strength despite being thin and improved air-tightness with precision processing by means of German-made machine tools. They increased the engine speed by shortening the piston stroke and achieved a reduction in weight. Nonetheless, the engine still weighed 125 kg.



The prototype of the SF 2 diesel engine (2–2.5 hp)

There was another problem besides that of weight. In order to clear away the image of the diesel as being difficult to operate, it was important to show that anyone could operate it, that it was easy to adjust, that it would stand up to long operation durations, and that it was reasonably priced. The engineering group occasionally engaged in vigorous debates as they devoted their energies to hammering out solutions to these problems.

In January of the following year, they developed the SF1 engine (2–2.6 hp), a smaller version of the SF2. It was less than two-thirds the weight of its predecessor and at 78 kg it compared favorably against the oil engine. In June, this was further improved as the K2 engine and was put on sale under the new model name “K series.”

The “K” was intended as a reference to “*karui*,” the Japanese word for “light,” and “*Klein*,” the German word for “small.” The model that symbolized this was completed in September 1952: K1 was the world's smallest horizontal water-cooled diesel engine (1.5–2 hp), at 55 kg. It was fuel-efficient at 240 g per horsepower per hour and it used a simple rope starter.

Thereafter, the K series grew into a line-up ranging from 1.5 hp–7 hp to fine-tune suitability to the needs of farmers.

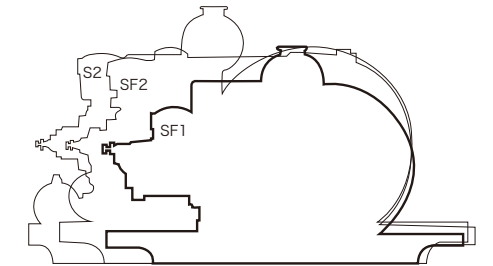

Comparison of the size of Yanmar's horizontal water-cooled diesel engines (1950s)

K1, the world's smallest horizontal water-cooled diesel engine (1952)



## Committing all possible effort to securing the agricultural-use engine market



A technical seminar



A Yanmar association in Yamaguchi Prefecture (1952)



The Tokyo Office showing the name "Yanmar Diesel"

The K series, which appeared during the golden age of oil engines, became a threat to the manufacturers of oil engines. After it went on sale, a negative campaign was launched to hold the company in check by claiming that diesel engines were heavy and difficult to start and vibrated strongly, that is, a campaign to emphasize the characteristics of previous types of diesels.

In other words, the K series was so revolutionary that it was having a major impact on the industry. Yanmar had absolute confidence in the product. Precisely for that reason, the key was to show a large number of people how excellent the engines' performance was and how easy it was to handle. A sales campaign was quickly launched.

The company started with technical seminars, in which Yanmar obtained the cooperation of universities and other institutions to explain the special features of the diesel engine. Beginning at Mie University in October 1950, these meetings made the rounds of dealers and agricultural organizations, with university professors and President Yamaoka delivering fervent speeches.

Without the cooperation of local dealers, achieving recognition and promotion would have been impossible, so President Yamaoka proposed establishing a shop in every 4 km-square area of the country. By taking measures to realize a network based on this guiding principle, agricultural Yanmar associations were organized in each prefecture, creating an environment that made it easier for the local sales agents to exchange information and otherwise communicate with one another. Further, the company built new business outlets in Kanazawa and Okayama as a means of strengthening the sales system.

The determination to use the opening of the sales of the K model as an occasion to mount an offensive in the agricultural-use engine market is visible in the action taken to change the company's name in February 1952. The new name "Yanmar Diesel Co., Ltd." was a simple combination of Yanmar's trademark and product and made it possible to determine the nature of the business at a glance. Until that time, Yanmar's brand and company image had not been unified, so there were frequently inquiries from customers and even dealers concerning what the connection was between Yanmar and

Yamaoka Nainenki (trans. *Yamaoka Internal Combustion Engines*). At the time, names written in katakana were rare and as a result, the new name succeeded in providing a corporate image of a "state-of-the-art engine manufacturer."

The company made arrangements for a surprising tactic as part of the campaign. From July through November 1954 Yanmar deployed a "helicopter campaign." This was a large-scale venture in which two chartered helicopters travelled the length of the archipelago, landing at farming and fishing villages throughout the country.

In advance of these visits, announcements would be made by advertising vans and radio, and dealers would hold demonstration exhibits of diesel engines and meetings with PR films. With regular customers of Yanmar products as a target, the dealers would borrow the playgrounds of elementary and junior high schools and provide helicopter rides. Between the helicopter rides, which amounted to some 4,000 hours, and multiple-channel PR, it was an unprecedented campaign and it drew a large response.

In addition to this, the company issued "Nagahama Plant Tour Invitations" to users from around the country in order to showcase the diesel engine. Dealers set up "diesel schools" where people would learn about the technology by dismantling and reassembling the horizontal water-cooled (*yokosui*) engines, putting forth considerable energy in activities to promote understanding. At the beginning, some 8,000 people per year participated in the factory tours and by 1956 that number had risen to 15,000.

By ceaselessly carrying out such activities, many users had an opportunity to really experience the performance of diesel engines, undermining the stronghold of oil engines.

While working on gaining agricultural-use engine market share with concerted efforts, the company also attempted a reworking of the production system for mass production of the K series. At the Nagahama Plant we endeavored to strengthen production capacity with combinations of over 500 specialty and multi-purpose machine tools and conveyors and by introducing rotary-type engine test benches. As a result, in December 1952 monthly output reached 4,000 units and a year later recorded 10,000 units per month. This achievement of mass production of small-type diesels was acknowledged and in April 1956 the company received the Okochi Memorial Production Prize.

Not only limited to the production groups, the efforts of the



The "helicopter campaign" (1954)



Nagahama Plant Tour





The Okochi Memorial Production Prize (1956)



Rotary-type engine test benches at the Nagahama Plant

development, sales and other groups contributed to company performance. Sales of *yokosui* engines were 24,000 in 1952 and two years later had increased to 68,000 units.

Following the K series, the company put new lightweight high-performance *yokosui* engines on the market one after another. The T series brought to fruition an innovative box-type design and a convention-breaking single flywheel. The NT series aimed at weight-reduction by employing aluminum die casting in the cylinder block. As a result of the appearance of these new models, it became easier to equip work machines such as power tillers and make a big step forward in mechanizing farming.

In addition to the agricultural-use engine market, the *yokosui* engine was adopted in the industrial-use market as well as a convenient engine used with generators and welding machines and to power concrete mixers and belt conveyors.

In 1960 the total production passed the 100,000 unit mark and in 1963 it reached the long-hoped for total of one million units. Thirty years after the completion of the HB model, Yanmar had finally created the “age of the diesel” in name as well as in substance.

A *yokosui* engine used to power concrete mixers

## Realizing the ideal of rural industry

The strength of the company in producing small diesel engines is integrated production of related parts such as fuel injection pumps. By achieving this, the concept that President Yamaoka had long nursed became a reality: “rural industry.”

The model for this was the clock-making industry in the villages deep in the mountains of Switzerland. The villages would enjoy economic benefits and the enterprise would enjoy the advantages of having a source of skilled labor.

The first construction site selected was Nagahara-mura, Ika-gun, Shiga Prefecture (present-day Nishiaza-cho-sho, Nagahama, Shiga Prefecture) near President Yamaoka’s birthplace. It was a secluded location, isolated and inaccessible by land during the extremely heavy snowfalls of winter. If you were carrying materials from Nagahama and the snows were deep, you would have to abandon your vehicle, put your knapsack on your shoulders and go on by foot.

At the same time, it was in a natural setting with clean air, making it the perfect place for processing precision parts. The local people enthusiastically welcomed the proposed venture and it would contribute to regional revitalization, so he decided that it was where he would build a modern factory.

In March 1949, the Nagahara Noson Seimitsu Kojo (present-day Nagahara Plant) opened as a specialized factory producing the vitally important fuel injection pumps and valves for small diesel engines. This factory attracted attention for demonstrating a new course of action for reviving agricultural villages, and in November 1951 Emperor Showa visited it during an on-site inspection in Shiga Prefecture.

In November 1952, in the same Takatoki-mura, Ika-gun (present-day Kinomoto-cho Ishimichi, Nagahama) the Ishimichi Noson Katei Kogyo (trans. *Ishimichi Home Workshops*) opened. Because this was built for the farmers of a village of less than 280 people which had no electricity, as the name of *katei* (home) conveyed, work at the facility was devised so that it could be done in intervals between the family business or could be divided up among family members.

Next to each dwelling, a bungalow-type workshop was constructed and there the workers processed parts for the diesel engines with diesel generators and machine tools relocated from the



Nagahara Noson Seimitsu Kojo (1949)



Operations at Nagahara Noson Seimitsu Kojo



Ishimichi Noson Katei Kogyo (1952)

Nagahama Plant. This unique project of making a living by combining farming with manufacturing was even mentioned overseas, and in June 1954 Prince Takamatsu paid an inspection visit to the village.

The Ishimichi Noson Katei Kogyo, which smoothly integrated industry with family businesses to help struggling farming families, was an embodiment of President Yamaoka's ideal, and it garnered wide support. Every year several thousand people who had heard about the initiative came to see it.

Following this, increasing the production of precision parts became necessary and in April 1960 the Omori Noson Seimitsu Kojo (present-day Omori Plant) opened in Takatsuki-cho, Ika-gun, Shiga Prefecture (present-day Takatsuki-cho, Nagahama) to specialize in fuel injection pumps, and the Nagahara Noson Seimitsu Kojo began to specialize in fuel injection valves. In May of that year, Sugaura Noson Katei Kogyo opened in Nishiazai-mura, Ika-gun (present-day Nishiazai-cho, Nagahama).

In addition to contributing to society through business activities, in November 1950, President Yamaoka poured his personal assets into establishing the Yamaoka Scholarship Foundation, an incorporated foundation, and assumed responsibilities as chair of the board of directors. Looking back on his own childhood, when he had wanted to go to school more than other children and learn many things but was unable to do so due to his family's situation, he founded this organization to support young people in the same circumstances who wanted an opportunity for higher education. Taking as its purpose "the cultivation of capable people who love their peaceful country and want to contribute to the enhancement of culture," the activities of the foundation, which confers stipends and loans to students from high school through graduate school, later expanded its target and now includes students from overseas.

### Launching into medium and large engine markets

After conquering the marine market with engines for fishing boats, the company began focusing on the increased demand for auxiliary engines for oceangoing ships. Within Japanese industry, technological innovation was advancing, and there was rapid growth centered on heavy industry, most prominently in shipbuilding and related industries.



Omori Noson Seimitsu Kojo (1960)

In December 1952, the Kanzaki Plant completed the 200 mm diameter cylinder 4MS(L) engine (120 hp), and the company entered the market for medium and large engines. This was followed by the construction of a new large-scale machine factory at the Kanzaki Plant in April 1953, and, in the following year, Yanmar carried out an ambitious investment in facilities to transfer the engine production departments from the Juso Plant.

In November 1953, the company put on sale the 6MSL-T "Yanmar Super Diesel" (270–300 hp) with an exhaust gas turbine supercharger attached. At the time, it was considered difficult to mount a supercharger on an engine with a cylinder diameter of 200 mm or less, but the company took the initiative with the model and went further by installing one on small engines. In addition, Yanmar took measures to differentiate products by adding multi-cylinders and intercooler-attached turbochargers and multi-valves to smooth the ventilation process in the interest of increasing power.

Further, with large fishing boats extending their areas of operation further into the deep seas and increasing the volumes of their hauls, there was an increasing demand for lightweight high-output engines. In February 1963, we supplied the 6M-T (300 hp) engine with an attached turbocharger to salmon and trout fishing boats in Kagawa Prefecture.

The medium and large-size engines also expanded the industrial-use engine market. Yanmar supplied large engines for auxiliary power sources to the Kansai Electric Power power plants to hoist gates and to the Cosmic Ray Observatory of Tokyo University on Mt. Norikura (present-day Norikura Observatory that belongs to Institute for Cosmic Ray Research of the University of Tokyo), Norikura Solar Observatory of Tokyo Astronomical Observatory, and Kansai Electric Power's Kurobegawa No. 4 Hydro Power Station.

### Diesel engines as a bridge of friendship between Japan and Germany

President Yamaoka made his second trip to Europe in February 1953 to visit Maschinenfabrik Augsburg-Nürnberg A.G. (MAN) and there he saw a magnificent bronze statue in the main entrance hall.

MAN was the first in the world to build a working diesel engine

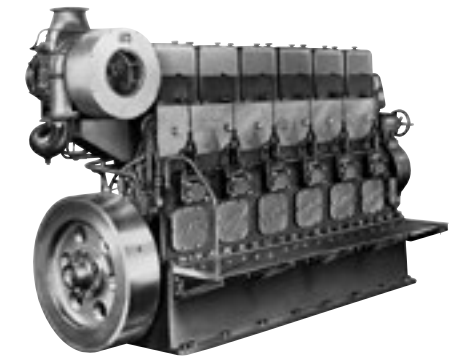

The 6MSL-T "Yanmar Super Diesel" (300 hp), 1953



Large engine-generators supplied to the Cosmic Ray Observatory of Tokyo University on Mt. Norikura





Dr. Diesel's son, Dr. Eugen Diesel visiting President Yamaoka in hospital (1954)

under the supervision of Dr. Rudolf Diesel. President Yamaoka held Dr. Diesel in high esteem and he bowed his head to the statue thinking it was Diesel. However, when he asked around, he found out that it was actually a statue of MAN's first president. No matter where he looked, however, he could not find a statue of Dr. Diesel. Thinking this odd, he asked and found out that because Germany was a Catholic country which looked down on suicide, there was a certain negative feeling toward Diesel, who had cast himself overboard from a ship crossing the Strait of Dover, so no statue or tomb had been erected for him.

President Yamaoka wrote, "Whatever the reason might be, it was dreadful that here in the land of his birth there was neither a statue nor a tomb for the inventor of the diesel engine which has made such a valuable contribution to the industries of the world." (*Watasbi no Rirekisbo*) Lamenting this fact, before he set out for home, President Yamaoka offered, through a member of the board of MAN, to donate to the city of Augsburg a bronze statue of Dr. Diesel.

The following year, Dr. Diesel's son, Dr. Eugen Diesel, who had heard the story, visited Japan. President Yamaoka was recovering from illness at the time and the younger Dr. Diesel called on him to inquire after his health.

Diesel took Yamaoka's hand and said, "It was my departed father's earnest desire to provide a small, efficient engine to small-scale enterprises, and your efforts accomplished what he set out to do. You yourself are my father's true son." (*Watasbi no Rirekisbo*)

'I have not been wrong in the path I believed in and traveled. Even though we came from different countries and speak different languages, Dr. Rudolf Diesel and I have the same ideal,' President Yamaoka thought to himself. A flood of emotions welled up within his heart. Eugen then took out his father's treasured inkwell he had used when he drew up the designs for the diesel engine and his father's treasured cane and presented them to President Yamaoka as a memento of his deceased father.

After Eugen Diesel returned to Germany, he went to great effort to let people know about the great achievements of President Yamaoka, and as a result, in April 1955, the German Inventors' Association honored President Yamaoka with the Diesel Gold Medal. The prize was awarded to scientists and inventors with exceptional achievements in technology and industry and President Yamaoka was the first non-German to be recognized with the award.



Awarded the Diesel Gold Medal (1955)

In the following year, 1956, at the request of the Deutsches Museum in Munich, he donated a section model of the K1 engine, the world's smallest diesel engine at the time. It was exhibited alongside the very first diesel engine produced by Dr. Diesel. President Yamaoka was nominated to be an honorary member of the board of the museum.

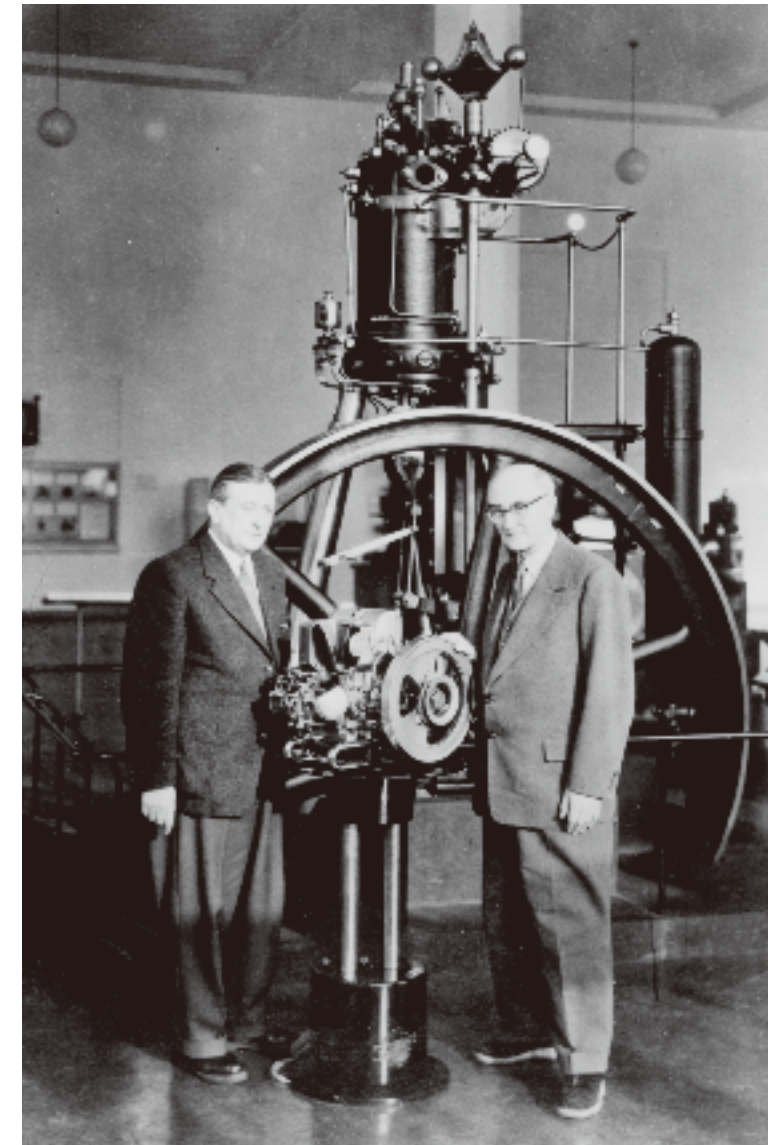

A section model of the K1 engine donated to the Deutsches Museum at their request in 1956. The model was exhibited alongside the very first diesel engine produced by Dr. Diesel. (left, right) Museum representatives





Awarded the German Cross of the Order of Merit (1957)

The amicable relationship, which began with the plan to donate the statue of Dr. Diesel, spread even further to become an international exchange. President Yamaoka assumed office as head of the board of directors of the Japanese-German Cultural Institute, an incorporated foundation, and made efforts to promote ties of friendship between the two nations.

In April 1957, to honor these sustained activities, West Germany presented him with the country's highest honor, the German Cross of the Order of Merit.

As discussions of the offer of a donation of a bronze statue of Dr. Diesel continued, the memorial evolved into a Japanese stone garden. A dry landscape garden, with 56 exquisite garden stones, including a megalith weighing more than two tons was to be constructed in a garden in Augsburg.

The design was supervised by the architect Junzo Sakakura. Professor Kazuo Kikuchi of Tokyo University of the Arts was commissioned to carve on the megalith a likeness of Dr. Diesel together with a dedicatory message in German by President Yamaoka which read, "Dr. Diesel, you and your work live on, throughout every hill and vale of Japan."

On October 6, 1957, some 600 prominent local citizens and the ambassadors of Japan and Germany assembled in the city's public hall to conduct the dedication of the memorial garden. Following this began a procession to the Wittelsbacher Park for the official opening of the stone garden.



Relief of Dr. Diesel



President Magokichi Yamaoka (left) on the way to the opening ceremony with Mayor Nikolaus Müller of Augsburg (1957)

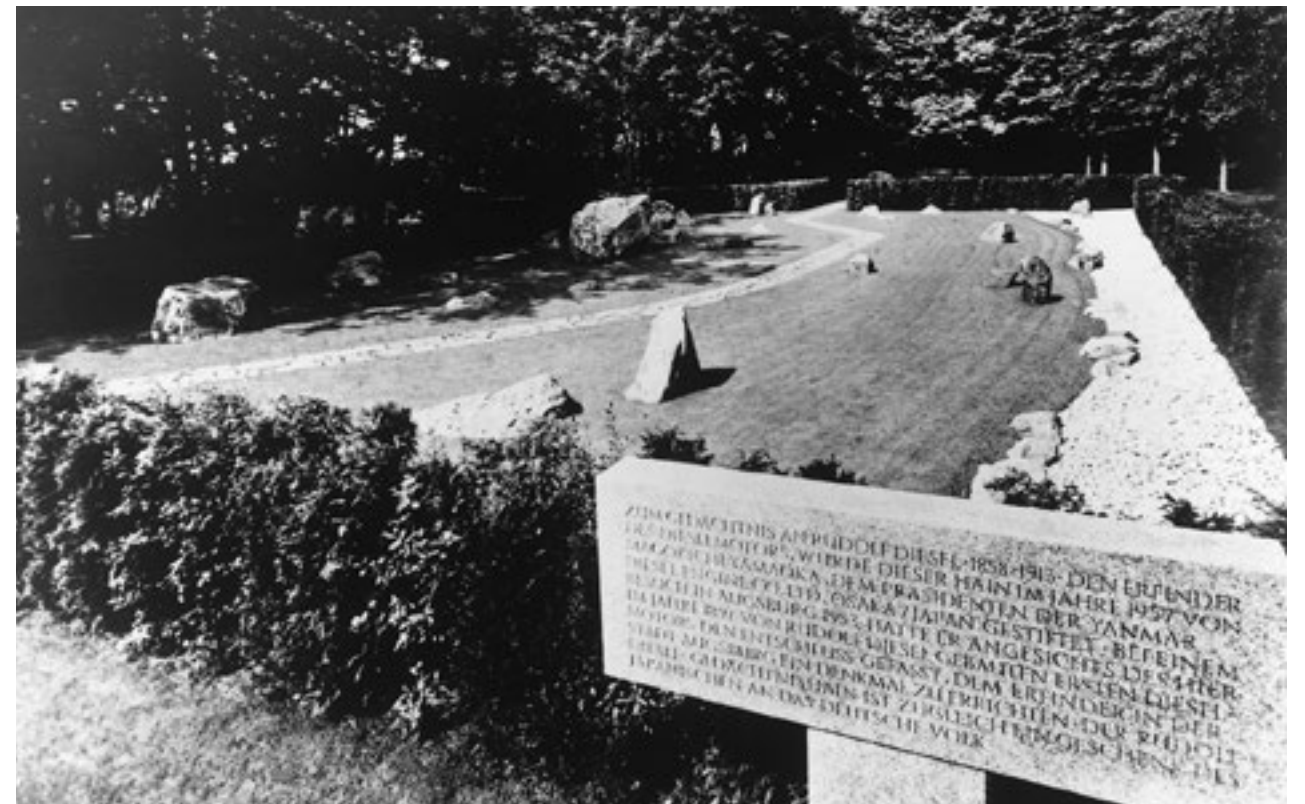

A Japanese stone garden commemorating Dr. Diesel donated to the city of Augsburg (1957)

About 50,000 people gathered along the roadside. Joyful cheers and applause echoed repeatedly through the Wittelsbacher forest and along the roadside children waved Japanese flags, under the dazzling sunlight on that clear autumn day in southern Germany.

President Yamaoka later wrote down his memories of that occasion. “That procession was, for my wife and me, a previously unimaginable, once in a lifetime occasion. An elderly farmer-turned-engine-manufacturer from a small village in the Kohoku area of Shiga Prefecture, unexpectedly parading triumphantly along a street in a foreign country.” (*Watasbi no Rirekisbo*)

A resounding fanfare echoed and Yoshino, his wife, cut the ceremonial ribbon opening the garden. The national anthem *Kimigayo* was played and as he stood before the relief of Dr. Diesel shaking hands with Mayor Nikolaus Müller, streams of tears ran down President Yamaoka’s cheeks.

Not only did this stone garden honor the achievements of Dr. Diesel but it also became the foundation for friendship between people in Japan and Germany, and that remains unchanged in Augsburg today. With that donation as a turn of fate, in April 1959, the city of Amagasaki, where one of Yanmar’s main plants is located, and the city of Nagahama were tied to Augsburg as sister cities. Since that time, active international cultural exchanges have continued.

### Vice President Yasuhito Yamaoka’s innovative business expansion

After falling into poor physical condition at the end of 1953, President Yamaoka spent much of his time resting in bed. As a consequence, his eldest son Yasuhito Yamaoka, who had become vice president in March 1945, took on the central role in business operations.

Vice President Yasuhito Yamaoka had supported his father through the company’s hardest period, from the last days of the war through the postwar years, but he saw business operations from a point of view that differed from that of his father’s. He felt that business in the future would have to be modern in every respect. Believing that reforms were necessary in order to achieve that, he very quickly set out to improve personnel training and in-house organization. From the period of high-growth onward, he actively



Vice President Yasuhito Yamaoka

branched out into new projects and even into projects overseas.

In addition to a flexible vision of things and excelling in perceiving future changes, he made the most of his distinctive qualities by not clinging to diesel projects but taking measures to expand beyond the current sphere of enterprise. He was also enthusiastic about employing new media, including radio and television.

In the organizational aspect, he took on two major issues. One was the reorganization of the sales department according to markets.

In the mid-1950s, the company’s business had diversified into agricultural-use, industrial-use and marine-use engines. Previously the sales department exerted centralized control over all of these, including the overseas component, and Vice President Yamaoka came up with the idea of reorganizing sales according to markets. In addition to the fact that it had become necessary to cope with an expanded scale in each market and an increased variety of machines for sale, another objective was to introduce the principle of competition within the company itself.

In December 1957, the sales department was modified so that the First Sales Department assumed responsibility for the agricultural-use engine market, the Second Sales Department handled the industrial-use engine market and the Third Sales Department covered the marine-use engine market, and the branch office organizations responded accordingly. This reorganization resulted in a clarification of systematic responsibility in each market and fixed the information route that tied customers, dealers, branch offices, and head office that connected each market.

A second major issue was the establishment in April 1958 of Japan Marine Equipment Co., Ltd. (present-day Yanmar Engineering Co., Ltd.)

As noted previously, the company aimed at developing—following the marine small engine market—a market for medium and large-scale engines as auxiliary power for oceangoing ships and fishing vessels.

Essentially, engines for oceangoing vessels were handled by the Third Sales Department, but because that department had its hands full with sales of small marine engines, in its place, that business was covered by the Second Sales Department which handled land-use generators.

However, although they were dealing with the same engine for generating electric power, the demographic for industrial-use and



An oceangoing cargo ship



Engine room in an oceangoing cargo ship



marine-use engines were entirely different. Judging from market trends, the future demands for oceangoing auxiliary engines were expected to be bright, but with a hastily constructed system, positive sales activities were not possible.

Vice President Yamaoka decided that the establishment of a special unit for medium and large-scale marine-use engines was essential. Employing his wide-ranging connections, he established Japan Marine Equipment, a joint venture with cooperative equity investment from the company and seven major shipping companies. Placing it under the wing of the company's marine-use dealerships, it was an attempt to sell auxiliary engines to shipbuilders and marine transport companies through dealers.

Putting together the manufacturer and the customer (i.e. marine transportation companies) was an unprecedented, entirely unique business model. The company's full-scale entrance into the medium and large-size marine-use engine market began with this move.

Even in terms of product development, Vice President Yamaoka's forward thinking was outstanding. As a strategy for expanding sales of the *yokosui* engine in the latter half of the 1950s, selling agricultural machinery and construction machinery in sets was taken into consideration following development of mini-size diesel powered pickup trucks in the newly established Vehicle Department, later to be named the Machinery Department. Taking on vehicle production was a result of Vice President Yamaoka's strong determination.

Every part, including the body, was produced by the company, and after a series of prototypes and improvements, the company completed the agricultural-use "Yanmar Pony" FM model which could carry a load of up to 300 kg with a diesel engine on the back that was portable and could be used for farming and construction work.

However, because it came on the market at the same time that power tillers were spreading, sales did not grow, so the portable generator was eliminated, the loading platform was expanded and a standard KYT mini-size pickup truck was put on sale.

This vehicle became the forerunner of the domestic mini-size four-wheeled trucks, but after being caught up in the fierce competition with other vehicle manufacturers, the company was compelled to withdraw from that line of business. The technology attained through the research and development, however, was put to practical use later in the development of tractors.



"Yanmar Pony" FM model

Development of the rotary engine was another epoch-making challenge. Because there was no vibration from reciprocating motion, in principle it was the most highly efficient engine. Focusing on the ease with which it could be reduced in size and weight, Yanmar explored its potential for becoming "the second diesel."

The company signed a technology agreement with NSU Automobil A.G. (NSU) and Wankel GmbH in February 1961 related to rotary engines. In November of that same year, a rotary internal combustion engine research center was established at the Nagahama Plant. In April 1969, it completed the world's first rotary outboard engine, R220 (22 hp), opening the door to practical implementation. However, its fuel efficiency compared unfavorably with a four-cycle gasoline engine, and because of the need for saving energy following the 1973 oil crisis, plans to commercialize the product were suspended.

Among the projects Vice President Yamaoka came up with, there is one that the Japanese people are highly familiar with: the "Yanboh & Marboh Weather Forecast" started in June 1959.

The intent behind the production of this program was to actively employ the media of television, which was rapidly spreading, to popularize the Yanmar brand. Regardless of age, gender, occupation or position, everyone would watch the weather forecast. The "Yanboh & Marboh Song" that accompanied the program was one that people would hum and the Yanboh and Marboh twin boy characters gained popularity. In 1969 the program was broadcast on 39 stations immediately raising the company's name recognition and improving its corporate image.

### The "Second Yanmar" in Brazil

Following the suspension of exports to India, the company's enterprises abroad entered a slump. In 1952 the head office established a Trade Department, but its main operations were sending products to Korea, the Philippines, Burma (present-day Myanmar) and Vietnam, as a portion of war reparations.

In the second half of the 1950s, in addition to this reparations route, exports via trading companies rose significantly, and the company's products began to earn a good reputation.

At that time, overseas business was centered in Asia, but Brazil



A rotary outboard engine, R220 (22 hp)



Yanboh & Marboh Weather Forecast broadcasted on the national television (1959)



Yanmar Diesel Motores Do Brasil



Inside the factory of Yanmar Diesel Motores Do Brasil

was an exception. The Brazilian government was active in attracting foreign capital. The main reasons for launching into that market were the country's vast territory and rich marketability, but also at work was the fact that President Yamaoka had for a long time felt an affinity for Brazil because large numbers of Japanese emigrants had settled there.

Further, from the bitter experience of losing factories and equipment during the Pacific War, he had begun to embrace the idea of "creating a 'Second Yanmar' in a country with a stable government and economy" and Brazil was singled out.

In May 1950, the company began exports to Brazil and in February 1957 it established Yanmar Diesel Do Brasil Ltda. in São Paulo as its first overseas subsidiary. Initially, its main activities were sales and service, but in June 1960 it was reorganized as the production and sales entity Yanmar Diesel Motores Do Brasil S.A. and small diesel engine production commenced at a factory completed in Indaiatuba, São Paulo.

### Establishment of Yanmar Agricultural Equipment Co., Ltd.

Japanese agriculture, with the exception of the chaotic immediate postwar period, supported by government policies, increased agricultural yield, attained a favorable recovery and developed, reaching a major turning point with the arrival of the period of high economic growth. The secondary sector of the economy centering on heavy and chemical industries expanded, while the primary sector of the economy such as agriculture declined sharply. The income gap between urban laborers and farmers widened, population flowed out of the countryside into urban areas, and farmers began taking on side jobs to supplement their income.

Although the farming population was decreasing, in general, the amount of rice harvested steadily increased. Accompanying the enactment of the Agriculture Mechanization Promotion Law and the Agricultural Basic Act, with financial subsidies the diffusion of agricultural machinery increased. The primary factor in this was the prominent improvement in productivity.

Mechanization began with powered threshers, rice hullers and pest-control equipment but it was the power tiller that really



Operating a powered rice-huller

opened the door. The introduction of machinery into the labor of tilling the soil, which until that time had been done by the labor of oxen, horses and humans, could safely be called a major revolution in the history of Japanese agriculture. Every manufacturer competed ruthlessly to develop and commercialize a comprehensive mechanization of the entire process of rice cultivation.

As a turning point in mechanization approached, the company faced a major decision. Up to this point, companies had built up independent sales networks for engines and tillers, but at this stage, the sales of tillers and engines as a single unit were becoming noticeable, and leading engine manufacturers were aggressively promoting affiliations.

The company's dealers were also encountering difficult circumstances in separate item sales. As a result, there were heated discussions daily among the sales personnel regarding whether they should produce their own tillers for sale or pursue an affiliation with tiller manufacturers.

President Magokichi Yamaoka indicated an aggressive course for action. "If I were 10 years younger, I would probably build my own tiller. But rather than doing that, I want to make a tractor that will become the core of agricultural machinery." Meanwhile, Vice President Yasuhito Yamaoka decided on a plan of action that, while not producing tillers independently, would still sell them under the Yanmar brand.

To produce one's own machines and catch up with manufacturers with a solid head-start would require a large investment and considerable time. Instead, the company appealed to several leading agricultural machine manufacturers and pursued the path of cooperation.

It considered a wide range of options from business alliances to mergers. The negotiations proceeded with difficulty. Eventually, however, a plan was drawn up whereby the company would supply small diesel engines and agricultural machine manufacturers would produce the tiller. Sales would be carried out by a newly established company. The company and the business partner began preparations for establishing the new enterprise.

In July 1961, the First Sales Department, which handled the agricultural-use engine market, was transformed into an independent entity, Yanmar Agricultural Equipment Co., Ltd. The two initial participants in this cooperative venture were Fujii Seisakusho Co., Ltd. (Okayama, Okayama Prefecture), a pioneer in tillers, and



A tiller equipped with a horizontal K engine





The opening ceremony of Yanmar Agricultural Equipment (1961)

Kyowa Noki Co., Ltd. (Nagaoka-gun, the present-day Nangoku, Kochi Prefecture), which produced rice hullers and threshers.

Somewhat later they were joined by Takeshita Tekko Co., Ltd. (Yanagawa, Fukuoka Prefecture), which had put on the market a series of top-of-the-line tillers, and New Delta Industrial Co., Ltd. (Mishima, Shizuoka Prefecture), a prominent maker of pest-control machinery.

The new company was capitalized at 500 million yen and Vice President Yasuhito Yamaoka assumed the position of president. The head office was located inside Yanmar Diesel. The four machinery manufacturers concentrated on production and the sales functions of each were transferred to the new company. All products were unified under the Yanmar brand, which had business dealings with 795 stores at the outset, preeminent in scale in the agricultural industry.

Yanmar Agricultural Equipment brought together the company's and partners' strengths, and as a prospective "comprehensive agricultural equipment manufacturer" it took as its objective full-scale equipment manufacturing, going beyond just tillers.

## The successive deaths of founder and second company president

President Magokichi Yamaoka passed away from heart failure on March 8, 1962. A solemn funeral and farewell ceremony were held at the Abeno Funeral Hall on March 16.

He died at the age of 73. For his contributions to industry and culture, he was granted the Senior Fifth Rank, and awarded the Third Class of the Order of the Sacred Treasure.

Starting business with the sale of used gas motors, continuing with the production of oil engines and eventually developing the first small diesel engine in the world, his life, in which he poured all his enthusiasm can certainly be called "a life devoted to engines." He maintained throughout his life his original intention to reduce even a little bit the heavy labor of farming and fishing and do it with less, inexpensive fuel, and this became the foundation for all the company's businesses.

He possessed resourcefulness, was bold and big-hearted, and was highly considerate of others. He loved originality and a pio-

neer spirit and was a determined man who was not disheartened by adversity or failure. When it came to new challenges, he maintained his beliefs, completely devoted and indifferent to what people around him might say, and he was obstinate in his convictions. He was an enterprising person with optimism that paid no heed to the past, ceaselessly looking toward the future.

In his later years, one of his favorite mottos was "Grateful to serve for a better world." He wrote in *Watashi no Rirekisho*, "Whereas I accept that luck, or the lack of it, can play a significant role in someone's life, I believe that if we continue our efforts sincerely and with gratitude in our hearts, opportunities and collaborators will make themselves apparent, towards realization of a better, more beautiful world."

Eleven days after President Yamaoka passed away, on March 19, 1967, Vice President Yasuhito Yamaoka took office as the second president of the company.

"We have lost our great founder," the new president said to a gathering of all the employees, "but it is my intention to permanently employ his spirit together with all of you. Our former president, no matter what the circumstances were, was a person of good intentions who from beginning to end acted with sincerity. He was a hard worker who devoted himself wholeheartedly, ardently and enthusiastically toward his work. And through his great ideal of "To conserve fuel is to serve mankind," he dedicated his whole life to inventing and popularizing small diesel engines. On the occasion of my succeeding to the founder's great achievements and our splendid 50-year history, it is my intention to inherit the former president's spirit and to devote my energies to the development of Yanmar Diesel not only here in Japan but around the world."

Three months prior to this, on the occasion of the 50th anniversary of the founding of the company, a new head office building had been completed on the site of the company's founding in Chayamachi, Kita-ku, Osaka. A ceremony to commemorate the anniversary had been planned for March, but due to the founder's passing, the ceremony was postponed for a year and was held at the Umeda Koma Theater, Osaka (present-day Umeda Arts Theater) in April 1963.

The documentary film of Magokichi Yamaoka's life, *Watashi wa ikite iru* (trans. *Living My Life*), was shown at the ceremony and those who attended once again recalled the founder's tremendous



"Grateful to serve for a better world"



The Head Office building



A ceremony to commemorate the 50th anniversary

achievements. It was announced that as 50th anniversary projects the company would create Yanmar Gakuin aimed at successors in dealerships and managerial employees for research in both business and technology and would also create a research center.

Having realized substantial dieselization in the agricultural-use engine market and marine-use engine market, the company, under its new president, intended to make another leap forward.

However, only a year and a half after assuming office President Yasuhito Yamaoka suddenly passed away from cardiac arrest on October 24, 1963. He died at the age of 46. Everyone was stunned and mourned his premature death.

He was a person of keen insight who could precisely grasp trends in society and Japan's future. The various decisions he made in business became the foundation for the company's major development as a comprehensive machine manufacturer. He took as his favorite motto the words of the Period of Warring States military commander Shingen Takeda: "People are the castle. People are the stone walls. People are the moats." Putting high value on coexistence and co-prosperity among dealers and on harmony within the company, he acted with complete sincerity toward everyone he had ties with. While his term in office was short, the distinguished service he rendered to the company was incalculable. For the accomplishments he achieved during his lifetime, he was invested with the Junior Fifth Rank and granted the Fourth Class of the Order of the Sacred Treasure.

## Modernization of Management and Entrance into the Industrial Machinery Market

*1963-1972*





The Tokyo Olympic Games held (1964)



The Osaka 1970 World Expo

#### HISTORICAL BACKGROUND

In 1964, Tokyo hosted the first Olympic Games ever to be held in Asia, giving Japan an opportunity to be recognized worldwide as an advanced country. Massive national projects were initiated, and infrastructure, such as the Meishin Expressway and the Tokaido Shinkansen Line, was built at a furious pace bringing enormous economic prosperity to the country.

Once these large-scale public works projects slowed down, the Japanese economy went into a temporary recession, but it bounced back in a year and entered a boom period called the “Izanagi boom,” which lasted 57 consecutive months. From 1966 to 1970, Japan recorded an astounding annual real economic growth rate of over 10%, and in 1968, its gross national product (GNP) exceeded West Germany’s to become the second largest in the world.

However, due in part to monetary restraint by the Bank of Japan, the economy gradually declined, and the rapid economic growth period came to a close after the Osaka 1970 World Expo, leaving behind serious environmental issues, including air, water and noise pollution.

In July 1972, the Tanaka Cabinet was inaugurated. The Cabinet initiated a “Plan for Remodeling the Japanese Archipelago” and implemented measures to expand domestic demand, mainly through investments in rural areas. This triggered a development boom and business did improve, but it also caused inflation and failed to stabilize the economy.

## Appointment of Tadao Yamaoka as the third president

On October 28, 1963, Executive Managing Director Tadao Yamaoka was appointed the third president after the sudden death of the second president, Yasuhito Yamaoka.

Tadao was born as the second son to Magokichi Yamaoka on November 28, 1925. Thirty-seven at the time of his appointment, he was a youthful and energetic president.

This turn of events was something that no one, including Tadao, had imagined until a few days earlier. Even so, when the time came for his speech accepting the post, he spoke with determination, already displaying the attributes of a responsible corporate leader. He declared in a firm, strong voice, “I want to work with all of you toward our goal of developing Yanmar into a leading company in name and reality, not only in Japan but in the world.”

His first mission as president was to modernize the company’s management.

Japan’s rapid economic growth inevitably brought about dramatic changes in people’s lifestyle and industrial structure. As businesses expanded and became more complex within Yanmar, the management style of the first president, Magokichi Yamaoka, in which a charismatic figure ran everything, was reaching its limits. The second president, Yasuhito Yamaoka was quick to acknowledge this and formulated a management strategy to address the needs of the coming age. After his all-too-early death, Tadao Yamaoka, the new president, who had until then assisted his older brother, inherited his ideals.

The first thing he did was to carry out a large-scale organizational reform. In order to strengthen product development capacity to better respond to the increasingly competitive market conditions, the Product Planning Department and the Development Department were newly created. To enhance sales, the Sales and Marketing Division was established by consolidating all the sales departments, and new departments organized by function, such as the Planning Department, Sales Promotion Department, and Sales Engineering Department, were created and placed under its control. Furthermore, the Overseas Trading Department was expanded and made into a completely independent division under the direct control of a director in charge.



Tadao Yamaoka making an inaugural speech as the third president (1963)





Business Management Policy  
compiled for 1965-1986

As a corporation grows larger in size, it becomes more difficult for its leader to communicate his thoughts and beliefs to all the employees, and to share his ideas and policies with them. As the first step in coping with this problem, President Yamaoka established the President's Office, a department specifically for the purpose of shaping and formulating the President's policies and management plans. He then set up a system that allowed him from the beginning of 1965 to quickly communicate the company's Business Management Policy which included strategies and sales goals for the fiscal year, to all the departments by giving explicit explanation to the directors of the head office, division managers, branch managers, plant managers, and others.

In 1968, he drew up a five-year plan and established the company philosophy, defining the company's basic stance and management policies for the future. The company philosophy consisted of three components: objective, creed, and spirit. The "objective," which clearly stated the company's business areas and social mission, read, "With diesel engines as the foundation of our business, we will strive to popularize economical engines, to modernize and improve efficiency of agricultural, manufacturing, and fishing industries, and to contribute to the development of world culture."

While moving these plans to action, President Yamaoka also began visiting dealers all over Japan.

"There is probably much to be learned by actually going to the sites and getting a true feeling of what it is like working on the front line." With this thought in mind, he made time even during the busiest periods to visit local dealers and listened carefully to the opinions of store managers and customers. This tour, which began in February 1965, lasted for nearly four years. He went to the regions of Kyushu, Shikoku, Chugoku, Kanto, Tohoku and Kinki,

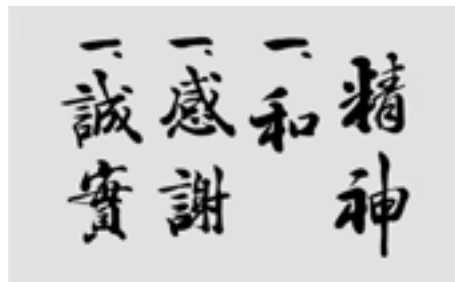

The company philosophy (spirit): harmony,  
gratitude and loyalty (1968)



The company philosophy (creed): It consists of maintaining the traditional spirit of antidiscrimination, placing priority on customer loyalty, working toward creative technology development, raising Yanmar's reputation, working together for mutual harmony and benefit

and visited more than 70% of all the dealers in Japan.

What he found were many problems at the sites that he would never have known just by reading through documents. An especially serious problem was the disparity in the specifications of agricultural equipment.

Because Yanmar Agricultural Equipment, of which he was serving as the concurrent President, had begun as a consortium of Yanmar and four other agricultural machinery manufacturers, each dealer was still moving in the shadows of its parent manufacturing company. The main product at the time was the power tiller, but since each manufacturer was independently developing its own tiller, there were no standard design or parts. This meant, for example, that when a customer requested repairs, a dealer had to get parts from three companies just to replace a single belt.

Each time President Yamaoka went on an inspection tour, he held discussions till late into the night with the engineering and sales personnel of the Yanmar Group companies that had accompanied him, and taking up problems one by one, sought measures to solve them. In this way, he brought to light the fact that the core of the problem lay in the differences in development concept and the lack of uniform standards.

To solve this problem, he established a research & development center in Yanmar Agricultural Equipment in July 1965, bringing together engineering personnel from Yanmar Agricultural Equipment and its tiller manufacturers, Fujii Seisakusho, Kyowa Noki, and Takeshita Tekko, to set engineering and technical standards and to develop new products under a unified concept.

## Awarded the first Deming Prize in the industry for company-wide quality control activities

Among the many things acquired from visiting dealers was valuable information that later formed the pillars of management.

By paying close attention to the voices of dealers and customers regarding their products, it became evident that the most important factor deciding the destiny of a manufacturer was "quality." Dependable quality was what made a brand trustworthy. But in order to always supply high quality products, it was necessary to promote quality control from a company-wide perspective.



President Tadao Yamaoka visiting agricultural  
equipment dealers (1965)



President Tadao Yamaoka observing the marine  
market (1965)



A research & development center established in  
Yanmar Agricultural Equipment (1965)

In announcing the company's annual Business Management Policy at the year's start in 1966, President Yamaoka declared, "From now on, all the products delivered to the market must be 'guaranteed consistent quality under consistent quality control,'" and he gave instructions to enhance quality control efforts.

Quality Control (QC), which was introduced by the U.S. military forces after the Second World War, had developed in a unique way in Japan, and at the time, "Zero Defects" (ZD) and Quality Control (QC) activities were being pursued. However they were limited primarily to manufacturing sites. It was the same at Yanmar, and when quality control was first adopted in 1954, it was applied only to the production departments. However President Yamaoka made it clear that from then on, he himself would spearhead the effort to promote quality control activities in all the departments.

What he was talking about was total quality control, which aimed to maintain and improve quality by improving the quality of corporate tasks not only in the production departments but throughout the whole company, and by properly managing purchasing and manufacturing costs. This is common practice today, but at the time, it was still little known. Yanmar, in accordance with its Business Management Policy, established the Total Quality Management Committee in March 1966, and "YQM (Yanmar Quality Management)" activities were initiated in the departments of all group companies, including affiliated companies.

In June of that year, the "YQM Promotion Guide" was distributed to all employees, and small group activities were started in each workplace with the express intent of improving job quality and ensuring zero-defect manufacturing. Specialists from outside were often invited to give instructions and lectures, and YQM activities got well under way in less than a year. Not wanting to miss this opportunity when awareness had been raised throughout the company, President Yamaoka set a concrete goal of winning the Deming Application Prize the following year.

The Deming Prize is a prize, established in 1951 by the Union of Japanese Scientists and Engineers to enhance quality control in the manufacturing industry, which is awarded to individuals and corporations recognized for their contributions to quality management. The Deming Application Prize is a prestigious prize given to corporations that are judged, after rigorous investigation, to be appropriately implementing total quality control.



YQM Promotion Guide (1966)

In November 1968, the company became the first diesel engine manufacturer to receive the Deming Application Prize. In most companies, sales and clerical workers resisted the introduction of quality management, because they were unfamiliar with the idea. But at the company, every department fully understood from the beginning why quality control was necessary, and worked together as one to get results. It was this point that was highly evaluated.

Even after winning the award, President Yamaoka continued to raise awareness of the importance of quality control and made efforts to promote and establish YQM activities.



Explaining YQM to the review board (1968)

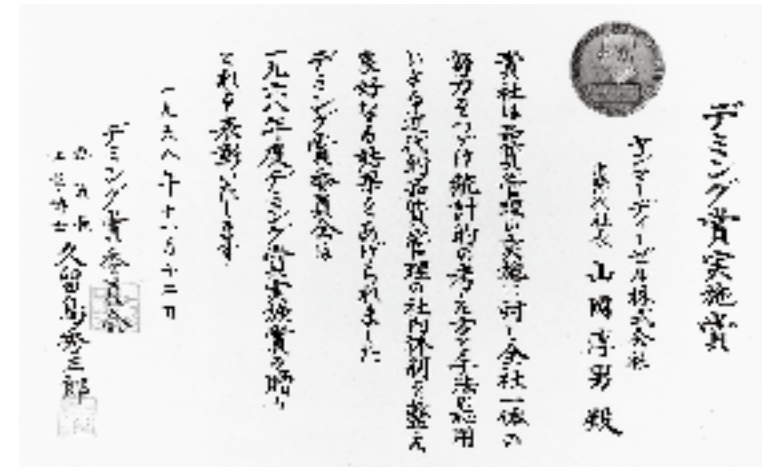

The Deming Application Prize certificate (1968)



The Deming Medal

## Standardization of the tiller and the tractor business

The newly established research & development center, consolidating the technology and know-how of Yanmar Agricultural Equipment and affiliates, completed the Y series (YC and YS) diesel-powered tillers and launched them in May 1966.

In developing these products, a special focus was placed on matching the engines with the equipment. This was because previous tillers did not have an optimal front-rear weight balance, and were therefore difficult to turn. Not only that, they lacked unity in design.

The Y series tillers were equipped with new FE horizontal water-cooled diesel engines developed specifically for tillers. Further, responding to the need for quicker speed change and reverse function due to diversification of farming operations, an innovative





The Y series diesel tiller



I-style vertical transmission

direct control (I-style) vertical transmission was developed. It had 6 forward and 2 reverse speeds controlled by a single shift lever.

The Y series, with its easy maneuverability and functionality, earned overwhelming support from farmers. Since engines and tillers were rarely developed together at the time, there was no denying that tillers were difficult to handle and that they malfunctioned from time to time. But the Y series solved all these problems. In 1968, it recorded explosive sales of more than 100,000 units, accounting for over half the market share in Japan.

The success of the Y series boosted the growth of Yanmar Agricultural Equipment, and in 1967, the company increased sales to 30.6 billion yen, rising to the top of the industry. The Y series proved to be long-selling products and continued to sell for 15 years.

Meanwhile, in the latter 1960s, when the tiller was at the peak of popularity, various companies in the industry began launching other farm equipment that they had developed over the years, including the tractor, the combine, and the rice transplanter.

The most important among them was the tractor. Because the arrival of the rapid economic growth period had caused a shift from primary to secondary sector of the economy, the government was considering subsidies and the introduction of high performance machinery to make up for the decrease in agricultural workforce. The First Agricultural Structure Improvement Project, which began in 1962, predicted that the riding tractor would be the central equipment for agricultural work in the near future, and “No tractor, no survival” became a common understanding in the industry.

At the newly established Yanmar Agricultural Equipment, entry

into the tractor business had been on the table from the very beginning, and by 1963, each of the affiliated companies had developed its own tractor. However Yanmar Agricultural Equipment knew that they would not be able to survive in the extremely competitive growing tractor market if they left the production of tractors to its affiliates. On the other hand, it was also difficult for them to develop and manufacture tractors alone. A full-scale entry into the tractor industry was therefore left in the hands of Yanmar.

However, in-house development and manufacture required an enormous amount of capital, and it took three years before a “go” decision was finally made. It was not until November 1966 that concrete plans, such as plant sites, production models, and the scale of production, began to be discussed.

In September of the following year, the Kinomoto Plant was constructed in Kinomoto-cho, Ika-gun, Shiga Prefecture (present-day Kinomoto-cho, Nagahama) for the mass production of tractors. It was the first full-scale farm equipment manufacturing plant for the company.

While the plant was being constructed, Yanmar’s engineering staff worked laboriously building prototype tractors, conducting endurance tests, and developing engines. The fruit of their efforts was the YM273, the company’s first diesel tractor.

Since tractor engines need more power than tiller engines, “*tate-sui*,” the vertical water-cooled multi-cylinder engine, was developed specifically for tractors to replace “*yokosui*,” the horizontal water-cooled single-cylinder diesel engine. In 1968, Yanmar began production of its prototype, 2W90 (20 hp), followed in 1970 by the high-speed model 2TR22 (22 hp). In addition, Kanzaki Kokyukoki Mfg. Co., Ltd. which developed transmissions for tractors, acquired a plant site in Santo-cho, Sakata-gun, Shiga Prefecture (present-day Maibara, Shiga Prefecture) and completed the Ibuki Plant in July 1970 in order to increase output.

By January 1968 when the production of YM273 tractors began at the company, competitors already had their tractors on the market. What they lost by being late in entering the market, they had to make up for with quality. In August of that year, tractor-related engineering staff at the research & development center was summoned to the Kinomoto Plant to strengthen its development team. But it was not easy to catch up with manufacturers who had taken the lead, and during the first five years until 1972, their market share stayed at about 10%.



Kinomoto Plant (1967)



A YM273 tractor in operation



Assembling transmissions for tractors





A John Deere tractor

Tractors developed at the Kinomoto Plant were in the range of 16–26 hp. However, Yanmar Agricultural Equipment wanted a full line-up of tractors including middle and large-size products of over 50 hp, and began to seek partnerships with overseas manufacturers. Negotiations moved forward with the US-based Deere & Company, the world’s largest farm equipment manufacturer, and in May 1972, Yanmar Agricultural Equipment entered into an import and sales agreement for large tractors with John Deere Intercontinental Co., Ltd. in charge of exports for Deere.

### The road to the mechanization of rice production

For farmers, rice planting and reaping are especially hard labor, and mechanization of these processes was a long-time dream. The demand grew even stronger as more men, the breadwinners, went to cities to work as seasonal migrant laborers, leaving farm work to those left behind. This phenomenon was called *san-chan nogyo* (three-*chan* agriculture, *chan* being an affectionate suffix added to names and titles of family and friends), meaning that farm work was done by *ji-chan* (grandfather), *ba-chan* (grandmother), and *ka-chan* (mother).

In the latter half of the 1960s, combine harvesters and rice transplanters appeared on the agricultural equipment market, and the mechanization of rice cultivation was encouraged. These, along with the tractor, were called the “three sacred regalia” of farm equipment, and they quickly became widespread, because farmers had become financially more secure as the economy grew, and were ready to purchase high-performance agricultural machinery.

It goes without saying that Yanmar Agricultural Equipment was also developing combine harvesters and rice transplanters. However, there were many obstacles before these products were actually commercialized.

#### Reaper-binder and combine harvester

While major farm equipment makers were competing in the research and development of the reaper-binder, which can be said to be the forerunner of the combine harvester, Yanmar Agricultural Equipment was still busy developing the tiller. Not having enough time for binders, they gave up on in-house development and instead entered into a sales tie-up with Minoru Industrial Co., Ltd.



A power reaper with planetary gearbox

of Okayama Prefecture and launched power reapers with planetary gearbox in January 1965.

However, not long after that, reapers equipped with a device to bind cut stalks made their appearance. Since their reapers did not have a binding device, the engineering staff had to totally remodel their machine, and in July 1968, lagging behind competitors, they launched a two-row reciprocating reaper-binder.

But the following year, the rice crops were bad due to unseasonable weather, and errors such as misbinding and incomplete reaping of stalks were made by farm equipment, not only Yanmar Agricultural Equipment’s but also all the other companies in the industry. The engineering staff was again forced to modify functions. They worked day and night searching for ways to enable the reaper to flexibly handle poor growth of rice, and in April 1970, launched a one-row reaper-binder. Later when the YB101TS one-wheeled one-row reaper-binder was introduced in 1975, it received high acclaim, for it could be used in very wet rice fields where reapers could not previously be used.

Meanwhile, the development of the combine harvester began in June 1968, and in May of the following year, the TC500 walk-behind two-row combine equipped with their diesel engine was launched. Until then, combines were powered by gasoline engines, but after the introduction of the TC500, diesel engines became the standard. However, due to inferior rice harvesting, just like the reapers, the engineering staff had to hurriedly modify the combine from its first year on the market.

In 1970, the TC450 combine, capable of reaping rice no matter how dense or sparse, was introduced, followed in March 1972 by the TC750 riding two-row reaper. The TC750, which was later praised as a masterpiece of equipment, was equipped with an axial flow thresher made specifically for combine harvesters that made it possible to thoroughly thresh rice without damaging the grains. The TC750 was a revolutionary product that started the golden age of combine harvesters.

#### Rice transplanter

Yanmar Agricultural Equipment, which had fallen behind competitors in developing the reaper-binder and the combine harvester, was determined to take the lead in rice transplanters. It entered into a tie-up with Daikin Industries, Ltd. which was a step ahead



The YB101TS reaper-binder



The TC500 combine



The TC750 combine

in the development of the rice transplanter, and in May 1967, began selling the string seedling-type rice transplanter (engine-powered rice transplanter) developed by Daikin Industries. Due in part to the “rice planting classes” held in various locations in Japan encouraging mechanization, 38,700 units were sold in the first three years after its launch, a market share of 57%. The company had taken the lead.

However, this lead was soon lost when the mat-type rice transplanter, which required less labor, was introduced. As with the binder, engineers were forced to start anew.

In February 1972, Daikin Industries and Kanzaki Kokyukoki together began developing a mat-type rice transplanter, paying special attention to the planting forks, which greatly affected the machine’s efficiency. When the “block planting type,” which allowed even, one-by-one planting of seedlings without breaking off the soil around the root, was developed and used on the transplanter, it became exceedingly popular. Farmers praised it, claiming that “seedlings rooted well” and that it “could be used to plant both young and medium seedlings.”

As described, there was a series of troubles and failures during the early stages of their efforts at the mechanization of rice cultivation. However, these experiences provided invaluable lessons, and the staff in research and development continued to accumulate expertise and develop their engineering skills through continual trial and error.

With the widespread use of high performance machinery, such as tractors, combines, and rice transplanters, mechanization of farm work advanced quickly. At the same time, better fertilizers, agrochemicals, and cultivation techniques were developed, greatly improving agricultural productivity. Working hours for rice cultivation for ten ares of agricultural land were shortened from 173 hours in 1960 by one-third to 118 hours, in 1970.

On the other hand, surplus rice in government storage exceeded 5.5 million tons in 1969 due to good harvests that continued for several years and a decrease in rice consumption caused by the diversification of eating habits. In 1970, the first policy of reducing acreage under cultivation was introduced. This policy aimed at reducing rice production by 1.39 million tons (about 10%) per year by offering subsidies to rice farmers who agreed to leave land fallow or grow other produce in place of rice. This was the first time that such a

measure was taken in the long history of rice cultivation in Japan. There was strong opposition from every direction, but most of the farmers reluctantly accepted the policy, and the sales of Yanmar Agricultural Equipment fell below that of the previous year for the first time since its establishment. Even so, tractors, combines and rice transplanters were becoming widespread, and because the price of rice rose in 1972 for the first time in four years, business quickly recovered.

### Entry into the fiberglass boat business

Diesel-powered fishing boats, which counted 43,000 in 1958, increased in the next ten years almost fivefold to 200,000. Market share for the engines was approximately 70%, but from the latter 1960s, dark clouds began to loom over the business.

One of the reasons was the decline in the demand for fishing boats as the result of tighter restrictions on catch limits and fishing boat horsepower. Another reason was the intensified competition due to market entry by companies in different industries. In order to make coastal fishing boats larger and faster, engines with higher output became necessary, and automobile and other manufacturers had begun to enter the market. Lightweight automobile diesel engines with high rotation speed modified for use in fishing boats became a major threat to Yanmar.

Around 1965, Yanmar had plans to expand the boat business by introducing high-speed engines of 7–280 hp and by manufacturing fishing boats to make up for the decline in the demand for engines. This was a time when fiberglass-reinforced plastic (FRP) boats were rare, and though there were some pleasure crafts, most of the coastal fishing boats were made of wood. However because of its lightness, extreme durability, and quick acceleration, FRP was beginning to gain attention as a new material for fishing boats.

However, experienced and skilled shipbuilders were gradually decreasing in number. Though far more expensive than a wooden boat, an FRP boat that could be built in a short period of time had great potential.

At the time, 70% of diesel-powered fishing boats under 5 tons were using Yanmar engines. It was very likely that these boats would eventually be replaced by FRP boats. What if Yanmar could



Rice transplanter with planting forks



A block-type planting fork

sell not only engines but also fishing boats and instruments to existing customers? That could be big business for the company.

The only problem was that the company had no knowledge of shipbuilding or FRP and had to start everything from scratch. In June 1966, *Kanzaki-maru*, a wooden test ship built at a shipyard in Akashi, Hyogo Prefecture, was launched. The main purpose was to study what ship shape had low resistance, and to investigate the relationship between the engine output and the engine speed using a real boat.

Later, inviting outside specialists, Yanmar began full-scale research and study in FRP technology and learned shipbuilding skills. The company also entered into a wide-ranging business alliance with Yamaha Motor Co., Ltd. which was at the time the top manufacturer of FRP boats, and gained a foothold in the new market.

Then in January 1972, the company established Yanmar Shipbuilding & Engineering Co., Ltd. in Ushimado, Oku-gun, Okayama Prefecture (present-day Ushimado-cho, Setouchi, Okayama Prefecture), and began operations in the FRP boat business. The reason for putting the headquarters in Ushimado-cho was so they could capture the big market around the Seto Inland Sea.

Fishing boats come in various shapes and sizes. It is even said that ship shapes differ from fishing port to fishing port. Yanmar Shipbuilding, after due deliberation, decided to make four types of ships:

- pole-and-line-fishing boats (targeted for all of Japan)
- trawl boats (targeted for Seto Inland Sea)
- trolling boats (targeted for Wakayama Prefecture)
- pleasure fishing boats (targeted for all of Japan)

The first Yanmar FRP boat, A-250 (pole-and-line-fishing boat targeted for all of Japan) was completed in October 1972.

### Formation of sales companies nationwide and measures for the agricultural cooperatives sales channel

Shifting from a manufacturer specializing in engines to a comprehensive machinery manufacturer meant the company would be handling more types of products, which in turn meant that they would need larger dealers with greater capital strength. As a consequence, they

began to see cases in which the sales system, which consisted mainly of privately owned dealers, could not adequately handle the business. The first to make a move was Yanmar Agricultural Equipment.

In 1960, the number of tillers owned by farm households was 520,000, but in the next five years, the number increased to 3 million. This fast-paced penetration and expansion caused fierce sales competition among the manufacturers and drove front-running companies to bring dealers under their umbrella, in other words, make them into sales companies that sold and serviced only their products.

Yanmar dealers were originally small in scale, and the increased number of products they had to handle and the high unit prices were causing shortages in capital and employees in their shops. The main selling point of equipment was high-efficiency, but the dealers could not keep up with the fast-moving technology, which caused problems both in sales and services.

Even before Yanmar Agricultural Equipment was established, the company had held management seminars for dealers, and attempted to change their style of management to one based on “numbers” rather than “gut feelings.” However, dealers were still apprehensive, and the move toward the establishment of sales companies grew stronger every day.

In response, Yanmar Agricultural Equipment took an original method of establishing “joint sales agents” by combining several local dealers. Aiming for a loose union that would enable their coexistence and co-prosperity, it was decided that the company and Yanmar Agricultural Equipment would provide capital participation to these companies, but allow each to maintain its independence.

First, six dealers in the southwest block of Okayama Prefecture got together. After each presented their management issues, they held intensive discussions concerning what might be gained by joining together as a company. In March 1963, the first joint sales agent, Kibi Yanmar Co., Ltd. was established. The company gained attention as a new business model, and similar sales companies were set up one after another throughout Japan.

Aside from the dealers, Yanmar Agricultural Equipment had another channel to sell their product via agricultural cooperatives.

Since the same products were sold through both channels, there was strong opposition from some in the commercial sales channel. This was because cooperatives had many advantages in selling the products. For example, the money for low-interest loans to farmers



Yanmar Shipbuilding & Engineering



The A-250 boat



Kibi Yanmar (1963)



came from the cooperatives, meaning that farmers who needed loans for their equipment could only buy through them.

To solve this situation, Yanmar Agricultural Equipment established Fuji Noki Co., Ltd. (trans. *Fuji Agricultural Equipment Co., Ltd.*) in December 1966 to handle sales and services specifically to cooperatives. Yanmar Agricultural Equipment separated sales by channels in an attempt to ease the resistance of the commercial channel. Fuji Noki steadily grew as agricultural mechanization advanced, but after fulfilling its expected role as an adjuster of the two sales channels, its business was transferred to Yanmar Agricultural Equipment and was closed in July 1971.

Yanmar Agricultural Equipment was also one of the first to enter the farm facilities business targeting cooperatives. This included the construction of large-scale facilities for seedling and grain drying, storage, and distribution of agricultural products. In September 1963, Yanmar Agricultural Equipment developed the first hulling plant in the industry for Asaseishi Agricultural Cooperative in Aomori Prefecture. With this as a turning point, they began to develop and construct rice seedling facilities, rice centers (large-scale cooperative grain drying facilities), grain silos (large-scale cooperative grain drying and storage facilities), and horticulture facilities, taking the initiative in systemizing agriculture.

Meanwhile in the marine business, sales companies were also established all over Japan to strengthen sales. However, they were structured differently from those of Yanmar Agricultural Equipment. Called “regional Yanmar distributors,” they were set up as a base from which to serve areas not covered by dealers. They were financed by Yanmar, and sales were made to customers directly by Yanmar.

The idea for “regional Yanmar distributors” was formulated at an early time. The first regional Yanmar distributor, Aomori Yanmar Distribution Co., Ltd. was established in October 1969 in Aomori Prefecture, but its forerunner, Seinan Yanmar Hanbai Co., Ltd. (trans. *Seinan Yanmar Sales Co., Ltd.*), was actually founded in September 1966 in Hachinohe, Aomori Prefecture.

Subsequently, other sales companies were established in various places in Japan, including Ehime Yanmar Co., Ltd. (Matsuyama, Ehime Prefecture) and Nippo Yanmar Co., Ltd. (Oita, Oita Prefecture). Initially, they handled mainly marine business, but when the construction equipment business took off, they also began to conduct business in land-based products.



A hulling plant



A grain silo

There is an organization similar to agricultural cooperatives in the marine business, the fisheries cooperatives. Its central organization, the National Federation of Fisheries Cooperative Associations was the lender of capital loans and the contact for subsidies for the fishing business. Yanmar had been selling to prefectural federations and individual fisheries cooperatives, but they persisted in negotiations with the National Federation to consolidate and place their orders with Yanmar through a single channel, the fisheries cooperatives association. In April 1970, a sales agreement stating that orders from fisheries cooperatives and independent fisheries cooperatives would be limited to the companies' products was signed. In this way, marine diesel engine expanded its market share.

## Strengthening of the production system and modernization of facilities

As agricultural machinery became more efficient, two types of engines, installed and stationary, came to be used, and more and more demand was placed on mobile engines that were high in performance and light in weight. The most effective way to make engines lighter was to use aluminum material which was much lighter than iron. The die-casting technology of aluminum alloys had advanced considerably along with the period of economic growth, and the company gave attention to this point.

In December 1964, they constructed the Yamamoto Plant in Kohoku-cho, Higashi-Azai-gun, Shiga Prefecture (present-day Kohoku-cho, Nagahama, Shiga Prefecture) and began producing special light alloy die-cast components. This plant, along with the Kinomoto Plant, which manufactured tractors, and the rural plants, created a large production group in the Kohoku-cho area centered around the Nagahama Plant.

Meanwhile, the demand for cast parts also increased suddenly, and it became a matter of urgency for the Juso Plant, their cast-metal components manufacturer, to step up production. However, the Juso Plant was located on the outskirts of Osaka, and they could not hope to expand those facilities when they considered the effect it would have on the surrounding environment.

Yanmar therefore decided to construct a brand new plant specifically for cast parts equipped with cutting edge production lines.



Yamamoto Plant (1964)



A die-cast plant



Foundry operations at Koga Precise Foundry



NC machine tools in operation



Engine test lines

In January 1970, Koga Precise Foundry Co., Ltd. (present-day Yanmar Casting Technology, Koga Division) was established as the new main production base of casting products (Kosei-cho, Koka-gun, Shiga Prefecture; present-day Kojibukuro, Konan, Shiga Prefecture). Production lines were moved to the new plant from both Kanzaki and Juso Plants, and operations were merged. The Juso Plant was closed, and its employees were transferred to Koga Precise Foundry and the Kanzaki Plant.

The Kanzaki Plant, which thereafter specialized in large-size engines, embarked on an effort to modernize their systems with automated facilities. Their plan was to use numerically controlled (NC) machine tools to process components.

NC machine tools could be automated by computer control. They were adopted by manufacturing industries, especially smokestack industries, which faced acute labor shortage in the latter half of the rapid economic growth period. The Kanzaki Plant introduced NC lathes in 1962, and machine shops (machines with automatic tool changers) in 1968, and actively proceeded to automate machine work.

Automation increased production capacity as well as improved quality. In 1965, the plant was certified by the Ministry of Transport (present-day Ministry of Land, Infrastructure, Transport and Tourism) as an approved manufacturer under the Ship Safety Law. Recognized for excellence in quality control and production technology, it also received certification as an approved manufacturer from the ship classification society, Class NK, in July 1968. The same year, annual production of large engines surpassed 1,000 units.

In July 1970, when each plant was attempting to strengthen its production system, a major change in organizational structure was made. The Production Division was divided into two, the Shiga Zone Production Office and the Hanshin Zone Production Office. Regional plants were put under the management of these two offices to leverage collective strength and to promote initiative and constructive planning. With the introduction of the new production office system, the Kanzaki Plant was renamed Amagasaki Plant.

## Aiming for “Global Yanmar”

Ever since receiving a crushing blow when trade with India was suspended, the company had refrained from actively seeking business overseas. Blinded by the size of orders from India, it had not made sufficient efforts to develop the domestic market, causing it to lag behind its competitors. The company did not want to make the same mistake again. Even during the rapid economic growth period when many companies expanded their overseas business, it only exported products mainly to Southeast Asian countries as war reparations from the Japanese government or through trading companies.

However, President Yamaoka declared in his inauguration speech that his aim was to make a “global Yanmar.” He did not approve of Yanmar hesitating to advance into overseas markets, remaining stuck in the past. He set a goal of increasing export sales, which had been fluctuating at 13% of gross sales, to 20%. He proposed a shift to a new business model, suggesting that instead of depending on trading companies to distribute their products, they should continually increase sales by establishing local representative offices and by educating these representatives.

It was a bold change of direction, but the Overseas Trading Department responded by increasing the number of export countries from 90 and several in 1964 to more than 110 in 1967. In only three years, its products came to account for 64% of all Japanese diesel engines exported.

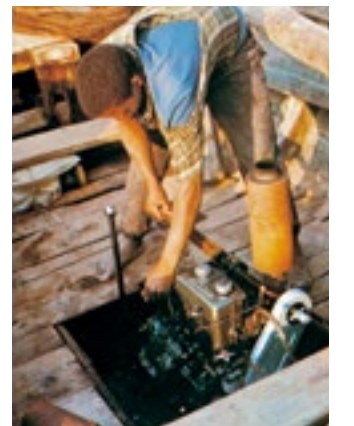
A boat equipped with a *yokosui* engine (Thailand)A pump equipped with a *yokosui* engine (UAE)

A marine engine in Africa



Exports increased to approximately 5.3 billion yen, more than threefold the amount of export to India during the peak period.

In the latter 1960s, Southeast Asian countries began to implement economic policies restricting imports in order to nurture domestic industries. The company therefore changed strategies and turned to the possibility of local production, and in August 1970, made capital participation in Yanmar (Malaysia) Sdn. Bhd. in Kuala Lumpur, Malaysia. It was a joint venture with a local company, but it was named Yanmar, and it became Yanmar's first local production company in Southeast Asia. Diesel engines were manufactured under their technical guidance using components supplied by Yanmar.

In March 1972, P.T. Yanmar Diesel Indonesia was established as a joint venture in Jakarta. It also began manufacturing small diesel engines.

As for industrially advanced countries in Europe, the company waited until after they had developed and won recognition in the markets of the surrounding countries in the Middle East and northern Africa before entering the European markets.

At the time, most of the small engines used in Europe were air-cooled gasoline engines. Since people had little familiarity with water-cooled diesel engines, the company test launched the world's smallest air-cooled diesel engine that they developed in 1959 to see how the market would respond. As a result, the company's technology was rated highly, and Yanmar became more and more well known.

Later, research conducted by the Overseas Trading Department indicated that it was highly likely that Yanmar's small marine diesel engines would be accepted in the European pleasure boat market. The company developed small diesel engines for yachts for the Western market, and in February 1971, fulfilled its long-time desire to export to the West.



Yanmar Diesel Indonesia (1972)

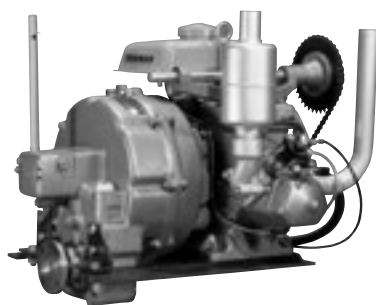

A small diesel engine for yachts

## Overcoming the Era of Low Economic Growth by Energy Conservation and Waste Elimination

# 1973-1984







The 1973 oil crisis



Trade friction between Japan and the importing countries

#### HISTORICAL BACKGROUND

The 1973 oil crisis put an abrupt stop to the steady growth of the Japanese economy that had continued to expand following the Second World War. The trigger of the oil crisis was the Yom Kippur War (the 1973 Arab-Israeli War) that began in October causing a sudden increase in the price and a decrease in the production of crude oil.

At the time, Japan depended on oil for more than 70% of its energy supply and imported most of it from the Arab nations. Japan was hard hit, and the following year, experienced negative growth for the first time in postwar history. People's ways of thinking also changed dramatically, and the trend in Japan instantly shifted from "consumption is a virtue" to "economizing is a virtue."

In an era of deep depression and low economic growth, industries in Japan began to change the economic structure by adopting measures to conserve energy and natural resources and by implementing streamlined management. They made a transition from smokestack industries that depended on petroleum to more knowledge-intensive industries, such as computers and electronics. At the same time, they strengthened global competitiveness by increasing production efficiency.

Boosting the volume of exports, especially to Europe and North America, Japan increased its presence in the world as an economic power. However, this caused trade friction between Japan and the importing countries over a variety of products. Due to continuous pressure from the Western countries, Japanese manufacturers were forced into voluntary export restraint agreements in 1981 regarding automobiles, and in 1983 regarding video tape recorders.

## Development in rapid succession of energy-saving diesel engines

The 1973 oil crisis was a serious blow to Yanmar as well. However, President Tadao Yamaoka, stated as follows in the company's 1974 Business Management Policy. "That is all the more reason why we should make this a meaningful year, the start of a second history of Yanmar's development by making contributions to the nation through energy conservation." The company had upheld the fundamental principle "To conserve fuel is to serve mankind" for a long time. The unstable supply of crude oil, Japan's major energy source, was in a sense a chance for the company to prove its true worth.

Japan had already become one of the leading economic powers in the world, but that strength was based on the assumption that there would be a steady supply of cheap oil. When oil shortages began to occur, neon lights were turned off in cities, TV stations put a voluntary restraint on late-night television shows, and rumors about shortages led to panic and hoarding of toilet paper. The oil crisis taught the people that when an "assumed" ladder was removed, the affluence of Japan, which seemed firm as a rock, was actually quite precarious.

For Japan, a country with no natural resources, imported oil moved the country. Faced with an unprecedented energy crisis, it became even more critical to further improve Yanmar's already highly thermal-efficient, economical diesel engines, so that precious fuel could be used effectively without waste. Contributing to the conservation of energy and natural resources through products was a key component of the company's social responsibility and mission.

The first energy-saving product developed was the marine diesel engine. In the fishery industry, fuel represented a significant portion of the operating cost, and the rise in fuel prices directly affected business. Increasing fuel efficiency in engines was therefore a pressing issue. Two innovative technologies tremendously enhanced the combustion rate.

One was the fresh-water cooling system. This system circulates fresh water to cool the engine, and then cools the heated fresh water using seawater. Until that time, cold seawater was used for cooling engines, but that not only resulted in much heat loss, but also caused cracks and corrosion in cylinder heads. On the other hand, using fresh water, which could be kept at 70 to 80 degrees Cel-



Technology that makes the most of every drop of fuel



The 6KE-HT marine propulsion engine (400 hp), 1975

sus by a thermostat, prevented mechanical and cooling loss, and contributed greatly to reducing fuel consumption. Yanmar's first engine using this system, the 6KE-HT marine propulsion engine (400 hp), was completed in October 1975.

The other important technology that was developed was the direct injection type combustion chamber. Originally, gasoline was partially combusted in a pre-combustion chamber, then injected into the cylinders for full combustion. This was changed to a system in which fuel could be injected directly into the pistons without using the pre-combustion chamber. This shortened combustion time, and because it did away with the loop loss between the pre-combustion chamber and the main combustion chamber, the combustion rate increased by 10 to 15%.

This system was already in use in middle and large-size engines, but in small engines, there were many problems, one being that fuel injected did not mix well enough with air, because it collided too soon with the cylinder walls. It was difficult, but by altering the shape of the combustion chamber and developing high-pressure fuel pumps, the engineering staff finally managed, after repeated trial and error, to bring the system to the stage of practical application. In May 1977, a direct fuel injection engine with a fresh-water cooling system was launched as the 6HA marine propulsion engine (200 hp).

In the long history of Yanmar's research and development of diesel engines, the direct fuel injection technology was a milestone. The technology spread rapidly and was used widely even in non-marine small diesel engines.

Meanwhile, the demand for large engines declined sharply after the oil crisis, when the shipbuilding and marine transport industries fell into a serious recession. The primary factor for the recession was the high price of crude oil, and the demand from the industries for more economical marine engines became stronger. In response, the company developed energy-saving engines including the S185 (550–600 hp) and the T260 (1,400–1,500 hp).

In parallel with energy-saving, the company also engaged in the development of engines capable of using low-quality fuel. As refining technology advanced to increase yields of good-quality fuels from crude oil, residual oil, which is the basic material for boat fuel, tended to become more and more inferior. Low-quality oil was high in viscosity, had poor combustibility, and contained a lot of impurities that led to engine trouble.



The 6HA marine propulsion engine (200 hp), 1977

In June 1978, Yanmar launched the 6ZL-UT (1,300 hp), the world's first medium-speed 4-cycle marine auxiliary engine capable of using C heavy oil with a viscosity rate of 1,500 seconds. Heavy oil is classified by Japanese Industrial Standards (JIS) depending on its quality into three grades, A, B, and C, from good to bad. The number of seconds indicates the time required for a certain amount of oil to pass through a narrow pipe (viscosity). C heavy oil at 1,500 seconds is therefore a low-quality thick oil of high viscosity. However, it is inexpensive, and using this as fuel led to a massive reduction in fuel cost.

Yanmar continued to expand the range of oil that could be used as fuel, and in March 1985, surprised the industry with the T260L-EX engine (1,500 hp) capable of using low-quality fuel with a viscosity rate of 7,000 seconds.

The company also restarted the development of air-cooled diesel engines after a long suspension to bring to the market diesel engines that were more economical than the gasoline engines used in small agricultural machinery and generators.

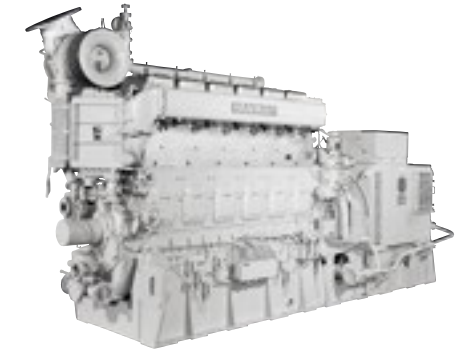

The 6ZL-UT (1,300 hp), 1978

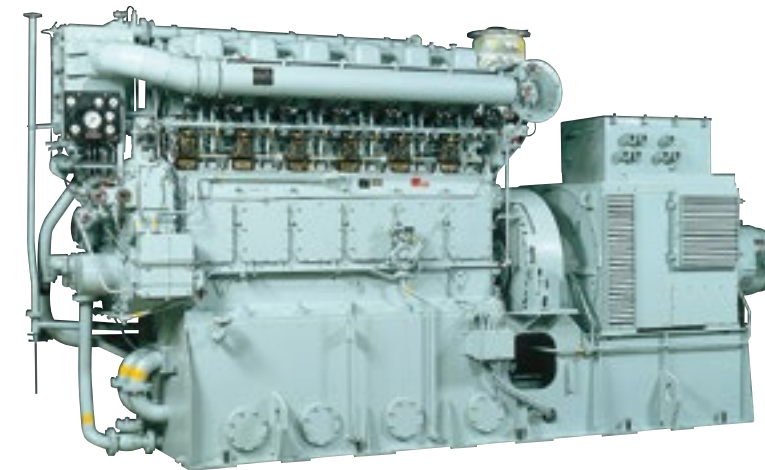

The T260L-EX engine (1,500 hp), 1985



### Comparison of Engine Form

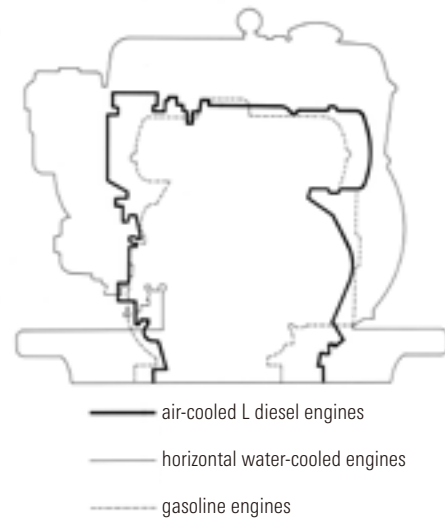

Air-cooled L diesel engine series (4-9 hp), 1983



A generator with an air-cooled diesel engine

The L air-cooled diesel engine series (4-9 hp) completed in 1983 became the world's smallest and lightest model equipped with the newly developed ultra-small bushless fuel pump and mini nozzles. The engine, with energy-saving and long-time operation capabilities far superior to the gasoline engine, was well received and became a hit product that sold out repeatedly. Many other hit products using this engine were launched, including generators, lighting towers, and cultivators.

Air-cooled diesel engines demonstrated their capability especially in generators for roadwork at night. Gasoline generators at the time operated for 3 to 4 hours at the most on a full tank of fuel, but diesel engines could run continuously for 12 to 13 hours. This meant that it was possible to work throughout the night without replenishing fuel. Besides, diesel was a more familiar fuel than gasoline at sites where construction equipment was used. The engine was so easy to use at these sites, it took over the market virtually overnight.

### The rise of the "tatesui," vertical water-cooled engine

Economical efficiency was not all that was demanded of small engines in and after the late 1970s.

At the top of the list was high output. As small construction equipment and tractors became widespread, and demands of domestic and international OEM grew, engines with larger horsepower became necessary. For many years, it was the "yokosui," horizontal water-cooled engines, that had supported not only Yanmar's small-engine business but the company as a whole. However, as domestic demand declined with the changing times, Yanmar began to shift the focus to exporting them.

As to the "tatesui," vertical water-cooled diesel engine, it had already been developed for mounting on tractors, but it became necessary to make it more versatile so it could be used with a variety of machinery. In April 1976, the production of the T series with 2 and 3 cylinders (12.5-31 hp) began, and in February 1979, the TH series began mainly using 3 cylinders (12.5-42 hp).

In August 1983, an epoch-making *tatesui* engine, the TN series (11-100 hp), was developed.

What was so revolutionary was that the combustion system was



The TN series (11-100 hp), 1983

changed from the previous auxiliary chamber type to the direct-injection type. The direct-injection type system had been built in 1977 for marine engines, but it was extremely difficult to apply to small vertical water-cooled engines with 75mm diameter cylinders. However, due to the development of the CL pump, which housed the fuel pump and the governor together, Japan's first vertical water-cooled direct-injection engine was developed, reducing fuel consumption by about 20% compared to conventional engines. The TN series, which was also 15 to 20% lighter in weight and had a high revolution of 3,600 rpm at normal output expanded its purpose as a general industrial engine. The basic design of this series is still used today in Yanmar's *tatesui* engines. After this, *tatesui* engines became the main product of the small engine business.



The CL pump

### Creation and growth of the compact construction equipment market

In the industrial-use market, Yanmar had started selling products such as generators and welders in sets with small diesel engines (horizontal water-cooled) from the late 1950s, but just as in the agricultural-use and marine-use market, the company was continuously on the lookout for machinery that would lead to the expansion of engine sales.



The company set its eyes on the construction industry, which was booming during the rapid economic growth. At the construction sites of large public works projects, which were at the peak of their golden age, large machinery such as bulldozers were already busy at work. However small-scale earth excavation and ground leveling were still done manually, and working efficiency improvement and labor reduction were major issues of concern.

Yanmar decided to focus on compact construction equipment with a small turning radius that was compatible with the output range of *yokosui* engines. In October 1965, the company launched the HD5 walk-behind dozer, a machine developed by an affiliated company, Takeshita Tekko, based on power tillers, to collect and remove earth and level ground. It was sold in the Kitakyushu area for use in coal mines, but actually, the product was still in a preliminary stage.

Yanmar continued to search for products in which to install small diesel engines, and in 1968, completed the YNB300 wheeled mini excavator. The company also launched the YNB400 crawler mini excavator, as well as the YFW500 rubber-tracked crawler carrier for transporting construction materials and sediments on soft and uneven ground. However, they were not sufficiently efficient and required significant improvements.

If Yanmar was serious about going into this business, it could not leave the development of the machines to other companies. In July 1971, Yanmar established the Machinery Division within the Sales Department covering the industrial-use market and embarked upon full-scale product development. In April of the following year, Yanmar launched the YB600C crawler mini excavator. After thorough reexamination of the previous model, many improvements were made including better stability during excavation.

The YB600C won instant popularity with water and gas piping businesses, for it not only dug gutters with ease, but could dig close to walls, even in tight spaces. This high performance backhoe, answering every need of users, became known through its attention-grabbing advertising slogan, “the wall-edge magician.” A pioneer of mass-produced compact construction equipment, the mini excavator is, to this day, a major product of Yanmar’s construction equipment business.

In December 1973, the company established the Construction Equipment Development Department and began to plan and develop original products more suited to the market demand.



The HD5 walk-behind dozer (1965)



The YNB300 wheel mini excavator



The YB600C crawler mini excavator (1972)

While large national projects decreased with the end of the period of rapid economic growth, small-scale municipal infrastructure projects, such as water supply, sewage, and parks increased, and the demand grew for compact construction equipment that could be operated in small spaces. Furthermore, the housing starts, which had decreased rapidly after the first oil crisis, improved in 1976, pushing the construction equipment business forward to become the third business pillar of Yanmar, following the agricultural machinery and the marine businesses.

The foundation of this successful business was the long-term seller, the YB1200 mini excavator, which was launched in August 1975. Not only could it turn 360 degrees so that the user could get on and off from the right or the left side, it was also installed with a vertical water-cooled engine for easy starting in cold weather. It was also quiet and had good suspension. Its high performance, user-friendliness, and construction site adaptability gained wide support, so it earned the reputation “If you want a mini, get Yanmar’s.”

Yanmar also launched other products that reflected the market needs, including the YFW1000D and 2000D crawler carriers equipped with a dumping mechanism, and the Y30W, Japan’s first four-wheel-drive loader with independent drive for right and left wheels, until the company had a product lineup capable of handling all the basic tasks at construction sites such as digging, loading and carrying.

The company being a pioneer in the business, the compact construction equipment enjoyed market dominance and made a leap



The YB1200 mini excavator (1975)



The YFW1000D crawler carrier



The Y30W wheel loader



A construction equipment convention with rental agents and overseas dealers (1984)

in sales from 7.9 billion yen in 1975 to 21.8 billion yen in 1980. But naturally, Yanmar's competitors were not going to just sit back and look on with envy. It was not long before large construction equipment manufacturers made their entrance into the market one after another. By 1978, the number of makers totaled 25, and a heated competition for survival began.

Simultaneously, a new business category, the "rental business," appeared in the construction equipment market. More and more companies were streamlining their operations and becoming increasingly cost-conscious. The civil engineering industry was no exception. Work could not be done without construction equipment, and yet the purchase price and operating costs of machinery were huge burdens.

However, by leasing machinery, construction companies could use whatever they needed for as long as they wanted. What's more, they did not have to worry about securing a storage place or about maintenance. Leasing machines was also advantageous because rental fees could be included in operating expenses. In addition, while in the past owning machinery raised the rating of corporations bidding for projects, not owning machines became an advantage after more significance came to be placed on a company's management rating.

Yanmar predicted that this new business category would grow to become a big market in the near future, and leading the way, the company began to actively network with leasing agencies from around 1977. As expected, the use of rental construction equipment became widespread in a few years. In particular, compact construction equipment that could be transported on two-ton trucks gained immense popularity. Yanmar subsequently began to develop products specifically for rental purposes and rapidly increased the proportions of sales.

### Waste elimination activities and the introduction of a new production system

While Yanmar worked externally to develop energy-saving products, internally, it had to make efforts to eliminate waste, reduce costs, and build a strong, recession-proof corporate culture.

The company could not simply raise the prices of the products

to offset increases in production costs. Yet, in order to protect the trust in the brand, Yanmar could not lower the quality of products. "Elimination of waste" was therefore a necessary strategy for continuing sound operation in the severe business environment, and President Yamaoka was determined to see it through.

President Yamaoka hammered out measures to achieve "quality and cost management" in the company's 1975 Business Management Policy and set a goal of reducing gross cost uniformly by 10%. His basic stance was to eliminate invisible waste as well, including stereotyped systems and antiquated ideas.

Thus, the whole company became involved in waste-elimination activities. In production, the Shiga Production Branch and the Hanshin Diesel Division (established in 1974 by consolidating the Hanshin Production Branch and the main office for special dealers). The Large Product Sales Division actively initiated "waste-elimination activities" and the "M0 (Muda Zero, trans. *Zero Waste*) Operation" respectively.

### Shiga Production Branch

The core of the Shiga Production Branch was the "Toyota Production System." Toyota Motor Co., Ltd. (currently Toyota Motor Corporation) had quickly recovered business after the first oil crisis while other automobile makers were still floundering and had captured the attention of the industry.



President Yamaoka (left) with Vice President Taiichi Ohno of Toyota Motor



The “Toyota Production System” is also called “*Kanban Hoshiki*” (Just In Time) because they used tags called “*kanban*” in the process of production management. It is a system of supplying as many units of whatever as required, a mechanism that does not generate useless stock or works-in-process. To be more specific, work was scheduled backwards from the last process to the first. Components required for a process were taken from the former process, and the former process would only produce enough to replace what was taken. This method allowed plants to produce a wide variety of products in small quantities.

This was an ideal production system for the Nagahama Plant, where the variety of models produced increased year by year, resulting in high overhead cost because a larger inventory of products and parts had to be maintained. A project team was promptly set up in the President’s Office, and seeking direct guidance from Toyota, they began full-fledged investigation and research.

Of course, no matter how wonderful a system, it does not succeed just because it is introduced. There were other issues Yanmar had to consider, such as how smoothly the company could switch to the production of different models with the least time and manpower. How could Yanmar get affiliated companies supplying parts to agree to deliver however many parts the company needed at the required time? Seeking advice, the team came up with creative ideas and solved these problems one by one.

Yanmar called the “*Kanban Hoshiki*” the “*Kippu Hoshiki*” (Ticket



*Kippu* (Ticket)



An assembly line based on the *Kippu Hoshiki* (Ticket System) at the Nagahama Plant

System), and named the entire new production system the “Yanmar Production System.” In July 1976, the system was introduced on the gasoline engine line at the Nagahama Plant for a test run. Based on the results, they conducted further research, and in the summer of the following year, introduced it on the *yokosui* engine line, which was at the time Yanmar’s major product, the fuel-injection pump line at the Omori Plant, the fuel-injection valve line at the Nagahara Plant, and at the Yamamoto Plant.

Though at the start employees had to work through the night for consecutive days to smooth out glitches, the new system immediately produced results, including shortening lead time and reducing inventory. Seeing the positive results of their efforts, the awareness of employees and affiliated companies of the need to “eliminate waste” increased. This system was later applied to the *tatesui* engine line.

### Amagasaki Plant

At about the same time, the Amagasaki Plant also introduced a new production system in order to shorten delivery time and cut costs.

Large engines not only have different diameter cylinders but different specifications according to their intended purpose and operating conditions. They were ordered individually, so it was as if each engine shipped out was a unique model, different from any other. Unlike mass-produced products, it was difficult to streamline the production process.

In June 1976, they implemented a made-to-order production control system using computers called the “Production Control System by Practical Bill of Material (PCP).”

PCP was a consolidation of three systems: standardization of product specifications, production, and logistics. It oversaw everything from receiving orders to shipment of orders. By analyzing the “bills of materials,” the system devised ways to reduce waste in the design and production process.

After introducing the system, the usage rate of the same parts for different products increased, which in turn decreased the monetary value of parts in stock by half. The system also shortened production time by half, increased work speed, and saved manpower. Efforts were made to standardize product specification for large engines, and because it became possible to keep tabs on the cost of production for each product, the zeal among employees for cost-cutting became increasingly higher.



An assembly line (above) and shipping line (below) of engines equipped with PCP



Looking at the overall production organization, the total inventory decreased to 15.5 billion yen in September 1976 from 22.1 billion yen in the corresponding month of the previous year. Stock turnover period also decreased from 71 to 42 days. It was obvious that the system had achieved definite results in a short period of time. The related departments had worked as one toward a common goal with a strong awareness of what they wanted to achieve. It was a success based on teamwork cultivated through quality control activities.

In February 1977, the Amagasaki Plant, with its advanced production system, became the first plant in Japan to be certified as a facility for the mass production of internal combustion engines. This meant the plant was permitted to manufacture engines meeting the standards of the ship classification society, ClassNK, by confirming conformity on its own. This demonstrates how highly the Amagasaki Plant was evaluated regarding its facilities and technology, as well as its achievements in Japan and abroad.

The plant not only gained certification in Japan. It obtained certification as an authorized plant from the American Bureau of Shipping (ABS) in May 1978, the English Lloyd's Register (LR) in August 1978, and from the Det Norske Veritas (DNV), the Norwegian classification society, in October 1984. Certification can only be obtained after close inspection of documents and production facilities by the societies to make sure everything meets their rigorous standards. Authorization from these foreign marine classification societies therefore greatly increased the credibility of the plant, and laid the foundation for it to play an active role in the world market.

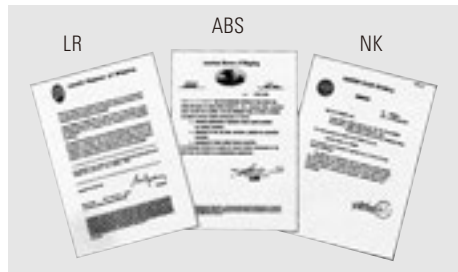

Certifications from British Lloyd's Register (LR), American Bureau of Shipping (ABS), and Class NK (NK)

### VA-VE activities and the "Suggestion System"

The Procurement Division, which was established in December 1974, implemented integrated purchasing and other strategies to strengthen purchasing management, and in order to achieve further cost reduction, promoted VA (value analysis)-VE (value engineering) activities.

VA-VE is a scientific method for analyzing products and production processes by evaluating their functions, and finding the optimal methods of reducing costs. It was introduced in full scale in May 1976, and Yanmar Group's production departments and affiliated companies together worked on issues such as purchasing materials at low prices and improving production methods. The

principles of VA-VE were later adopted by the product development departments and the administrative departments where they achieved good results.

As described, "waste elimination" activities were most often initiated by the production departments, and then extended to the rest of the company after positive results were seen. One such activity was the system of employee suggestions for improving business efficiency.

In August 1976, this "Suggestion System" was extended to the whole company, and the Suggestion Office was established in June 1978 so the system would be known throughout the company. The office periodically instituted campaigns to solicit suggestions on various subjects. The number of suggestions submitted for the 1980 topic, "Eliminating waste around us," exceeded 16,000.

The reason for the numerous suggestions submitted was the high rate of their actual implementation. That year, 75% of the suggestions were actually implemented. No matter how insignificant an idea might have seemed, the feeling that they could play a role in improving the company's business and working environment through their suggestions gave employees a strong sense of ownership. The "Suggestion System" took firm root as a business improvement activity within the Yanmar Group.



Suppliers presenting improvement cases



VA-VE activities at Nagahama Plant

## Introduction of a parts information management system

Due to the introduction of a new system in the production departments, inventory of parts was sharply reduced, but because of the diversification of products and the high-mix low-volume production, the variety of parts in stock continued to increase. In January 1978, products offered by the Yanmar Group numbered over 4,000. There were approximately 540,000 different parts used in these products, and the number continued to rise by over 10% every year.

It was difficult to share information on so many different parts among 7 companies, 17 plants, and 12 development sites in Japan. Each place of business was managing parts using a system of their own, but as a Group, there was much waste.

There had to be a way to centralize parts inventory information and streamline the flow of information. President Yamaoka instructed in the 1978 Business Management Policy that a system



A computer room where the “YSM System” was first introduced

be developed for parts information management that would realize a reduction in cost and sharing of parts. The company proceeded to standardize parts information and to systemize various operations, and in October of the following year, developed the “YSM (Yanmar Specifications Management) System.”

YSM was a pioneering system at the time that made full use of computers and communication network. A host computer managed parts information for the whole Yanmar Group, so that it was possible for all places of business to acquire information at any time on computer terminals connected by communication lines. All the departments, including development, engineering, production management, sales and service, became able to share and use standardized parts information, and this dramatically streamlined and improved the efficiency of the Group’s operations.

### Construction of a parts distribution center

At Yanmar Agricultural Equipment, where sales of tractors, combines, and rice transplanters were growing rapidly, a system for the speedy supply of service parts had become an issue. Since agricultural work was seasonal and concentrated in a few months of the year, it was necessary to ensure that service parts for agricultural machinery were supplied promptly and correctly. To that end, the Kanto Distribution Center (Sekijo-machi, Makabe-gun, Ibaraki Prefecture) was established as a distribution headquarters in December 1975.

At the same time, DOLS (Data Base On-Line System), a parts management system that linked the head office, plants, and the distribution center online, was introduced, so that shipping instructions could be given a few seconds after receipt of orders. The system also automatically ordered parts when inventory fell below a pre-determined level, thereby preventing out-of-stock conditions.

The only agricultural machinery maker at the time that had a distribution center was Yanmar Agricultural Equipment, meaning they had made this facility investments even before Yanmar, its parent company. Good business results was one of the reasons, but a bigger reason was the parts supply system at Deere & Company with whom they had a tie-up.

When Deere began importing tractors, Yanmar Agricultural Equipment noticed how much importance they placed on parts management

and the methods used for this, and eagerly studied the system. This experience led to the establishment of a distribution center, and later, other companies in the industry began to follow the example.

Distribution centers were subsequently opened in Kyushu (Chikugo, Fukuoka Prefecture), Tohoku (Furukawa, Miyagi Prefecture), Chugoku (Bizen, Okayama Prefecture), Hokkaido (Tomakomai) and Chubu (Yoro-cho, Yoro-gun, Gifu Prefecture) creating a network covering the entire country for supplying parts.

### Establishment of the Yanmar Kyoto Research and Development Center and progress of mechatronics technology

“Users will be demanding increasingly high quality, and the superiority or the inferiority of goods will be a decisive factor influencing the rise and fall of a company. I therefore want everyone to work with passion and commitment to develop original new products.”

This is an excerpt from the 1976 Business Management Policy. President Yamaoka had repeatedly called for a “cut in costs by eliminating waste,” but that alone could not ensure a company’s future. For a manufacturer, the only way to survive severe competition was to continuously bring original and valuable new products to market.

Reflecting the Business Management Policy that Yanmar had to sow seeds for the future despite the cost reduction programs already in place, Yanmar Kyoto Research and Development Center, equipped with cutting-edge facilities and equipment, was established in Oyamazaki-cho, Otokuni-gun, Kyoto Prefecture, near Mt. Tennozan in November 1977. Focusing on the future of engines and agricultural machinery, Yanmar had merged its research center with that of Yanmar Agricultural Equipment, and the new research center, staffed with 350 employees, began conducting research and development.

The new center not only engaged in basic research and product development, but also carried out research on reducing noise and vibration. In September 1981, it became the first in the industry to establish a control-technology research department (present-day Electronics Development Center) as an independent department for studying mechatronics.

“Mechatronics” was a new technology that became widespread after the 1970s. It links electronic technology such as LSI and micro-



Kanto Distribution Center (1975)



Order processing with DOLS



Yanmar Kyoto Research and Development Center (1977)



Mechatronics parts





New product seminars for sales agents (1981)



The TC1800 combine equipped with devices for automatic cutting-height control

computers with machines, allowing the machines to perform complicated operations with ease, as well as perform many new functions that could never have been realized by machines alone. This technology was originally used for posture control and other functions to improve the operating efficiency of farm machines. However, everyone in the industry was competing with each other in its research and development, and the technology progressed extremely rapidly.

In the tractor business, in 1981 Yanmar launched new products one after another, each equipped with advanced functions made possible only with electronic control, such as “auto-rotary,” which automatically controlled the tillage depth, and “UFO-matic,” which kept the machine horizontal when working in rice fields. These functions allowed practically anyone to do farm work, which till then depended on farmers’ intuition, with very simple operation.

Regarding combines, the TC2200 was launched in 1978. It was equipped with devices for automatic cutting-height control and automatic threshing depth control, as well as row-sensing automatic guidance control. The combine became a big hit not only in Japan but also in Taiwan.

Mechatronics was not used just in farm equipment. Its application was further extended to transmission control, fuel injection control, remote control for vessels, as well as products in new fields.

## Development of a “Dream Product”

The new products that President Yamaoka had in mind not only included products that could be sold in existing business fields. He was also thinking about bigger things, like products that could develop a whole new business.

Markets for Yanmar’s core businesses had already matured and the company could no longer hope for explosive growth. On the other hand, innovative technologies, such as electronics and mechatronics, were evolving at an incredible speed. With unconventional thinking and a challenging spirit, there was potential for developing a new product that would completely change traditional concepts. President Yamaoka declared that the maximum priority for the Yanmar Group on entering the 1980s was to develop a promising “dream product.”

At around this time, Japan formulated a national policy to secure a long-term stable supply of energy. In 1974, the “Sunshine Project” was

launched to develop new renewable energy sources, and in 1978, the “Moonlight Project” to develop technologies to improve efficiency of energy conversion and energy use, and to utilize unused energy.

### Cogeneration system

The demand of the time was energy-saving systems that enhanced energy efficiency. In response, Yanmar started the development of a cogeneration system that recovered exhaust heat from engines generating electricity and used it for air-conditioning and hot-water supply.

The thermal efficiency of diesel engines was normally 35%, and the rest was lost through heat dissipation, but with a cogeneration system, more than 75% of energy could be used effectively. If such a product could be realized, it would truly become a “dream product.”

The first such system was supplied to a tourist hotel in Yamanashi Prefecture in September 1979. Then in August 1983, Yanmar developed, in cooperation with the National Institute of Polar Research, an innovative cogeneration system for use at the Showa Station in Antarctica. Electric power had been insufficient at the Showa Station due to its expansion and the introduction of computers, and staff members there were leading an inconvenient life, even having to turn off the lights every time they wanted to toast a piece of bread.

When time came to transport the cogeneration system on the Japanese icebreaker *Shirase*, several Yanmar employees went along and stayed at the Showa Station for approximately 80 days from



Showa Station in Antarctica



Cogeneration system at the Showa Station in Antarctica



December 18 to install and conduct maintenance work on the system. Since power transmission began in March of the following year, it has operated satisfactorily, providing the people working hard in the Antarctic cold with well-lit comfortable rooms and a bath every day. The system, which supplied electricity, heat, and warm water, was also used to make fresh water by melting ice.

Yanmar's cogeneration system gained higher acclaim after its adoption by the Showa Station, and in 1985, it secured the top market share in the industry. In February of the same year, it was selected as the superior energy-saving machine of the year by the Japan Machinery Federation (JMF).

The system at Showa Station is still being used today, though with replaced parts and devices, and Yanmar staff are still dispatched to Antarctica every year. To date, a total of 32 employees have worked at the station.

### Gas heat pump air-conditioning system

Another energy-saving product that Yanmar began to develop was the gas heat pump (GHP) air-conditioning system that used a gas engine to drive the compressor.

As home air-conditioners became widespread and people became more concerned about electric power shortage in peak demand periods in the summertime, GHPs, which could cool rooms with one-tenth the electricity, gained attention. The summer of 1978 was extremely hot, and Japan experienced a tight supply of electric-

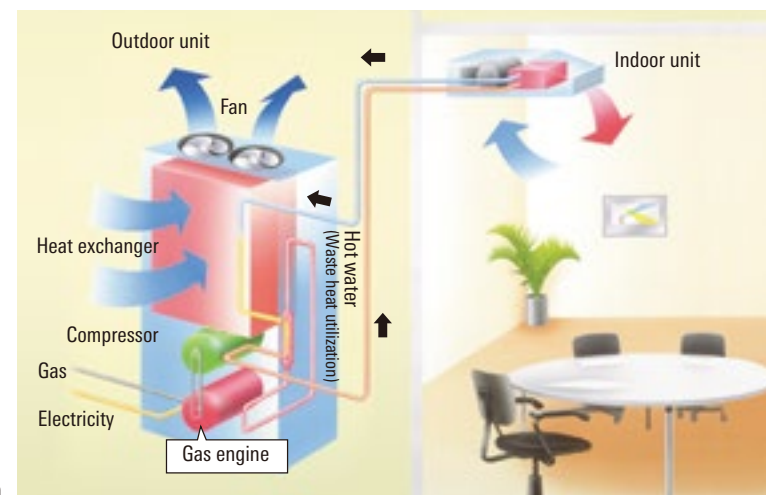

Gas heat pump (GHP) air-conditioning system

ity. The following year, the Ministry of International Trade and Industry (present-day Ministry of Economy, Trade and Industry), recognizing their value, decided to grant subsidies for the further research and development of GHPs.

In April 1981, three city gas companies and twelve manufacturers, including Yanmar, began to conduct full-scale research and development. Later, several companies withdrew judging that it would not be profitable, so by 1984 there were only the three gas companies and four manufacturers left to continue the development of a product for commercialization. Yanmar suffered many failures and frustrations as the company had no experience in the air-conditioning field, but the company made serious efforts toward a launch in 1987.

### Z drive system

In the FRP shipbuilding field, Japanese-style boats with an innovative feature that made the best of diesel's fuel efficiency became a smash hit.

Yanmar's FRP boats were growing steadily in sales as more and more wooden boats were replaced with FRP vessels, but in some culturing businesses, where boats of light draft were needed, outboard gasoline engines were preferred. Yanmar therefore developed the Z drive system with an outboard drive powered by a diesel engine mounted inside the boat, combining the economical efficiency of a diesel engine and the advantages of an outboard motor. This was installed on the newly developed ZD Japanese-style boat series. Aquaculture was then becoming widespread in Japan, and 8,000 boats were



A ZD Japanese-style boat (1978)

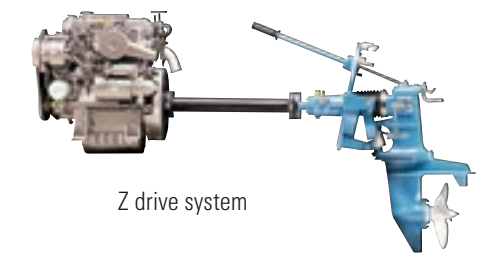

Z drive system



The Marine Hunter FZ22



The Marine Hunter FZ22 displayed at the Tokyo Boat Show (1983)

sold in just three years after the series was launched in October 1978.

Though the sales of FRP fishing boats continued to be strong, an overall look at the fishing boats industry indicated that business was getting tougher day by day. The 200-mile fishery conservation zone established in 1977, an increase in fish imports, and a shift away from fish due to changes in eating habits were accelerating the downturn in fish prices. The demand for fish was markedly declining.

Yanmar needed a product that could become a new pillar in the marine sector. The search led the company to pleasure boats. In April 1980, Yanmar introduced the Marine Hunter FZ22, our first pleasure boat equipped with the Z drive system. It sold over 400 units in the very first year. Gaining the trust of the market for its fuel efficiency and durability, the Marine Hunter became a series, and Yanmar entered the marine pleasure market full scale.

### Gas turbine

Simultaneous with the development of products based on the concept of conserving energy and natural resources, the company was also exploring the possibilities of a new internal combustion engine. This was the beginning of Yanmar's gas turbine business.

The Fire Service Act was revised in 1974 to mandate the installation of emergency generator equipment for buildings that were highly public in nature. However, when the Miyagi earthquake struck in 1978, there were incidents where diesel engine-driven emergency generators failed to operate due to damage caused to the cooling-water pipes.

This led to the reconsideration of gas turbines, which did not require cooling water for operation. Being light in weight and low in vibration and noise, gas turbines had the advantage of being installable on a roof. In 1980, Yanmar established the Large Power Products Department with the objective of developing and commercializing Yanmar's own gas turbine as quickly as possible, and entered into technical cooperation with Noel Penny Turbines Limited (NPT), a British company which boasted world-class cutting-edge technology. Yanmar entrusted NPT with the development of a 600 hp class gas turbine and dispatched engineers to their office to learn design, production, testing, and other techniques.

The following year, NPT developed the first of the P169 compact industrial gas turbine with the world's highest level single-stage centrifugal compressor. Based on this product, Yanmar developed in-house the

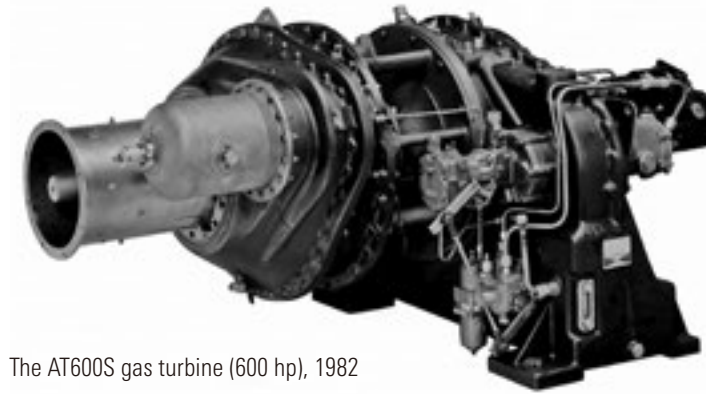

The AT600S gas turbine (600 hp), 1982



The AT1200S gas turbine (1,200 hp)

AT600S gas turbine (600 hp) for use in emergency generators in 1982.

Yanmar subsequently developed the AT1200S (1,200 hp) gas turbine, which had two AT600S units on a single shaft, and shipped out Yanmar's first emergency generator equipped with this gas turbine in 1984. The product captured approximately 30% of the market in two years and formed the base of a new business.

### Strengthening local production and advancing into the North American market

Under President Yamaoka's leadership, the overseas operations continued to grow year by year, but the method for developing business differed from area to area. In Southeast Asia, the company's most important market, the demand for engines and agricultural machinery was increasing, but considering the modernization policies in these countries, Yanmar shifted the business model from exporting finished goods to establishing overseas companies to assemble and manufacture Yanmar's products.

In 1975, Yanmar established P.T. Yanmar Agricultural Machinery Manufacturing Indonesia, a joint venture with a local company, to produce and sell agricultural machinery. Yanmar used a system called knockdown export, and exported all the major components for assembly in Indonesia. The year after its establishment, Yanmar Indonesia began to produce rice hullers and power tillers. In 1978, Yanmar founded Yanmar Thailand Co., Ltd. a joint corporation, in Bangkok and began production and sales of *yokosui* engines.

Meanwhile, Yanmar also made a full-scale entry into the North



P.T. Yanmar Agricultural Machinery Manufacturing Indonesia (1975)



Yanmar Thailand (1978)





Compact utility tractors (CUT)



Attaining a total tractor production of 100,000 units



Yanmar Diesel America

American market. The company had no choice but to enter this mega-market if Yanmar were to be accepted as a truly global company. The first products launched were compact tractors.

North America had a market for compact utility tractors (CUT), meaning small tractors of 40 hp or less used for cutting lawns or doing light construction work on ranches. Feeling that Yanmar's highly efficient tractors with a short turning radius had a good chance of breaking into the market, Yanmar began in 1974 to make test sales through a trading company. The results were positive, and in 1979, the company established Yanmar Tractor (U.S.A.) Inc. jointly with the trading company. The company sold products tailored to local specifications and received high marks on customer satisfaction surveys.

This drew attention from Deere, the world's leading tractor maker. Yanmar already had an agreement with Deere to import and sell their large-size tractors, but this time, they approached us with a proposition to sell Yanmar's small tractors in the United States and other countries around the world. An OEM contract was concluded in 1977, and Yanmar's compact tractors were supplied to North America and other countries under the John Deere brand.

At the same time, Yanmar entered a joint venture agreement and a joint research and development agreement with Deere, and established Yanmar John Deere Engineering Limited Company in Yanmar's Osaka head office to jointly develop compact tractors. In 1986, nine years after the contract was signed, production of compact tractors for Deere reached a total of 100,000 units. Against a backdrop of strong sales, Yanmar started OEM supply of *tatesui* engines to Deere in 1982.

In 1976, Yanmar signed an OEM contract for *tatesui* engines with Thermo King, one of the largest freezer and refrigerator manufacturers in America. Since this OEM continued to expand the volume of business, Yanmar established Yanmar Diesel America Corp. near Chicago in 1981 to develop further business with Thermo King and to promote sales of engines for industrial use in North America. With a sales office in North America, Yanmar began sales activities on a full scale.

In 1986, the company constructed a parts center capable of storing 30,000 different parts in Buffalo Grove on the outskirts of Chicago. By consolidating parts supply outlets in North America, the company wanted to prevent waste resulting from duplication

of stock and to provide faster supply of parts. Because all operations, including order taking, order placing, receiving and shipping of goods, inventory control, and location management, were computer controlled, complicated parts management could be performed rationally and efficiently, allowing the company to provide customers with accurate and speedy delivery of parts.

Meanwhile in the pleasure boat engine market, Yanmar's share was growing in North America as it was in Europe.

After two oil crises, interest in high-performance diesel engines with improved fuel efficiency drew the interest of the market, and the reputation for excellence Yanmar had established in the yacht and small boat engine market quickly grew. In France and Sweden, Yanmar had a monopoly. One hundred per cent of diesel engines exported from Japan to these countries were Yanmar engines. In 1983, Yanmar shipped 10,000 engines each to Europe and America. At that time in the West, engines for pleasure boats meant "Yanmar," and Yanmar proceeded to secure a leadership position in the market.

To handle maintenance and parts supply services for large-size engines, Yanmar opened offices in London, Athens, and Rotterdam between 1976 and 1977, and dispatched engineers to teach maintenance technology to the local staff. In 1978, Yanmar established an office in Dusseldorf in West Germany, and moved the functions of the London and Athens offices there in order to strengthen sales and services.

Outside Europe, Yanmar opened the Yanmar Technical Center in Dacca, Bangladesh, in 1978, and an office in Singapore in 1980. Then in 1983, Yanmar opened an office in Cairo, Egypt, to cover the large geographical area of the Middle East and Africa, aiming to identify and provide fine-tuned responses to local needs.

Japan, with its highly advanced technologies in energy efficiency and electronics, became a well-established economic power. The Yanmar Group takes pride in having played a role in the development of the Japanese economy through the products and services in each of the business sectors.



An integrated parts center in Chicago (1986)



A pleasure boat engine with a propulsion device



Venturing into New Businesses and Global Expansion

---

*1985-1997*





The finance ministers of five countries discussing the Plaza Accord (1985)

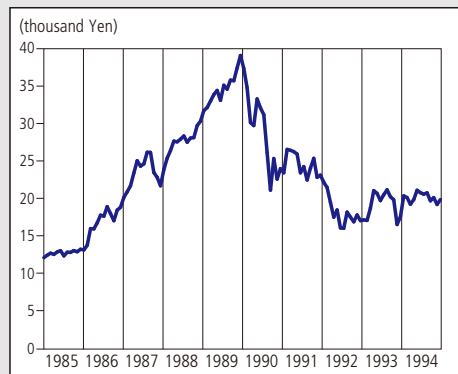

The change in the Nikkei Stock Average: The Nikkei Stock Average reached a peak of 38,957 yen on December 29, 1989, then plummeted

#### HISTORICAL BACKGROUND

Japan continued from the early 1980s to implement its strategy of expanding overseas. This resulted in a large trade surplus, about half of which was with the U.S., causing friction between the two countries. In September 1985, a group of five major nations signed an agreement called the “Plaza Accord” depreciating the overvalued U.S. dollar. This strengthened the Japanese yen, so that the exchange rate, which had been about 240 yen per dollar, quickly rose to 160 yen per dollar by May of the following year. Japan’s export industry suffered a serious blow.

In order to resolve this issue, the Japanese government lowered interest rates and gradually reduced the official discount rate to 2.5%, the lowest in postwar history. As a result, economic conditions improved after hitting bottom in November 1986, but the abundance of money in the market caused a steep rise in real estate and stock prices. Many individuals and companies began to buy and sell them for speculation purposes, using the stock and land valued at inflated prices as collateral. This brought about the bubble economy.

In June 1989, the Bank of Japan changed its policy to monetary restraint, and the Ministry of Finance set an “upper limit on borrowing” to restrict loans with land as collateral. Although land prices were still rising and optimism was still undiminished until 1992 when the government made an official statement admitting to an economic slowdown, Japan had already entered a long-term recession period called the “Lost Decade.”

## Implementing Special Emergency Measures

Working since the 1960s to expand exports, the company’s overseas sales reached 64.8 billion yen in 1984, accounting for 33% of the gross sales of 195.2 billion yen. However, after the Plaza Accord in 1985, the yen suddenly appreciated and put an abrupt brake on exports. Furthermore, the demand for large marine engines fell drastically due to the shipbuilding recession at the time, so not only did the company fail to reach its target of 200 billion yen in gross sales, but it also ended the 1985 fiscal year with an ordinary loss of 2.337 billion yen.

In announcing the company’s Business Management Policy for 1986, President Tadao Yamaoka said, “Our sales and profits are now suffering badly. The company has a very pressing issue to address.” Declaring a “state of emergency,” he announced the implementation of special emergency measures aimed chiefly at reducing and rationalizing operating costs in the two fiscal years 1986 and 1987.

The biggest task was the reduction of the ever-increasing fixed costs, the largest part of which was personnel expenses. Reform accompanied by pain could not be avoided. To reduce the number of employees to the minimum required in the foreseeable future, Yanmar asked for volunteers to resign, temporarily or permanently transferred employees to affiliated companies and sales companies, reduced the hiring of new employees, and reexamined the reemployment system after mandatory retirement. In these ways, the company cut 650 of its 4,750 employees.

In addition, the administration function was spun off. Five companies including a financing company and a building maintenance company were established, to which approximately 230 of the employees were dispatched. Aside from reducing employees, the company also took such measures as restricting investment in production facilities and research and development, selling idle assets, and partially cutting back on salaries and bonuses.

Even that was insufficient. The 1986 fiscal year again saw a decrease in income and a large deficit. Overseas sales also dropped to 45.3 billion yen, a 28.4% decrease compared to the previous year.

## At the mercy of the bubble economy

In the mid-1980s, the overall Japanese economy faced a depression due to the rapid appreciation of the yen. The government attempted to overcome this plight by expanding domestic demand by means of lowering interest rates, and gradually reduced the official discount rate from 5 to 2.5%. This extremely low interest rate policy took effect, and business in Japan began an upturn after hitting rock bottom in November 1986. Yanmar's special emergency measures also proved effective, and business started to look up. Gross sales for the 1987 fiscal year were 176.4 billion yen, an increase of 5.8% over the previous fiscal year, and ordinary profit was 2.8 billion yen, the first surplus in three years.

Japan managed to emerge from the economic depression caused by the appreciation of the yen, but low interest rates continued, and corporations began to spend surplus funds for speculative purchasing of stocks and real estate. Land prices soared, and a “land myth” prevailed that “land prices will never decline.” It was even said, “The land in Tokyo inside the Yamanote line is worth as much as all the land in the United States.”

Speculation fever spread among individuals as well, and even paintings and golf club memberships became objects of speculation. This prosperity, which made all of Japan almost delirious with speculative fever, continued even after the name of the era was changed to Heisei. However, an economy without substance always comes to an end. Voices expressing concern over the outlandishly inflated land and stock market prices grew louder every day. And when the Bank of Japan and the Ministry of Finance implemented a monetary restraint policy, stock prices, which had reached their peak at the end of 1989, plummeted by almost half by the fall of the following year. Subsequently, property prices also started falling. The Japanese economy cooled quickly, and only bad debt was left behind.

The company's sales stayed about the same from the 1991 fiscal year forward. From this, it may not seem that the company was affected much by the collapse of the bubble economy. However, ordinary profits decreased every year till the 1993 fiscal year. In 1992, it became evident that Yanmar's finance subsidiary, Y. D. Finance Co., Ltd. and Yanmar Agricultural Equipment's finance

subsidiary, Yanmar Finance Co., Ltd. had generated a total loss of over 50 billion yen in securities investments.

The year 1992 marked the 80th anniversary of the establishment of the company. It was a big turning point. However, faced with an increasingly severe business environment, diversification of business structure, and numerous associated problems, the atmosphere in the company was anything but celebratory.

## Challenges and failures in new businesses and new products

While implementing special emergency measures, President Yamaoka was also eager to create new business opportunities. In order to respond to the ever-changing business environment, he said, each employee should think outside the box, and with a flexible approach, make efforts to develop new businesses and products. Failures come hand in hand with new endeavors. There are things that can be learned only through failures. Repeatedly emphasizing the importance of trial and error, President Yamaoka pointed out that the important thing was to “take action” without fear of failure.

In order to put life back into the company, which at the time seemed smothered in a sense of helplessness, employees needed new challenges that would enable them to regain hope, challenges that would lead to a better future. For this, the “Challenge 100 Proposal Campaign” was conducted in January and February of 1987 to seek ideas from employees for new businesses and products.

The response it received reflected the sense of crisis felt at the time. Many employees were concerned, and groups within the company submitted 653 ideas. In November of the same year, the company decided to turn eight of these ideas into businesses, with high priority given to the realization of those closely associated with the company's core businesses, such as entry into the aquaculture market and the development of the marine pleasure boat business.

In March 1988, Yanmar Marine Farm, a center for the research and development of a future fishery system was opened within the site of Yanmar Shipbuilding & Engineering Co., Ltd. on Kunisaki Peninsula in Oita Prefecture. The facility was established under the concept of conducting research and development in producing juvenile fish, in other words, hatching eggs artificially on land and



“Challenge 100 Proposal Campaign”



Yanmar Marine Farm (1988)



10-ton class aquaculture tanks at Yanmar Marine Farm



releasing them into the sea, improving species through the use of biotechnology, and fishery-mechatronization. Its other operations included offering expertise on fish farming from culturing to distribution, and providing consultation services.

Upon opening, Yanmar Marine Farm invited fishery specialists as full-time researchers, and asked specialists at universities and private laboratories to act as engineering advisors. The facility included two breeding buildings, two 10-ton class tanks, and 20 smaller tanks. In 1990, Their Imperial Highnesses Prince and Princess Akishino visited the farm and inspected the cutting-edge equipment and research work.

In February 1989, the company established Yanmar Marinax Co., Ltd. and entered the marine pleasure business on a full scale.

The marine pleasure boom in Japan took off after the enactment of the Law for Development of Comprehensive Resort Areas (Resort Law) in 1987. This boom, against the backdrop of the bubble economy, served as a strong tail wind for the company's advance into the pleasure boat market. The company not only sold Marine Hunters, but also imported and sold luxury pleasure boats from the U.S. and Italy. Yanmar opened shops in various places and began holding scuba diving classes and offering various tours. However, when the bubble economy collapsed, the boom slowed down, and the company downsized the business and transferred it to Kinki Yanmar Co., Ltd.

Meanwhile, agriculture in Japan was facing a major turning point. Rice prices had dropped for two consecutive years, and the government had liberalized imports of eight agricultural products. The aging of farmers, the consequent downsizing of farms, and the increasing number of people giving up farming also began to surface as serious issues. The future of the agricultural equipment market was unclear. Faced with this severe situation, Yanmar Agricultural Equipment decided to try its hand at different fields to seek new sources of income.

First, it began selling cordless phones in December, after the revision of the Radio Law was put into effect in October 1987. In October of the following year, it established Yanmar Dream Agency Co., Ltd. jointly with Japan Travel Bureau, Inc. (present-day JTB Corporation) to respond to the growing demand for travel among farmers and residents in agricultural areas. In December, they formed a tie-up with a major apparel manufacturer and entered the



Yanmar Marinax established in Osaka (1989)



IG Shop, a car-leasing agency

mail-order business. Its finance subsidiary also began new businesses in communication lines and car leasing.

Yanmar Agricultural Equipment did not have an internal production department, but it did have strong assets including a powerful brand name, a sales network spread across the country, and customers numbering 1.2 million. So what if products were different. It was foolish not to use the sales network that had been cultivated over a long period by establishing trust. Besides, they wanted to ride the wave of the recovering economy and increase their sales.

However, most of the businesses they started were so far from their core business that they had to be reduced in scale or withdrawn from altogether.

## Placing hope in the future of agriculture

Yanmar Agricultural Equipment tried many new businesses while their core business experienced a recession, but when most ended in failure, they decided to take another good look at itself and initiated the “Stance 21 Strategic Committee” to discuss and develop a business vision for the 21st century.

The debate continued from December 1990 to July of the next year, and the conclusion drawn was that their stance was to remain committed to and to continue to be involved in agriculture. They regretted having so easily rushed into different fields without seriously facing the challenges of their core business. They also felt the need for a goal toward which all the employees could strive together as one.

Prior to this, the Yanmar National Agricultural Machinery Distributor and Dealer Meeting held in January 1990 proclaimed the slogan, “Japanese agriculture is more exciting than ever.”

This was a time when foreign countries were strongly demanding that Japan open its agricultural markets. There was also a national trend away from consuming rice, so pessimistic views concerning the future of agriculture in Japan were widespread not only among farmers and the farm equipment industry but across the whole economy. Some people expressed displeasure at the slogan saying, “What can possibly be exciting?” They complained that they would not be able to explain it to the dealers who were having such a hard time working on the front line of sales.



The slogan “Japanese agriculture is more exciting than ever” (1990)

However the intention of this slogan was not to make a show of eccentricity, but to shed a light of hope for a brighter future in agriculture. Though conditions were severe, some people were searching to find new agriculture, and there was hope in the expanding global demand for food accompanying the rapid increase in population.

At the time, Yanmar Agricultural Equipment was celebrating its 30th anniversary, and to commemorate the event, it held a Student Essay Contest. Thinking it a good opportunity for the young generation to consider the future of agriculture and farming villages, they invited essays from students on the topic of the mentioned slogan. There were 83 entries in the first competition out of which one Grand Prix (1 million yen) and four Excellent Prizes (prize of 300,000 yen) were selected. Also as corporate cultural activity, they published a portrayal of the life of present-day farmers.

As if in response to these activities, changes occurred in the direction of government policies regarding agriculture. With technology and creativity, results can be achieved despite external factors. With this belief in mind, the government began to foster large-scale full-time farmers with an excellent sense of management.

## Responding to the polarization of agriculture and the mechanization of vegetable farming

While small part-time farms increased in number, full-time farms grew into large farms, resulting in the polarization of agriculture. Since the type of farm equipment required differed depending on the size of the farm and the user of the machinery, Yanmar and Yanmar Agricultural Equipment dedicated energy and effort to developing functions that satisfied both small and large farms.

The Ke-2 (12.5 hp) and Ke-3 (13.5 hp) compact tractors launched in 1988 were easy to operate, had a short turning radius, and were reasonably priced. Satisfying the needs of small part-time farm households whose main workers were women and the elderly, they became hit products. Based on the same development concept, the company introduced the Pe-4 compact, lightweight riding rice transplanter the following year, and the Ee two-row reaping combine series in 1995. They were extremely popular among small farms and farms in hilly and mountainous areas, and greatly expanded their share in the market.



The awards ceremony of the first Yanmar Student Essay Contest (1990)



The Ke-3 tractor (13.5 hp)

Then in 1998, the Pe-1 riding rice transplanter was introduced. Lightest in the industry and priced at an affordable 650,000 yen, which was almost the same as the walk-behind transplanter, it was overwhelmingly popular. The machine achieved record sales, and the company's four-row rice transplanter acquired a market share of over 40%.

As to large-scale full-time farmers, the company answered their needs with powerful, low-fuel consumption tractors. Especially popular was the EcoTra series, equipped with a high-speed tillage rotary and a direct-injection eco-diesel engine employing electronic governor technology.

The tillage speed increased by 1.5 to 1.8, shortening work hours by 30 to 40% and reducing fuel consumption by 30 to 50% as compared to conventional machines of the same horsepower. Because Yanmar wanted farmers to first confirm its performance, the company conducted the "Test Ride for a Million Visitors" campaign when it was first introduced, and received support from farmers all over the country. The industry also rated it highly, and it received the "Nihon Keizai Shimbun Award for Excellence" in the "Nikkei Superior Product and Service Award" category in 1996, and the Japan Machinery Federation Chairman's Award as the superior energy-saving machine of 1999.



The Pe-1 riding rice transplanter



An EcoTra series tractor



A "Test Ride for a Million Visitors" campaign



Receiving the "Nikkei Superior Product and Service Award" (1996)





The large multi-purpose combine, CA1200

The company also applied advanced technology to the combines and rice transplanters, and continuously developed models that were large in size yet comfortable and easy to maneuver. For example, the CA1200 large multi-purpose combine jointly developed in 1994 with the Bio-oriented Technology Research Advancement Institution (present-day Independent Administrative Agency, National Agriculture and Food Research Organization) had a horsepower of 120, a wide cutting width of 3.6 meters, and a big grain tank of 2,400 liters. It also had a round steering wheel giving it a passenger-car feel. It was an epoch-making product that indicated what a combine would be like in the future.

Because of the revolutionary progress made in agricultural equipment, highly advanced mechanization of rice cultivation was realized. However, this also meant the leveling off of demand. In addition, the rice surplus and a change in eating habits away from rice was leading the agricultural machinery industry into a cul-de-sac.

They next set their eyes on vegetable farming. Aiming at creating a complete and consistent system for growing vegetables from seedling to transplanting and harvesting, just as they did with rice, Yanmar Agricultural Equipment developed the NAPLA system. Incidentally, NAPLA is the abbreviated name for “*nappa* plant” or “green vegetables.”



The CP-1 vegetable transplanter

In order to develop a new market, they first launched the NAPLA cell tray for seedlings in 1991, followed in March 1992 by the CP-1 vegetable transplanter. However, since they were not standardized as were the paddy rice mat and rice transplanters, Yanmar Agricultural Equipment along with Bio-oriented Technology Research Advancement Institution, developed a new cell tray with standardization in mind. The finished product was authorized by the Ministry of Agriculture, Forestry, and Fisheries and became the standard specification in the industry.

In 1995, Yanmar launched the HN2 first-in-the-industry two-row carrot harvester. The company has since continued to develop machinery for various vegetables.

Business at Yanmar Agricultural Equipment stayed sluggish for some time, but several incidents that occurred about this time triggered its recovery.

One was the emergency imports of minimum access rice (minimum amount of foreign rice which must be imported) determined by the Uruguay Round. The government took various budgetary



A cell tray

measures to mitigate the impact on domestic agriculture and greatly increased financing for agricultural facilities. Because of this, orders for new facilities, as well as for expansion and alteration of existing facilities, kept coming from all over Japan, and sales in the facilities business showed remarkable growth. Orders included facilities new to the industry, such as a fruit-sorting plant to sort apples by color, and DAG, a facility with a new storage system that protected the flavor of grain by drying them by discharging dehumidified air without using heat. As a result, business expanded significantly to cover a broader scope.

The other incident was the business tie-up with Ishikawajima-Shibaura Machinery Co., Ltd. (present-day IHI Shibaura Machinery Corporation). They had an outstanding history in the tractor business, as well as abundant technology and know-how in tillers for dry field farming.

The tie-up agreement, concluded in 1991, established a cooperative framework regarding development and production, and transferred Ishikawajima-Shibaura Machinery's domestic sales network to Yanmar Agricultural Equipment. Dispatching their sales staff of 200 to Yanmar Agricultural Equipment, Ishikawajima-Shibaura Machinery took this chance to withdraw from domestic sales and concentrate on the development, production, and export of tractors and tillers.

Acquiring not only technology but also a sales network that Ishikawajima-Shibaura Machinery had built up over a long period was a powerful tailwind for Yanmar Agricultural Equipment. In 1993, the first Yanmar-Shibaura tie-up tractor, the Forte AF series, was launched. Equipped to meet the industry's highest level specifications, the series gained popularity. Riding an updraft, Yanmar Agricultural Equipment's sales exceeded 200 billion yen, and the company has continued to improve its performance since then.

## Thriving business in excavator and other compact construction machinery

While many businesses were floundering in the latter half of the 1980s due to the economic depression caused by the appreciation of the yen, the construction equipment business grew rapidly.

Housing starts, which had fallen off temporarily, began to pick up from 1984, and when the bubble economy emerged following

### Further concessions predicted over rice



Emergency imports of minimum access rice (1993)



A facility for sorting apples by color



Business tie-up with Ishikawajima-Shibaura Machinery (1991)



**HISTORICAL BACKGROUND**

As it passed through the Meiji Restoration on its way to becoming a modern nation, Japan got started on the right track by means of the new government's policies, including "enrich the country, strengthen the military" (*fukoku kyohei*) and "increase production and promote industry" (*shokusan kogyo*), achieving rapid industrial development. Government-operated enterprises actively introducing Western industrial technology were established in various parts of the country. Raw silk and cotton goods produced by the Tomioka Silk Mill and the Hiroshima Spinning Mill expanded exports and eventually the silk reeling and spinning industries developed into major enterprises driving the Japanese economy. Before long, these various businesses were transferred



Yanmar Construction Equipment product range (1990)

to private ownership, and when the textile industry, mines and cement plants passed into private hands, modernization spread into heavy industries such as iron manufacturing and shipbuilding.

Simultaneously, whereas steam engines had long been the main source of power, gas, petroleum and electricity became newly diffused.

The Meiji era gave way to the Taisho era in 1912 and the First World War broke out in 1914, and Japan was flooded with orders for munitions and the wartime economy boomed. Once the war came to an end, a postwar crisis ensued and that, together with

the 1923 Great Kanto Earthquake, accelerated the floundering of the economy. Subsequently, with the beginning of the Showa era in 1926, Japan's economy entered a long, dark tunnel marked by the so-called Showa financial crisis in Japan and the collapse of the stock market in New York. The Japanese economy seemed so bogged down that there was hardly a glimmer of light on the horizon.



The ultra-tight-turning mini excavator, B3

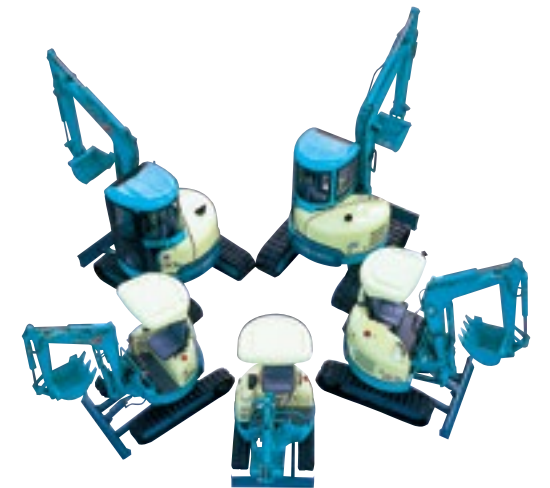

The ViO excavator series

## From the countryside to Osaka harboring lofty ambitions

In the Kohoku area in Shiga Prefecture, lay the Ibuki Mountain range and an isolated village that looked out over Lake Biwa. No matter where one looked, everything was covered in snow. When a late spring finally arrived and the snow finally melted, all that appeared was a small patch of thin arable land. Unblessed with the conveniences of irrigation or water supplies, the land yielded only a meager harvest, regardless of how much effort went into it. Then the snows came, making the land impenetrable again.

Needless to say, this region could not compare with Tokyo and Osaka, which were steadily progressing down the path of modernization, but it was even poorer and more desolate than the Koto and Konan areas of Shiga Prefecture. The single factor that suggested some degree of modern civilization was the railroad at Nagahama that connected with Tsuruga, a port which traded with the continent.

A young man once stood lost deep in thought as he looked at the narrow dark railroad line stretching across the snowy landscape.

‘In this poor village where there is absolutely nothing to do, what kind of future do I have? I wonder what sort of world lies at the other end of that railroad line.’

That young man filled with desire to leave his home province for some unknown destination was none other than our founder, Magokichi Yamaoka.

Magokichi was born on March 22, 1888, in Minami-Tominagamura, Ika-gun, Shiga Prefecture (present-day Takatsuki-cho, Higashi-Atsuji, Nagahama). He was the sixth son of his father Chuzaburo and his mother Kuni, and the ninth of ten children. His father worked as a carpenter on the side while cultivating a small plot of land roughly 2,000 square meters in size, which he inherited when starting a new family line. It was not easy to earn a livelihood on such a minimal piece of land, especially given the number of children in the family.

In the village, it was common practice for the children, once they had completed primary school, to go off to the city and become an apprentice. However, Chuzaburo had himself served as an apprentice, and hoping to have the robust, diligent Magokichi succeed to the family trade, he was unwilling to let his son go.



The Vi015 excavator

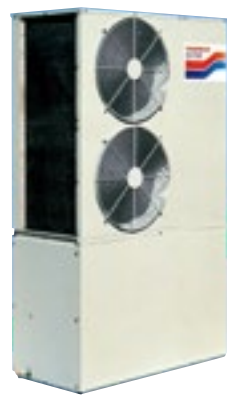

A gas heat pump (GHP) air-conditioning system

Seeing the impoverishment of his village and the dire financial straits of his family, and watching the young men of the village leave one after another, Magokichi's unease and impatience worsened. At the same time, his yearning to experience the outside world grew stronger and so intense that he could no longer hold his feelings inside.

Around the young age of 14, two years after attending school for only six years, Magokichi resolved to leave for the United States. There was an emigration boom at that time, and emigration brokerage agencies were loudly clamoring that whoever went to America would become enormously successful. Magokichi was overflowing with enthusiasm, so perhaps it was only natural that since he had decided to leave the village, he might as well go overseas.

Without letting his parents know, he set off on foot for an emigration agency in Hikone, some 25 km distant. When he arrived at the agency, however, what he encountered was completely unexpected.

In order to emigrate, one first of all had to have the permission of one's parents and, second, pay a security deposit of 180 yen. Setting aside getting the consent of his parents, 180 yen was an enormous sum. At that time, a 60 kg bag of rice cost about 3 yen 60 sen, so 180 yen was way beyond what a young man his age could gather together.

Tearfully, he decided to give up his plan to emigrate. Nonetheless, he was unable to cast aside his plan to leave the countryside. In 1903, at the age of 15, Magokichi brought up the matter with his mother Kuni. ‘I want to go to the city, become an apprentice and save 10,000 yen.’ His mother, who herself had been an apprentice in Hyogo Prefecture and who regularly grumbled about the inconveniences of country living, understood his feelings and encouraged him. While Chuzaburo was away doing volunteer labor in a temple in Kyoto, she sold a bag of rice for 3 yen 60 sen to make it possible for Magokichi to leave his native home.

At dawn on February 6 of that year, Magokichi put on his dark-blue cotton clothes, shouldered his wicker trunk and headed off, brimming with hope. His destination was Osaka, where his oldest brother Eitaro was working. Each time he looked back over his shoulder, he saw his mother standing in the doorway of their house.



Multi-air-conditioning system for buildings



Outdoor units of multi-air-conditioning systems for buildings

She stood there until he was completely out of sight.

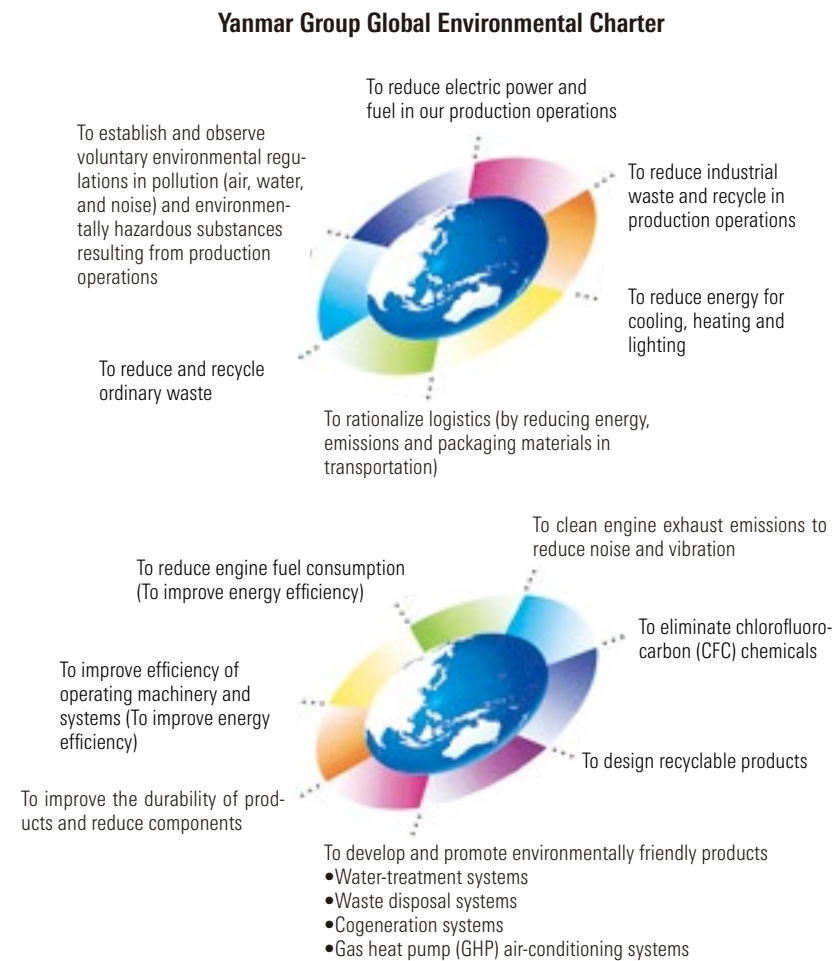

## Establishing Yamaoka Gasu Shokai

The Industrial Revolution, which began in Britain in the mid-18th century, spread to the major cities of Japan roughly a century later. When Magokichi arrived in Osaka, it had become an industrial city that was often referred to as “the Manchester of the East.” It had all the features of a major city perfectly suited to feeding a young man’s ambitions, but he quickly encountered the harsh realities hidden under the glittering surface.

Taking refuge with his brother Eitaro in Sonezaki, Kita-ku, Osaka, Magokichi as a temporary step became an apprentice at a knitting shop in Higashi-Tenma, where from early morning until late night he kept at the hard labor of spinning the spindles of the knitting machines. By the end of the third day, he left. In succession, he tried working at a variety of trades, from soap manufacturing to cotton-fabric wholesaling to production of mounting paper for photographs. But the life of an apprentice did not suit his personality and he could not get used to life in the city. As a result, his physical condition deteriorated.

As he recovered for a while at his brother’s house, his condition gradually improved. He began going to the nearby Dojima River to fish, something he had enjoyed since childhood.

The green leaves of the willow trees along the beautiful riverside reminded him of the scenery of his home village and he felt completely at ease. As he lazily dropped his fishing line into the river, he noticed the hurried coming and going of a large group of workers in a nearby shack-like building.

A short time later he struck up a conversation with a few of the people working there and found out they were employees of the Osaka Gas Co., Ltd. and that the building was the operations office. He had no idea what kind of business a gas company did, but from the bustling in and out of the employees, he figured that business must be quite good. Deciding that he would hardly continue forever depending on his brother for food and lodging, Magokichi decided to take a chance and ask the site supervisor for a job. To his great surprise, the supervisor hired him.

So in April 1905, at the age of 17, Magokichi, as the result of a completely coincidental encounter, obtained employment as a pipe installation worker at Osaka Gas.

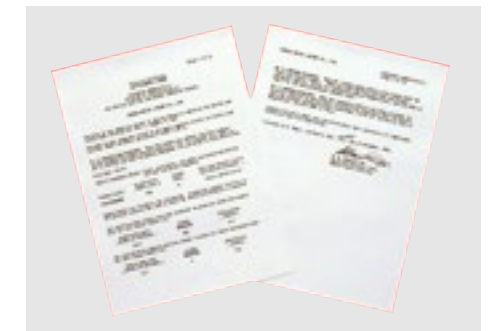

Certified by CARB (1991)



At that time, Osaka was rapidly modernizing and the installing of basic infrastructure was proceeding at a rapid pace, with gas piping being laid throughout the city. From the perspective of the company, which was severely hampered by a shortage of labor, Magokichi's application for a job could not have come at a more opportune time. The daily wage was 42 sen and one could work a day and night shift and earn 84 sen.

From October 1905, a half year after he started work, gas was available in every part of the city and the diffusion of gas engines began. Gas engines, unlike steam engines, did not require large amounts of space. Operating such engines was easy, so they were rapidly being installed in various businesses from small factories in town to movie theaters.

Spurred by the need, Magokichi became involved in the installation of such engines. His work gave full play to his inborn diligence and inquiring mind. As he accumulated experience at various work sites, he learned the principles and the construction of engines.

In addition to polishing his technical engineering skills, he also learned the business side. As the number of places to which gas was supplied increased, a shortage of rubber piping developed. When he happened to see a huge quantity of rubber pipe at a trading company where he was doing some installation, he thought it was rather strange, so he asked about it. He was told that everything was being imported from Britain and during shipment the surface of the rubber hose had dried out. The trading company was perplexed over how to dispose of the hose. When Magokichi stretched out the hose, he could see the netlike pattern of small cracks on the surface, but he noticed that the inner surface was not damaged at all, so there would be no problem in using it.

It would be wasteful to simply dispose of it, so he offered for a small sum to help the person seeking to get rid of it. Taking into account that Osaka Gas was currently selling rubber piping at about 12 sen per 30.3 cm, he bought the piping for 6 sen and then sold it for 8 sen. It sold like hot cakes. Even when he raised the price to 12 sen, buyers paid without a word of complaint. He felt a certain degree of guilt about selling the pipe to people who were unaware that it was damaged, but in no time at all he made a total profit of more than 7 yen.

It was his first direct experience in the engrossing aspect of business. With this opportunity, Magokichi made a decision. He had



The 4TNE94 and 98 engines (35.3–51.1 kW)

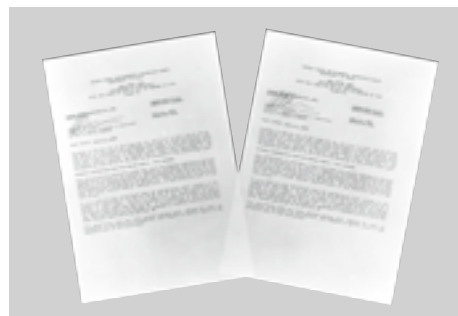

Certified by EPA (1996)

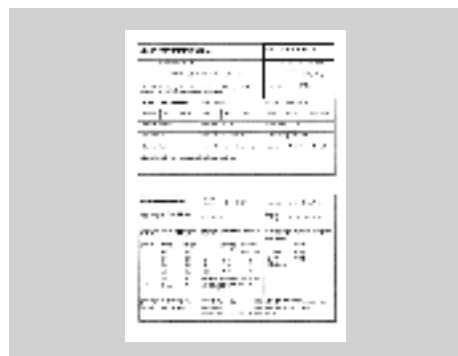

Certified by BSO (1992)



A "SAVETEN" eco-diesel series engine



Certified by IMO (1998)

promised his mother when he left home that he would save 10,000 yen—a preposterous sum for a regular worker like himself to accumulate. However, if he were to establish his own business, the odds for doing so might not be so ridiculous.

Magokichi quit Osaka Gas, started up his own gas pipe installation and equipment sales business in the summer of 1906. By the end of the year, he had earned a profit of 1,000 yen. With this as seed money, in March of the following year he rented a row house in Tenmawataya-cho, Kita-ku, Osaka; had a telephone installed; and opened a businesses called Yamaoka Gasu Shokai (trans. *Yamaoka Gas Company*). That spring, Magokichi turned 19 years old.

Due to the establishment of one gas company after another and the rapid diffusion of gas engines, there was no shortage of work. In addition to taking on two clerks, he sent for his younger sister Kon from back home and even added his brother Eitaro to the staff.

Work led to more work. The new company would buy gas engines that were left unused at the sites where they did installation work. When they repaired the engine and restored it so that it was as good as new, they created a sensation. The rebuilt engines were much cheaper than brand new engines, and on top of that, the installation was done without charge. That was one reason for their success, but another was that because they obtained the old engines for practically nothing, the profit margin was far greater than in any other kind of work. In the countryside where there was no municipal gas, they sold remodeled suction gas engines with gas generation equipment attached.





Biwa Plant (1995)



Processing lines



Assembly lines

Before long, this new enterprise became the core business. By considering what people were looking for and how to make people happy, the company tied new business to the services they offered. Magokichi's keen sense was polished day in and day out in the commercially prosperous city of Osaka, forming the groundwork by which the small, privately-owned shop progressed rapidly toward becoming a manufacturer.

### Founding Yamaoka Hatsudoki Kosakusho, the predecessor of Yanmar

In the process of handling a large number of repairs and renovations of gas engines, the row house in Tenma became too small. In 1912 Magokichi leased a 230 square meters piece of land at present-day 1-32 Chayamachi, Kita-ku, Osaka. He gathered together 5 engine lathes, established a repair shop with an office, and gave it the name Yamaoka Hatsudoki Kosakusho (trans. *Yamaoka Engine Company*). Its first day of business, March 22, is celebrated as the foundation of what would later become the Yanmar we know today.

The company employed another seven or eight factory workers, but Magokichi, covered with oil, continued working as usual while actively leading the way. The company got off to a favorable start, but the wave of modernization brought forth unexpected developments.

In 1913 Ujigawa Denki (trans. *Ujigawa Electric*) constructed a large-scale hydroelectric power plant, providing the Kyoto-Osaka area with electricity. In addition, the company began to sell electric motors. Just as gas-powered engines were finally coming into general use, they were becoming antiquated. Dealers in the buying and selling of gas engines in Osaka unfortunately ended up going out of business one after another.

Magokichi did not sink into low spirits. To the contrary, he simply shook off this apparent setback. Magokichi had twice as much enthusiasm for pursuing knowledge as the next person, but because of his family's circumstances he had been unable to receive sufficient education. Thinking that by adding to his store of knowledge he could make up for his lack of learning, he took advantage of every occasion to travel around and observe.

No information could be more dependable, he thought, than the information he could gather with his own two legs and his own two eyes. Urban areas like Osaka had become supplied with electric power, but Magokichi knew that the countryside was still dependent on gas. Looking at the broad market, he knew that the demand for gas engines and suction gas engines was actually on the increase.

One by one, Magokichi began buying, repairing and renovating the no longer needed gas engines he could find in Osaka. Once they were rebuilt, he traveled from city to city in western Japan and to the textile manufacturing regions of Senshu, Nishiwaki, Tango, Kaga and Enshu selling these engines. The demand was so great that the company was unable to handle all of the repairs and rebuilding. By seeking cooperation from nearby ironworks, he continued his sales visits.

### Wartime boom and postwar recession

World War I broke out in July 1914. The export of war supplies from Japan, far from the main theater of the war in Europe, led to an unprecedented boom. In response to the prosperity of industrial



Granted the Good Design Award (1996)



Yanmar Global Distributor Convention (1996)



circles, the demand for gas engines increased. Yamaoka Hatsudoki Kosakusho rode this “special procurements boom” and by war’s end reached profits of more than 300,000 yen. It was an enormous sum, equivalent to several hundred million yen today.

However, the favorable circumstances did not continue very long. In November 1918, Germany and the Allies concluded a cease-fire agreement and the result was a sudden reactionary recession, in which orders for gas engines ceased completely.

Magokichi decided to take time off and refresh himself. Until then, he had continued working at a feverish pace, but he had suddenly grown to dislike the business of buying something from one person and then selling it to someone else while making a profit as a go-between.

Looking back, while he felt gratified as an engineer repairing and rebuilding gas engines, as the business grew larger, without fully recognizing it, he had fallen into taking the attitude that any means used in the process of selling something was justified. This had not been his original intention and it was not the kind of work one could devote one’s life to.

The following was a case in point. An engine that Magokichi had sold was crated and on the way from Hakata harbor to Ikinoshima in Nagasaki Prefecture, the ship carrying it encountered stormy seas and sank. With the help of the insurance company, the ship was raised. Magokichi headed to Hakata, ordered new parts, fixed the engine and once again shipped it off to Ikinoshima. On the train going back to Osaka, he suddenly thought to himself, “What have I done? That engine shouldn’t be used anymore. All I was thinking about was that I had sold it!” (Magokichi Yamaoka, *Watashi no Ririkisho*, trans. *My Personal History*). He regretted his thoughtlessness. It saddened him to think that somewhere deep in his heart he had simply taken advantage of another person’s misfortune to make a profit.

Such experiences accumulated and finally, he grew disgruntled with being a broker by trade. This feeling was further strengthened by the low spirits he fell into as a result of the recession that followed the end of the war. By this time, he was already married and had a son named Yasuhito. Magokichi decided to return to his home village, with wife and son, in May 1920.



Yanmar Europe (1988)



An assembly plant for small marine engines at YEU



Amman-Yanmar (1989)

## Start of a new career as a manufacturer of oil-powered engines

Back in his native place, his father Chuzaburo had already passed away. But his mother Kuni, who had stood in the doorway seeing him off that day long before, was still in good health. Kuni was absolutely delighted at the hero’s welcome given to Magokichi, who was the most successful person in the village. In her expression, Magokichi realized how hardened his own heart had become and he was comforted.

However, having always had his eyes focused on what was happening in the world and managing various kinds of businesses, the tranquil country life eventually became boring.

He had 300,000 yen on hand. The economy had not yet recovered, but even if he were to lose half of what he had gained so far, the desire to do some kind of work came to the fore once more. In August 1920, three months after he had arrived, he headed back to Osaka.

In March of that year, the Japanese economy had been caught up in the great turmoil resulting from the postwar crisis and there were bank runs one after another. All that awaited Magokichi, who returned to Osaka in the midst of this turmoil, was a stock of 30 gas engines stored in the repair factory.

The work that he had anticipated had abruptly stopped and there was not a single phone call from a customer. After days of opening for business and having no business at all, he abandoned



An assembly line for L model engines at Yanmar Cagiva



A powerboat

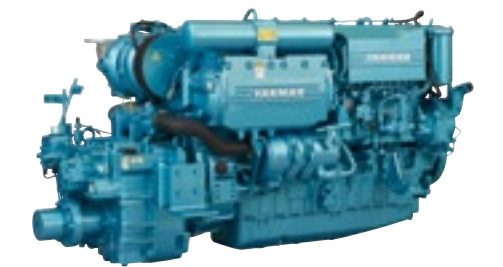

A 6LY series (315-350 hp) engine



the handling of gas engines completely. Just as he was beginning to consider what to do next, a certain person came to mind. The man was Sentaro Okoshi.

Okoshi had been his coworker during his time at Osaka Gas. After that, Okoshi had returned to his native place in Marugame, Kagawa Prefecture, and had operated an ironworks. He had purchased several 3 hp gas engines from Yamaoka Hastudoki Kosakusho. When Magokichi inquired what he was using the engines for, Okoshi had replied that he converted them to oil engines to power rice hulling machines and sold them to farmers. Curious about what this was all about, Magokichi decided to pay a visit to his friend in Marugame.

“Fix the mill so the underside turns, and it turns by way of a thick hemp rope powered by a rebuilt oil engine. This way, where five people turning the mill by hand do 300 kg of rice in an hour, the engine-powered huller will do 1800 kg of rice—a six-fold production.” (*Watashi no Rirekisho*)

Magokichi knew intuitively that he had found something important. He knew immediately how valuable a “powered rice huller” could be.

If one could develop a light-weight, portable, convenient oil-powered engine, it would clearly reduce the heavy labor of the farmer. He made up his mind to produce just such a machine. It would not be the kind of work where he could make a profit without putting out a lot of effort. But he could make something that would benefit others and he could become a manufacturer who could be proud of what he provided.

### Birth of “Yanmar” products

With the objective set, all that remained was to implement it. Upon returning to Osaka, he purchased an imported oil-powered engine used for shearing wool and immediately set to work. The lightness of the engine body would be maintained, and through repeated rebuilding, he gradually developed an engine that would stand up to the hulling process. Three months later, in November 1920, a prototype of an agricultural-use 3 hp vertical oil-powered engine was completed. It was one-fifth the weight of the engine that was used in Marugame, at a light 110 kg. It was both Magokichi’s first monumental product as a manufacturer and also Japan’s first

oil-powered engine designed specifically for agricultural use.

In March 1921, he developed a horizontal oil-powered engine and gave it the name “Yanmar throttle-governed oil engine.” The “throttle-governed” referred to the saving of fuel due to altering the revolution speed by means of a governor, a speed regulator, which at the time was a unique design.

This product was the first to be given the name “Yanmar,” but a number of complications arose before deciding on that trademark.

Magokichi recalled his father Chuzaburo comment, “There are lots of dragonflies (*tombo*) this year, so it’s bound to be a great year for crops.” With this image of an abundant harvest in mind, he considered taking “*tombo*” as the trademark. However, another manufacturer had already registered that name. He was considering purchasing the trademark from the current owner, when one of his employees made a suggestion. “Rather than doing that, how about taking the name ‘*yanma*,’ the species of large dragonflies that are called ‘king’ of all dragonflies?”



Tuff Torq (1989)



Yanmar Asia (Singapore), 1989



Yanmar Agricultural Equipment (China), 1999



The Ce-1 combine harvester

“*Yanma*.” The name sounded appealing to Magokichi. He also liked the fact that it was somewhat close to “*Tamaoka*.” To make it easier to say, he decided to extend the final vowel sound so that it became “*yanmaa*” (English transliteration: Yanmar).

### Aiming for the diffusion of engines for agricultural use

While the company had put its original oil-powered engine on the market, at that time there was still no concept of “engine-driven farm work.” To spread the idea, it would be necessary to demonstrate to farmers just how helpful such equipment could be.

Magokichi set to work developing machines that could be connected to oil-powered engines to perform farm labor, and in September 1921, the company put on sale a powered rice huller. He hauled one to his hometown, Higashi-Atsuji and gave a public demonstration to an audience of farmers. Not only was it capable of hulling 1800 kg of rice in a single hour but the hulled rice grains were cleanly processed. Everyone attending was amazed.

Use of the mechanism was offered free of charge throughout the village and a demonstration was also presented to people gathered in front of Nagahama station. On that occasion they charged about 750 g per 60 kg of rice, but there was no end to the people who came to have their rice hulled. In addition to earning a small fee for hulling, the demonstration was great advertisement, killing two birds with one stone. Furthermore, the company put advertisements in the newspapers saying, “If you purchase one of these powered rice hullers for 650 yen and loan it out for a fee, you can make a profit of 1,000 yen during a single autumn.” As a result, orders poured in from all over the country. In fact, orders were so numerous that at one point production could not keep up with the demand.

When the production system finally allowed some leeway, Magokichi loaned out 20 powered rice hullers free of charge to his relatives and let them earn fees from hulling. He wanted to be of some help to his extended family who were so poor that some had to run away under cover of night because they could not repay loans and were enduring difficult times. This was an example of Magokichi’s consideration for others, because he knew all too well the poverty of isolated villages and the harshness of agricultural labor.



A press conference with representatives from Cerezo Osaka

## Implementing Reform Leading Up to the Centennial of the Group’s Founding

# 1998-2012





Introduction of the Euro



Financial crisis after the Lehman Shock (2008)

#### HISTORICAL BACKGROUND

The aftereffects of the collapse of the economic bubble lasted far longer than expected, and the annual real economic growth rate of Japan in the latter half of the 1990s was limited to 0.8%. In 1997 an austerity budget giving priority to reconstruction of public finances was implemented. In April, the national consumption tax was raised from 3% to 5%, further worsening the economy. In July, the economy was dealt another blow by the outbreak of the Asian Financial Crisis. Stock prices and land prices tumbled, investment in private-sector plants and equipment showed no signs of recovery, and from that year into the next, one bank and stock brokerage after another went bankrupt, intensifying financial instability.

Following this, the dot-com bubble brought about a temporary improvement in the economy, but it was not until February 2002 that a broad-based long-term improvement appeared. However, with the uproar over the housing bubble in the U.S. and the increasing of exports to the BRICs and other newly developing economies as primary factors, there was sparse actual awareness of the favorable economy that continued over the following six years, and individual consumption remained sluggish.

Meanwhile, with the collapse of the housing bubble in the U.S. and downfall of the major investment bank Lehman Brothers Holdings Inc. in September 2008, the financial crisis spread and brought on a global-scale recession. The Japanese yen continued to appreciate against other currencies and the Japanese economy, which relied on exports, suffered major damage.

## Takehito Yamaoka becomes the company's 4th president

On June 19, 1998, Managing Director Takehito Yamaoka took office as the company's 4th president, and President Tadao Yamaoka became Chairman. Chairman Yamaoka, commenting on the purpose of the first change in presidency in 35 years, said that in order to pull through the turbulent period of the 21st century, "youthful strength, clarity of thought, and decisiveness" were necessary in management.

Incoming President Takehito Yamaoka, the eldest son of Tadao Yamaoka, was born in January 1959. He is the grandson of the founder, Magokichi Yamaoka. After graduating from the Faculty of Law at Keio University, he completed graduate studies at Yale University and received an MBA. After he joined the company in 1982, he gained experience in overseas business-related departments and successively held posts as head of the GHP Division and of the Customer Support Division. When he assumed presidency at the age of 39, he had the youthful strength suitable for leadership in the new age.

In his speech upon assuming his new post, President Takehito Yamaoka stated that he would set about working on three core issues.

First, he intended to lead the company in such a way that customers would be happy that they had purchased Yanmar products



Takehito Yamaoka delivering a speech upon assuming his new post as Yanmar's 4th president (1998)



With Chairman Tadao Yamaoka

and that had developed a relationship with Yanmar. In order to bring this about, the company would develop a system that would promptly provide products and services that appropriately reflect the opinions of its customers.

Second, for the company's employees, he intended to maintain an enterprise where they found meaning in their work. By making responsibility and authority clear, he would promote development of a business environment that would raise productivity and allow employees to work with latitude and a sense of fulfillment.

Third, it was his aim to prioritize distribution of management resources in order to strengthen high productivity. The company would promote operational innovations that would make the organizational structure more compact and make efficient use of information and technology.

Of the three, President Yamaoka placed greatest emphasis on the first. The company had always set out its operating principles with customer satisfaction (CS) as its core management policy, that is, customer orientation as the focus of product development and production. However, as President Yamaoka grasped the situation, in the long run, it was difficult to free oneself from a manufacturer-centered stance. For example, was a lineup of products in units of 1 hp or 2 hp actually responding to the demands of customers? Was it possible that development and production functions overlapping between groups were factors that were not responding to customer needs when it came to costs? With apprehension regarding such issues, President Yamaoka aimed at creating a system that could promptly provide goods and services that accurately reflected customer opinions. He firmly resolved to approach the customers as close as possible to grasp their views and ways of thinking and to carry out management reform based on that.

However, despite setting off in high spirits, he soon encountered rough seas. Due to the previous years' recession, sales for fiscal 1998 declined 7% to 244.8 billion yen, the first drop in 5 years, and ordinary profits for the same period fell 72% to 900 million yen. Furthermore, on the occasion of the collapse of the bubble economy, Y.D. Finance, the company's finance subsidiary and Yanmar Agricultural Equipment's Yanmar Finance had suffered losses totaling 50 billion yen and a thoroughgoing response to those losses had been postponed.

Therefore, with the launch of the new tenure, drastic cuts were made. Special liquidation of these two companies was commenced.

Because the company and Yanmar Agricultural Equipment in the budget for the year 1998 took an extraordinary loss calculated at 40 billion yen, Yanmar showed a deficit of 22.5 billion yen and Yanmar Agricultural Equipment showed a deficit of 7.1 billion yen for the period.

This was the first step taken in the crisis, but after draining what had been festering for years, it was possible to push onward toward the original goals. In the presentation of the company's Business Management Policy for 1999, President Yamaoka hammered out a course of action called "Group Optimal Management," which was the start of structural reform.

The meaning of "Group Optimal Management" is to create a system which can make the most efficient allocation of managerial resources and establish goals within the Yanmar Group as a whole, manifesting the maximum effect. Until that time, the companies in the Group had taken measures to pursue expansion of their own individual profitability and efficiency through separate development, production and sales functions. As a result, duplication and overlapping of functions between companies and between divisions within companies had led to structural inefficiency.

Further, because each company within the Group supervised its own profits and losses, it grappled independently with cash flow, but by adding an overall supervision of the financial situation in the individual companies, it was possible to see cash flow in comparative terms. The overall view made it possible to know exactly how much profit was created by the capital poured into each enterprise and clarify the outcome, which in turn strengthened the Group's overall financial standing.

## Reform of operation processes through PDP

President Yamaoka himself took the lead by initiating the Product Delivery Process (PDP).

PDP utilizes three-dimensional computer-aided design (3D CAD), allowing every division to share data from planning and design to production and allowing various aspects of operations to proceed simultaneously and in parallel. This method of development allows a substantial shortening of the process from development to mass production. The distinguishing feature of this method is that it is not a tool for just one part of the process but can be



Announcement of the annual Business Management Policy





Design utilizing 3D CAD



A pleasure boat designed using 3D CAD

deployed throughout the entire Group.

President Yamaoka did not promote the PDP reform simply to make product development more efficient. By constructing an efficient flow of operations that unifies sales and service—in which the customer is the point of departure—with distribution, production, and research and development, the reform aims at raising the level of customer satisfaction and making it possible to carry out a reform of organizational structure that can adapt to change. President Yamaoka had come across the innovation when he noticed that Deere & Company, a business partner, had introduced this method and achieved unprecedented results.

In June 1999 the PDP Reform Office was established in the Biwa Plant, and the opening ceremony was the kick-off for PDP reform. Its goals were to reduce the lead time between the planning-design stage to the mass production stage by 50%, reduce the occurrence of quality issues, minimize costs, increase functions and added value to products, actively support sales and improve after-sale services.

Commencing in September of that year, pilot projects were selected in each company and trials began. Beginning in November, meetings to explain the PDP reforms and ask for cooperation were held with business connections in such fields as materials and parts. They began setting up the same 3D CAD system that the Yanmar Group used and a cooperative system was established.

It is true that there was some puzzlement among engineers who had long experience with 2D CAD. A certain period of time was necessary for an awareness of the significance and necessity of operation process reform to spread across the Group as a whole.

In Japan at that time, PDP reform was being introduced by only a few groups of enterprises including Yanmar. President Yamaoka persisted in his appeals regarding how making use of the system's advantage would be a major strength in separating Yanmar Group from its rivals.

On occasion, to make the system easy to understand, he compared it to the introduction of the bank ATM. When banks first introduced ATMs, there was a degree of confusion among customers, but as a result of their adoption, the long waits at the bank counters became unnecessary. Banks were able to carry on their operations more efficiently and reduce labor. He introduced this as a familiar and successful example of how process reform could bring advantages to both parties.

Only one product was completed during the year 1999 as a result

of the implementation of PDP reform. In 2000, however, that rose to 10 products, and even in the market, the system developed a good reputation. During this time, verification was carried out on all of the parts of all completed products. Results and issues were delineated and the accuracy of the system was enhanced. As a consequence, PDP reform steadily spread throughout the whole Group, and practical implementation in each product area proceeded at a rapid pace.

Further, accompanying the advance of PDP reform, this 3D data product information became indispensable in constructing the common information system shared throughout the Group. Accordingly, the company advanced the creation of the Product Data Management (PDM) system, which was put into effective use in 2002.

## Introduction of ROA as a management index

In the latter half of the 1990s, the internationalization of the world's economy moved forward and a global standard was rapidly introduced in Japan as well. Beginning with a Japanese version of the financial Big Bang, various forms of deregulation and relaxation of controls regarding business management were put into effect. In June 1997, as a result of the revision of the Antimonopoly Act, the ban on the forming of holding companies was lifted. From March 2000, listed businesses consolidated accounts and were required to disclose consolidated financial statements.

Taking into account this climate, the company set about a management reform aimed at improving the Group's overall performance as a global enterprise.

In the announcement of the company's Business Management Policy for 2000, President Yamaoka pointed out that while the company's main business held on to its market share within the top three of the respective businesses, profitability of those businesses was lower than that of competitors. Until that time, he indicated, there had been an emphasis on sales volume and numbers of units sold, and at times there had been a tendency to think that the more units put on the accounts the more profit would result. In actual fact, there was a tendency to invest more capital in equipment and facilities in order to increase production. As a consequence, however, the deterioration of the asset turnover brought about a conspicuous drop in profitability.

In order to remedy this situation, it would be necessary to improve asset management efficiency. To accomplish this, beginning in 2000 the company adopted Return on Assets (ROA) as a management index. It should be added that Return on Equity (ROE), which is often used as an index in management, was not appropriate for the company due to its small capitalization.

### Introduction of the in-house company system

Based on the principle of most appropriate management for the Group, the company put its energies into strengthening the makeup of the selection and focus of undertakings. The Group as a whole aimed for an organizational system in which each function of production, sales and development in each separate enterprise was uniform and was self-regulated with clarity of responsibility. The company itself started the process of structural reform by aiming at securing a sturdy enterprise and financial setup.

In March 2000, organizational reform was initiated and the system of in-house companies was introduced. Four types of companies were instituted: Industrial Engine Company (former name: Industrial Engine Division), Large Power Products Company (former name: Large Power Products Division), Industrial Machinery Company (former name: Industrial Machinery Division) and ES Company (former name: Energy System Division). In June of that same year, the system of Executive Officers was introduced and accompanying that, the head of each company was installed as an

Executive Officer.

Executive Officers were in charge of their respective companies, and Directors were in charge of assessing the businesses and corporate strategies of Yanmar as a whole. Those carrying out the business and those evaluating the business were divided, and the purpose of doing this was to rigorously promote responsibility and strict evaluation of the businesses.

The new performance evaluation was based on having each company prepare a statement of profit and loss, a balance sheet and a cash-flow statement, and then using these to manage and evaluate performance. Earnings targets were determined on the basis of financial indices including ROA, cash flow and non-financial CS indices. This system, which evaluated both the results and the process, indicated in numerical values the asset efficiency and return on investment that profit-loss management to date had insufficiently grasped, and it clarified the degree of achievement in business performance.

### Reorganization of sales companies

Organizational reforms extended to a radical restructuring of the company's sales organization.

As of 1999, the Group's sales companies were divided into specialty sales for each division, with a total of 19 companies nationwide: 12 marine companies, 5 construction equipment companies and 2 gas heat pump (GHP) air-conditioning system companies. These were

**System of in-house companies (2000.3)**

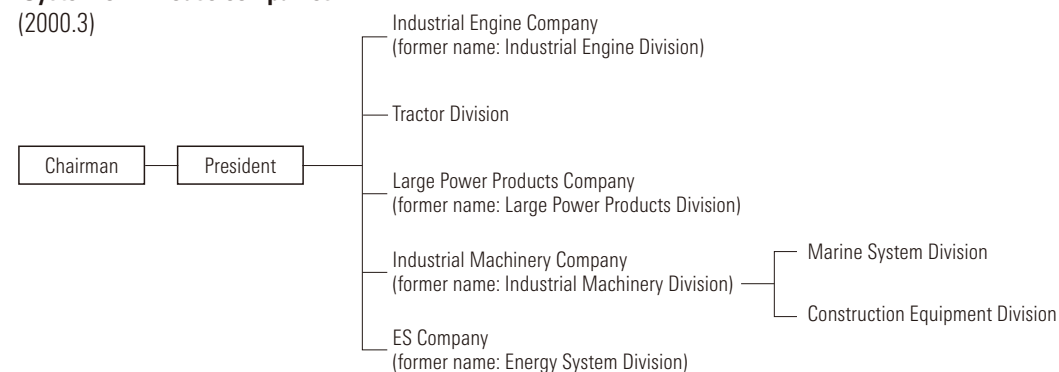

**Integrated sales companies in Yanmar Diesel Sales Company**

Marine sales companies	Construction equipment & Gas heat pump (GHP) air-conditioning system sales companies	General sales companies
Tohoku Yanmar	Yanmar Construction Equipment Tohoku	Tohoku Yanmar
East Japan Yanmar	Yanmar Construction Equipment Kanto Yanmar GHP Tokyo	Yanmar East Japan
Tokai Yanmar Hokuriku Yanmar Kinki Yanmar	Yanmar Construction Equipment Chubu Yanmar Construction Equipment West Japan Yanmar GHP Kinki	Yanmar West Japan
Chugoku Yanmar Sanin Yanmar Shikoku Yanmar	(Yanmar Construction Equipment West Japan Chugoku and Shikoku area)	Yanmar Chugoku and Shikoku
Central Kyushu Yanmar Nagasaki Yanmar Nippo Yanmar South Kyushu Yanmar	Yanmar Construction Equipment Kyushu	Yanmar Kyushu
<b>12 Companies</b>	<b>5 Companies/2 Companies</b>	<b>5 Companies</b>



all restructured as general sales companies dealing with all products over a wide area. While seeking to improve business efficiency, this new structure expanded and strengthened the sales network.

In June 1999, integration started with the Tohoku Yanmar Co., Ltd. (Sendai, Miyagi Prefecture), and together with the previously integrated sales companies in Hokkaido and Okinawa, 7 sales companies were created. Where there had been 130 outlets including branch offices, integration resulted in 110 outlets. As a result, gaps in each business's areas were eliminated and new prospects expanded for product markets.

Meanwhile, Yanmar Agricultural Equipment gradually began to move forward in its own integration in 1992. This involved integrating the 3 routes of retail, wholesale and agricultural cooperatives with branch office functions. This continued at a rapid pace from 1999 onward and with the establishment of Yanmar Agricultural Equipment West Kyushu Co., Ltd. in 2001, 30 companies were established.

Following that, with a view to strengthening the sales and service system through merits of scale and reduction of indirect costs, the company moved toward becoming a wide-area comprehensive sales business. It newly established Yanmar Agricultural Equipment East Japan Co., Ltd. and Yanmar Agricultural Equipment West Japan Co., Ltd. and by March 2004 it had established 12 companies nationwide.

## Carrying out the Yanmar Evolution Plan

In January 2002, the company put into motion the largest-scale management reform in the 90 years since its founding: the Yanmar Evolution Plan (YEP).

Soon after President Yamaoka assumed office, he set forth the line of thinking of "Group Optimal Management," in quick succession adopting the PDP reform and the ROA indicator, while introducing the in-house company system.

During the long period of economic growth, it might have been all right to overlook to some degree the inefficiencies of overlapping and decentralization of operations that accompany the expansion of the scale of an enterprise. However, with a deflationary trend in place and severe international competition building up, even minor inefficiencies could be ruinous. This series of measures was

an attempt at pruning the inefficiencies that did not lead to competitive strength and self-renewal of the company so that it could vigorously and agilely compete.

The measures yielded results quickly. ROA showed a favorable movement toward the target and by the end of the first year of the reforms, interest-bearing debt had, for the Group as a whole, been reduced by approximately 13 billion yen. However, the structure of the market and the industry shifted even faster than expected and a brief look around detected businesses forced into bankruptcy and businesses forced out of markets. President Yamaoka felt the company was under greater pressure day by day because the current pace of reform was insufficient.

President Yamaoka decided that the only way to realistically ensure continued development of the Yanmar Group was to carry out even more drastic management reorganization. When presenting the company's Business Management Policy for 2002, the final year of the mid-term three-year plan, he announced that the company would set to work on YEP.

YEP consisted of two components: a reorganization of the business system and making operations more efficient. To come right to the point, reorganization meant integrating production, sales and development. Achieving this entailed strengthening the "selection and centralization" that was called for at the introduction of the in-house company system and establishing "a system of clear responsibility, whereby each business maintained its own production, sales and development elements."

It was decided that accompanying this, once each business became self-sufficient, it would become a business unit company (i.e., independent enterprise) and Yanmar would evolve into a holding company. The holding company would draw up strategies for the whole Group and take on the role of checking the management of the business unit companies. The fundamental concept was that this would both maintain the unique character of the management of each company and allow it to better concentrate on operations.

On July 1, 2002, the company name was changed from Yanmar Diesel Co., Ltd. to Yanmar Co., Ltd. and it made a new start as a holding company.

There are two types of holding companies: a pure holding company and an operating holding company. Yanmar elected to become the latter at the initial stage. From the outset, it was anticipated



Announcement of initiating the YEP (2002)



The sign changed to Yanmar Co., Ltd.

that the energy system business and construction equipment business would at an early stage be turned into independent companies, but the engine business was a core component which influenced the predominance of each business. In terms of cost and quality, it had to constantly aim at being number one in the world. Accordingly, distinguished from the business unit companies which bore responsibility for earnings, the small engine, large engine and medium-size engine businesses were considered to be the centripetal force aiming for the Group's most-appropriate management, so they were left within the holding company itself.

In relation to the overseas business, in Asia, Europe and North America regional headquarter companies (RHQs) were established, aiming at a system with responsibility for devising and carrying out regional business strategy. Each RHQ functioned as a regional base for global financial management, logistics and distribution, while at the same time assuming a supporting role for efficient operations in the respective Yanmar overseas subsidiaries under their control.

The second theme of making operations more efficient took as its goal achieving cost competitiveness necessary to survive in a global market in which competition was intensifying. Due to the fact that cost issues were a serious problem common to virtually all of the businesses, this was an extremely significant reform within YEP.

First of all, it aimed at pulling together and integrating the development and production functions that were redundant and scattered throughout the Group into, as a principle, "one product, one factory," eliminating similar models and unprofitable models and getting rid of excess production capacity.

By means of this restructuring of production factories in connection with reorganizing the operating system, it was decided to close the Nagahama Plant and two other domestic production bases. Closing the Nagahama Plant, which for 60 years had continued operations as the central factory for small engines, greatly astonished people both inside and outside the company. At the same time, it clearly indicated that there would be no exceptions to the ongoing reforms.

In addition, with a view to reducing purchase expenses by 10%, in September 2002, the company shifted to a centralized purchasing system. In addition, the company integrated the sales companies, reducing costs by centralizing the Group's distribution function, moving to a merit-based compensation system, introducing shared

service in order to concentrate common operations between management sections and selling off real estate and securities that were not directly related to the core businesses. Among the real estate that was sold off was the Yamaoka Memorial Building, which had been constructed to commemorate the 70th anniversary of the founding of the company.

When considering the future business orientation, it was essential to consider the whole Group as a single enterprise and accurately grasp the scale of the company and the conditions of its operations. As a result of being able to clarify the system of responsibility for each business and its cash flow, the company commenced from 2004 to unify terms for the settlement of accounts of all subsidiaries into a substantial consolidated Group account. From this point forward, evaluation of performance was shifted to a consolidated account basis.

From approximately this period, the results of the implementation of YEP also began to appear in business results. Consolidated Group sales for 2004 rose above 500 billion yen by 7.7% to 502.6 billion yen, with ordinary profits for the same term increasing 35% to 16.5 billion. ROA, which had been 1.9% prior to YEP, increased to 3.3% and during that period, debt was reduced to 118 billion yen, approximately one-third of the previous amount.

We now turn to the details of the most important role that YEP played: the reorganization of each line of business.

### **Agricultural business**

Yanmar Agricultural Equipment Co., Ltd. reached its peak performance in 1996 and that was followed by a 6-year period of decrease in income and in profit. This resulted from a composite of factors, such as maturation of the market, a drop in the prices of rice and vegetables and the economic slump. Under YEP, major restructuring was implemented in each business.

In July 2002, Yanmar Agricultural Equipment became a 100% subsidiary of Yanmar. Tractors, which were its key products, were produced at the Kinomoto Plant and the Ibuki Plant of Kanzaki Kogyokoki Mfg. Co., Ltd., development was done at Yanmar's Tractor Division while sales were under the management of Yanmar Agricultural Equipment. Further, OEM business for Deere & Company and other companies outside Japan was under Yanmar's control. The process began by gathering these various functions, which were widely dispersed, and speeding up the decision-making process.





Tractor assembly lines



Yanmar Agricultural Machinery Manufacturing (2002)



Inauguration ceremony of Yanmar Agricultural Equipment Sales (2009)

A tractor division and an agricultural machinery division were set up within Yanmar Agricultural Equipment. At the same time the tractor line at the Kinomoto Plant was integrated into the Ibuki Plant, and the latter became the parent production site for tractors and tractor transmissions under the newly established Yanmar Agricultural Machinery Manufacturing Co., Ltd. Following that, in July 2004, the construction equipment production business (Fukuoka Plant) was separated from Seirei Industry Co., Ltd. and Seirei Industry became a company specializing in the production of agricultural machinery other than tractors, such as combines and rice transplanters.

Yanmar Agricultural Equipment took these 2 newly established companies under its umbrella. Formerly concentrated at Yanmar's Maibara Research & Development Center, the tractor sections of the Agricultural Machinery Development Department were moved to Yanmar Agricultural Machinery Manufacturing and the combine and rice transplanter sections were moved to Seirei Industry's Okayama Plant. By doing this, the respective development, production and sales components of both the Tractor Division and the Agricultural Machinery Division were unified.

Further, the agricultural facilities sections of Yanmar Agricultural Equipment were split off to form Yanmar Green System Co., Ltd. in February 2008.

The agricultural machinery sales companies had been repeatedly consolidated and reorganized since the early 1990s, and in December 2008, with the exception of the 2 companies in Hokkaido and Okinawa, the other 10 wide-area sales companies were combined, establishing Yanmar Agricultural Equipment Sales Co., Ltd. with approximately 400 outlets and 3,700 employees.

In February 2009, Yanmar Agricultural Equipment was merged into Yanmar. The purpose in doing this was to improve agricultural machinery business profits and advance overseas business. More than a half century after its founding, bearing the same Yanmar name as it led the agricultural machinery industry and made major contributions to the mechanization of agriculture, the company had, for the present, fulfilled its role.

In addition, in January 2014, Yanmar Agricultural Equipment Sales merged with Hokuto Yanmar Co., Ltd. which had been responsible for the Hokkaido area, and they were reorganized as Yanmar Agri Japan Co., Ltd.

### Marine business

In March 2000, preceding implementation of YEP, Yanmar took over control of the production of medium marine engines and compressors from the affiliated company Showa Mold & Engineering Co., Ltd. The latter company's factory became Yanmar's Tsukaguchi Plant (Tsukaguchi-honmachi, Amagasaki, Hyogo Prefecture). And with the closing of Yanmar's Nagahama Plant in March 2004, production of small marine engines was transferred there, integrating small and medium-size engine production at the Tsukaguchi Plant.

In addition to the considerable reduction in the number of people gaining employment in the fishing industry added to the collapse of the bubble economy, there was little demand for replacement purchases of the highly durable FRP boats and therefore production slumped. Yanmar Shipbuilding & Engineering Co., Ltd. was inevitably forced to downsize its operations. In 1995, the Tohoku Division was closed, followed by the main office plant in Okayama in 2002, integrating everything at the Oita Division. The reason for selecting the Oita Plant instead of the plant at the Okayama head office was that the Oita Plant had the newest equipment and facilities and it could manufacture everything from mass-produced small boats to large fishing vessels.

There was also a major change in the sales system. In connection with YEP, in July 2002, Yanmar Marine System Co., Ltd. was established. It began as a sales company with control of the whole domestic marine market and the overseas marine engine market, centered on Asia. In September 2004, the marine sections of the 6 nation-wide general sales companies were consolidated into a single marine sales department.

In July 2002, the company set up Yanmar Marine International B.V. (abbr. YMI) inside Yanmar Europe B.V. in Almere, The Netherlands, which commenced operations the next year. Established to conduct sales and service of marine engines, YMI was also entrusted with decision-making authority concerning product development and production. In addition, it supervised worldwide operations functions for pleasure boat engines. Placing this strategic base in Europe, which is a major market, as well as employing local personnel in top management positions were firsts for the Yanmar Group.

However, following the Lehman Shock in September 2008, the world marine market slowed rapidly. Using this as an opportunity to seek a synergy effect in management resources from both commercial and pleasure boat engine businesses, the company



Tsukaguchi Plant (2000)



Cell manufacturing system at Tsukaguchi Plant



The Oita Division of Yanmar Shipbuilding &amp; Engineering



Yanmar Marine International at a boat show in Dusseldorf



established the Marine Operations Division in March 2010 to consolidate overall operations at home and abroad.

### Construction equipment business

In July 2002, Yanmar's Construction Equipment Division became the Construction Equipment Company. In addition, a series of production transfers were conducted among Group companies in Japan, aimed to establish Seirei Industry's Fukuoka Plant as a specialized factory for producing construction equipment.

First, in May 2003 the wheel loader, which had been produced at Kanzaki Kokyukoki was moved to the Fukuoka Plant. In June, production of the power tiller at the Fukuoka Plant was moved to Seirei Industry's Okayama Plant and production of the crawler tractor was moved to Yanmar Agricultural Machinery Manufacturing in August. In July of that following year, the construction equipment production section at Seirei Industry was divided up, and Yanmar Construction Equipment Co., Ltd. was established, with the headquarters at the Fukuoka Plant. In September, Yanmar's Construction Equipment Company split off and merged into Yanmar Construction Equipment.

In the sales category, in March 2004, the construction equipment sections separated from the 6 nation-wide general sales companies and merged to form Yanmar Construction Equipment Sales Co., Ltd. which specialized in the sales of construction equipment.

By integrating development, production, sales and service into Yanmar Construction Equipment and Yanmar Construction Equipment Sales, it was possible to promote a system that was both efficient and speedy. Following that, in March 2011, in order to speed up production development that responded to the global market and meet market demands, Yanmar Construction Equipment Sales was merged into Yanmar Construction Equipment, completing a fully integrated construction equipment business system.

### Energy system business

In March 2000, prior to YEP implementation, the GHP Division, which was in charge of the air-conditioning system business, was integrated with the Industrial-use Systems Division, which was in charge of the power-generation systems business to found ES Company (Energy System Division), creating an operations structure that offers comprehensive energy solutions.

In April of the same year, Yanmar Energy System Mfg. Co., Ltd. was established in Saidaiji, Okayama, for the purpose of producing GHPs and in August its factory was completed. Until that point, assembly of GHPs had been entrusted to Nishiyodo Air Conditioner Co., Ltd. and production was moved to the new factory. The factory was then expanded and, in May 2002, production of micro cogeneration systems commenced.

As things evolved, in March 2003, ES Company and the energy system sections of the 6 nation-wide general sales companies were integrated to form Yanmar Energy System Co., Ltd. in Kita-ku, Osaka. Yanmar Energy System Mfg. Co., Ltd. was placed under its umbrella. In this way, a fully integrated energy system production, sales and development system was established.

In April of the same year, a second plant, which produced power generation equipment, was completed. With this added to the first plant, which produced GHPs and micro cogeneration systems, the company had the capacity to produce all of its main products. Further, within the category of power-generation equipment, in September 2007, Kohrin Engineering Co., Ltd. became a fully-owned subsidiary of Yanmar Energy System with the aim of strengthening operations for the integration of design, production and testing of regular-use and emergency-use generators.

Further, Yanmar had from an early stage in the fields of air-conditioning and power generation worked to industrialize maintenance, and on the occasion of the establishment of ES Company, the two maintenance sections were integrated. At the same time, the company had worked toward institutionalizing its partner companies in charge of service, maintenance and construction work, and so "Hapon-kai" (trans. *Heat Pump Association*) was established to cover the air-conditioning field and "ES-kai" (trans. *Energy System Association*) to cover the power-generation field.

In 2002, the company began the "YES Partner" contract maintenance system for GHP users. This system is a long-term contract for regular inspections, replacement of expendable supplies and repairs of malfunctions. By using a remote surveillance system, which aims at checking and servicing equipment before it breaks down, rather than repairing it when it has already broken down, this system is raising customers' trust. At present, in Japan and overseas, some 4,500 pieces of equipment are under continuous monitoring and this has become one of Yanmar Energy System's main businesses.



Inauguration ceremony of Yanmar Construction Equipment (2004)



New product releases at the Yanmar Construction Equipment Convention (2004)



Yanmar Energy System Mfg. (2000)



GHP production lines



Inauguration ceremony of Yanmar Energy System (2003)



Remote Surveillance Center

### Component business

Under YEP, Kanzaki Kogyukoki passed on all of its machinery production to the related business bodies. In July 2002, the Ibuki Plant, which produced tractors, merged with the tractor production sections of Yanmar at the Kinomoto Plant and formed Yanmar Agricultural Machinery Manufacturing Co., Ltd. Following that, rice transplanter production was transferred to Seirei Industry's Okayama Plant and the wheel loader production was shifted to its Fukuoka Plant.

Meanwhile, in April 2003, the development and sales of marine gears were transferred from Yanmar and in October the hydraulic equipment (large hydrostatic transmissions) development and production at the Nagahara Plant were transferred to Kanzaki Kogyukoki.

As a result of this reorganization, the business of Kanzaki Kogyukoki was specialized to produce components, i.e., machine tools, gears, hydraulic equipment, and transmissions. While the scale was reduced, Kanzaki Kogyukoki's high technological capability contributed to the Group and energetically broke new ground in the overseas market.

In April 2004, the company purchased land adjacent to the head office and built a new factory. Accompanying that, in September, Kanzaki closed its Amagasaki Plant, further advancing the efficiency of the production system.

### Industrial engine business

As an operating holding company, there remained within the company the engine business which had been the base of the enterprise since its founding. On the occasion of the launch of the new system, under the Engine Division, the company placed the Small Engine Factory, Precision Equipment Factory and Large Engine Factory (including the production of medium engines). In June 2005 these became the current Power System Operations Division and Large Power Products Operations Division.

With the institution of YEP, even within the small engine business, in order to create a suitable production system to reduce excessive production capacity, the company settled on a large-scale transfer plan based on the principle of having one factory for one product. The focus of this plan was decentralization of the Nagahama Plant, which for a long time had served as the mother factory of small engines, producing a wide variety of products, and the halting of all production at



The I-HMT transmission



The head office's new plant at Kanzaki Kogyukoki (2004)



Nagahama Plant ceases production (2004)

that factory. At the time, there were some 20 production lines at the Nagahama Plant; ultimately all of them were to be transferred to seven other factories either in Japan or overseas. A major reexamination of the production items of each of the related factories was also implemented.

In June 2003, small and medium marine diesel engine production was moved to the Tsukaguchi Plant. Production of the *yokosui* horizontal water-cooled engine and L model air-cooled diesel engine was transferred between October and February of the following year to the Yamamoto Plant. This brought to an end the production activity at the Nagahama Plant, which had lasted 62 years since the founding in 1942. During that time, the plant had produced more than 6 million *yokosui* engines and over 1 million L model engines. In addition, approximately 350 employees were redeployed in the Group's factories in the Lake Biwa area.

From August 2005 through October of the following year, the production of gasoline engines and *yokosui* engines as well as L model engines was transferred from Yamamoto Plant to the Kinomoto Plant. The Yamamoto Plant became a factory specializing in die casting and processing.

The domestic production of *yokosui* engines, which had been the effective starting point of the company as well as supporting the enterprise's development, came to an end in December 2008. P.T. Yanmar Diesel Indonesia and Thailand's Yanmar S.P. Co., Ltd. succeeded to that line of production. Further, because production of L model engines, for which the biggest market was Europe, was transferred to Yanmar Italy S.p.A. in March 2011, the only factory in Japan where the company still produced small diesel engines was the Biwa Plant, which produced *tatesui* vertical water-cooled diesel engines.

During this period, the Biwa Plant was both delighted and overwhelmed with work as demand for increased production continued. In Europe and North America, which were in a ferment over the housing bubble, sales of small construction equipment were increasing, so there was a strong demand for vertical water-cooled diesel engines. There was also an increase in orders for trailers with refrigeration units and varieties of machines that could meet exhaust standards. The expansion of the Chinese market also raised demand for *tatesui* engines.

Through OEM sales, business clients for *tatesui* engines increased, which led to a rise in the number of models produced. In order to raise the Biwa Plant's capacity to cope with small quantities of a



Production lines transferred to P.T. Yanmar Diesel Indonesia



large variety of models, the company prepared a standard model for each type of machine produced, such as tractors and mini excavators, and this made it possible to shorten the time necessary for developing individual models as well as to reduce costs. Through a careful review of the manufacturing process, including changes in the work regime and thoroughness in estimating malfunctions, the 1998 production of 210,000 units was raised to 370,000 in 2006, and plans were made for further increases to 500,000 units. However, due to the Lehman Shock in the U.S., the production target of 480,000 units for 2008 dropped to 340,000 units. That was a heavy blow, but domestic demand rose thereafter and gradually signs of a recovery became apparent in Europe, America and China, and production gradually improved.

### Large marine engine business

On the occasion of the start-up of the Large Engine Company in March 2000, the Industrial Systems Division, including power generation systems, was separated and transferred to the ES Company, and the former's focus from that point onward was on large engines. Later, the name was changed to Large Engine Factory and in June 2005 this became the current Large Power Products Operations Division.

From the mid-2000s, boat construction thrived and the large marine engine industry came to life. This was due to the fact that newly developing nations such as China were coming to the fore and the volume of world trade was increasing. The expansion of the various countries of Asia in the shipbuilding industry was remarkable. Japan had maintained its position as the top shipbuilder in the world from 1956 onward, but in terms of total orders in 1999, it came in second to South Korea and was further passed by China in 2006. The map of distribution of economic power was totally redrawn.

Following 1990, when the shipbuilding industry extricated itself from a long-term recession, Yanmar shifted its objective from obtaining market share to emphasizing customer share, expanding the solution business to respond to the needs of individual ship owners, shipyards and other such clients. This effort was further advanced in 2005 when sustained activities aimed at improving Life Cycle Value (LCV) were introduced.

Raising LCV meant increasing to the greatest extent possible the value for the purchaser of a vessel, beginning with the placement

### Life Cycle Value-> Development- Production- Sales- Service (YE) : an integrated system in the service of the customer

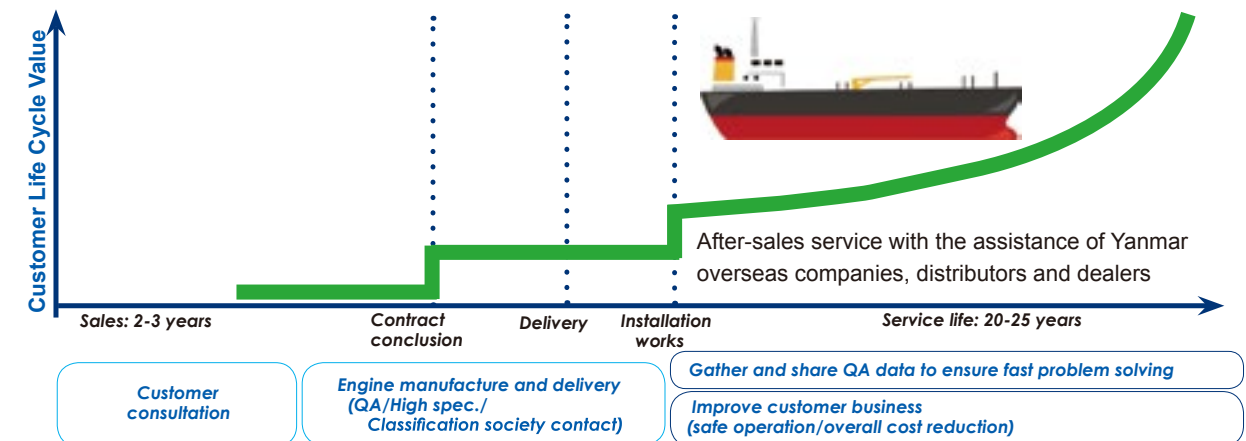

of the order, continuing through the installation of the engine and the completion of construction, and lasting through its 25 to 30 year lifetime until it is retired from service. The company united development, production, sales and service departments to improve long-term reliability and durability and implement low-cost operation in order to gain and retain customer trust.

Engine development based on LCV improvement, with an assist from increasing demand, led to an annual increase in shipments, and in 2008 the company produced 2,467 units, the largest number since operations began. In particular, the 6EY18 marine auxiliary engine, which was developed in May 2006 on the basis of meticulous market research, became immensely popular because it required little time and effort for maintenance and it had high fuel efficiency, which lowered running costs some 40% (when used over a 25-year period).

During this period, in order to respond to this brisk demand, the company took measures to enhance product capacity by investing in the Amagasaki Plant to install more machine tools and increase the number of personnel. In December 2007, in order to realize development of products that would cope promptly with the latest exhaust emission regulations, the company constructed a testing facility within the factory. In recent years, this facility has been carrying out advanced product research and development leading to safe ship operations and cost reductions. One example of this is



A testing facility at the Amagasaki Plant (2007)

an advanced ship-safety management system, in which the conditions of an operating engine are monitored by onboard sensors that also allow immediate transmission to the shore of data regarding possible abnormalities.

## Deployment of YWK activities throughout the Group



Yanmar Way by Kaizen (YWK)

After introducing the Yanmar Production System in 1976, based on the Toyota Production System, the company has taken measures to make improvements with the main focus on eliminating waste.

In the midst of reorganizing operations through YEP, production system strengthening activities were further deepened, leading to a company-wide program of action beginning in March 2004 called Yanmar Way by Kaizen (YWK).

The goal of YWK is to strengthen corporate operations so that the company can provide customers with what they want, at the time they need it, and in the quantities they require. This kaizen program set goals for quality (Q), cost (C), and time (T). Under quality, the program aimed at lowering the incidence rate of claims and defects. Under cost, its goal was reducing production costs and raising productivity. Under time, it focused on shortening the lead time between reception of an order to shipping and the stock turn-over period.

In addition to the energetic activity in the development, production, sales, distribution, service and general affairs departments and with the assistance of cooperating manufacturers, regular reports were provided on operations and performance. On the basis of the YWK activity maps for each year, an evaluation is made and important strategic policy points are established for the next year in order to constantly make improvements. Further, in the field of human resource development, the company is actively carrying out kaizen training and networking events.

YWK activities have also spread overseas to related companies in Asia, America and Europe and in March 2014 the company held the first YWK Global Convention in Osaka. Approximately 400 personnel from Group companies in Japan and overseas attended. Together they presented a total of 648 improvement proposals and 21 teams presented actual case studies.



The awards ceremony at the first YWK Global Convention (2014)

## Establishing a global tri-polar research system

In order to survive in the severely competitive global market of the 21st century, and to actively contribute to creating products and systems that preserve the global environment, it is absolutely essential to strengthen even further the company's research and development capabilities. While strengthening R&D facilities in Japan, the company created bases overseas as well, with the goal of building a system that can compete around the world.

The site of the Yanmar Kyoto Research & Development Center, which until then Yanmar shared with Yanmar Agricultural Equipment as a base for R&D, was included in an expressway interchange plan site and it became necessary to relocate it. Seeing this as a favorable opportunity, the company decided to build a new research center that would suit the current age.

The new research center was built in Maihara-cho, Sakata-gun, Shiga Prefecture (present-day Umegahara Maibara, Shiga Prefecture), close to the Biwa Plant, a site measuring 41,700 square meters. The construction of this new center, called Yanmar Research & Development Center, began in July 1998 and was completed in January 2000. The facility carries out basic engine research as well as testing and research on low-emission high-efficiency engines, product development including agricultural machinery and equipment and, under the banner of strengthening underlying technology in such areas as hydraulics and electronics, aims at efficiency and increased speed of development.





Yanmar Research &amp; Development Center, Maibara (2000)

Together with the Biwa Plant, the center attaches great importance to harmonizing with the surrounding environment, and efforts were made to make the burden on the environment as light as possible. Equipment was installed to very efficiently eliminate dust in emissions that are generated during testing and to reduce as much as possible noise, vibration, atmospheric pollution and smells. Air-conditioning is implemented with eco-friendly GHP air-conditioning systems and rainwater is collected for use in coolant, water sprinklers and toilet draining. As a research base that gives serious consideration to the environment, which is the core of Yanmar Group manufacturing, the center became capable of producing new technology for the world in the 21st century.

In January 2008, the company built the Yanmar Kota Kinabalu R&D Center Sdn. Bhd. in Kota Kinabalu, Sabah, Malaysia.

The reason for choosing Malaysia as the first overseas research base was that palm oil, which is the raw material for fatty acid methyl ester (FAME) biodiesel fuels, and tung oil are easy to obtain there. The original aim was to carry out durability tests on diesel engines suitable for 100% FAME and investigate and analyze the effect on lubricating oil.

Experimental tests for the use of FAME with cogeneration sys-



Yanmar Kota Kinabalu R&amp;D Center (2008)



Palm tree fruit



Undiluted palm oil

tems in the U.K. and India are also carried out under the supervision of this center. In the future, looking at Asia in general, the center has the potential for playing an international role in developing biomass-use technology and in conjunction with Yanmar Research & Development Center, it will serve as a base for the transmission of environment-related information.

In June 2011, the company established another R&D base in Europe. The Yanmar R&D Europe S. R. L. was opened in Florence, Italy.

Research is being carried out at this facility on renewable energy and smart grids as well as on system regulators and simulations for operations electrification. In particular, the Tuscany region of Italy, where this base is located, has high-level research universities and an outstanding research environment.

As global energy information dramatically changes, Yanmar R&D Europe is actively working toward developing ties with universities, research institutions and high-tech venture enterprises, doing collaborative research, gathering information, and conducting industrial design research.

In this way, the company has established a global R&D system with the common theme of effective energy use in the three poles of Japan, Asia and Europe.

## Formulating an environmental vision and technological suitability

Between the adoption of the Kyoto Protocol in 1997 and 2005 when it took effect, the enactment of the Basic Law for Establishing the Recycling-Based Society and the reorganization of the Environment Agency into the Ministry of the Environment, the number of businesses actively engaged in environmental preservation has risen, and concern about environmental issues has increased in the official and private sectors.

In May 2005, the company formulated the Yanmar Group Environment Vision 2012, establishing concrete environmental goals for what it should achieve by 2012, toward significantly enhancing energy use. This represents the Group's dedication to fulfilling its Corporate Social Responsibility (CSR) and its promises to its various stakeholders.



Yanmar R&amp;D Europe (2011)

In April 2011, taking into account the actual situation of this vision and social changes that resulted from it, the Group's Environmental Vision 2020 was formulated. The Group's environmental activities were classified into four broad themes: preventing global warming, contributing to an environmentally sustainable society, reducing and controlling environmentally hazardous substances, and working on biodiversity. For each of these, new courses of action were established.

**Group's Environmental Vision 2020**

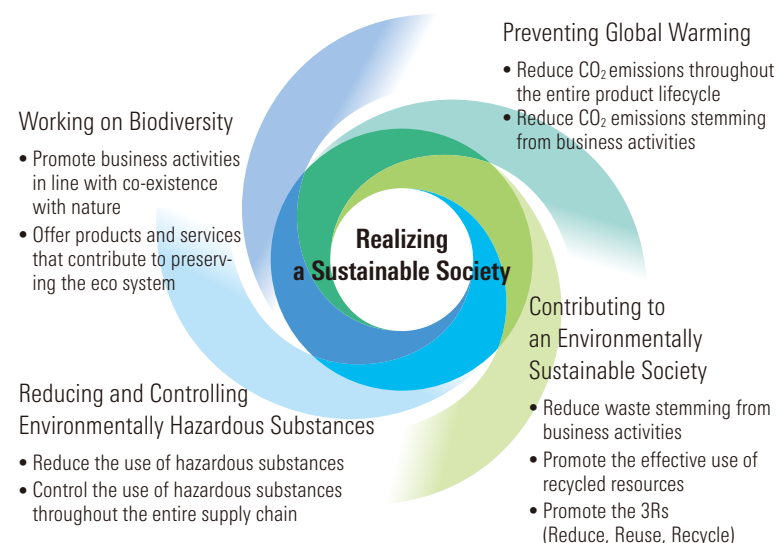

From *Environment and Society Report* to *Corporate Social Responsibility Report*

From 2002, in order to spread information about the Group's environmental conservation activities, the company drew up an *Environment Report* and posted it on the company's website. In 2007, this was revised as an *Environment and Society Report* and was published in print form. After another three-year preparation period, it was renewed in 2010 as the *Corporate Social Responsibility Report*.

Among the business activities that take concern for the environment as their base, it is not surprising that the Yanmar Group focuses on developing technology that can contribute to environmental conservation and developing products that make efficient use of energy. In this regard, let us touch on the environment-oriented products and technology which Yanmar's businesses have created that have succeeded in meeting strict standards.

**Strengthening small and medium engine environmental efficiency**

Regulations for diesel engine emissions have been successively toughened. Integral to meeting these standards has been technology that optimized performance by electronically controlling the amount of fuel injected and the timing of the injection. Playing major roles in establishing this technology were the integrated production of fuel injection pumps and nozzles, which the company had advanced since 1933, and electronic governing technology, which the company had begun to research and develop as early as the first part of the 1980s.

With the vertical engines, the company equipped the TNV series (6–72 kW), which first went into production in 2002, with a newly developed distributor type fuel-injection pump to reduce discrepancies in injection amounts and injection timing. The following year, this obtained EPA (U.S. Environmental Protection Agency) Tier 2 emissions certification. Further, in 2006, by introducing an electronic governor which could fine tune the injection amounts, the same series was certified under the EPA Tier 3.

Meanwhile in 2005, in the small and medium marine engine field, by combining an electronic governor with an electronic control hydraulic timer, which controlled not only the injection amount but also the appropriate injection timing, the company put on sale the 6LY3 marine engine series (279–353 kW) for the overseas pleasure boat market. In 2008, the company's 6CX530 (390 kW), which was the first equipped with a common-rail fuel-injection system (CRS), also received EPA Tier 2 emissions certification.

CRS, which allows optimal injection of high-pressure fuel by the opening and closing of a solenoid valve, is a cutting-edge technology that will be indispensable in responding to future regulations. The CRS is superb in lowering exhaust emissions and reducing fuel cost and vibration noise, making it superior to the company's unique distributor type fuel injection system with an electronic governor, but its high cost presented an obstacle.

However, because CRS, which had become mainstream in motor vehicle diesel engines, was unavoidable as a future technology, it was decided to consider it as an option. When the stage of full-fledged development was reached, it was decided that mass production of CRS would inevitably lead to lowering the costs and that the company would introduce the system into vertical industrial diesel engines.

The 4TNV94HT engine (69.8–88.4 kW) equipped with this sys-



A 4TNV98 vertical engine



EPA Tier 2 emission certification

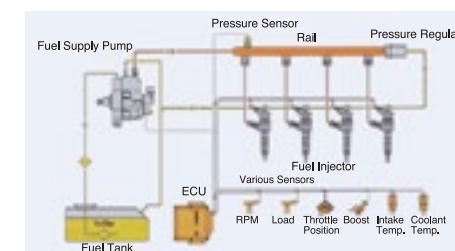

Common-rail fuel-injection system (CRS)





A 4TNV88C certified under CARB and EPA Tier 4 emission regulations

#### EPA regulation (19–37 kW Tier 1–4)

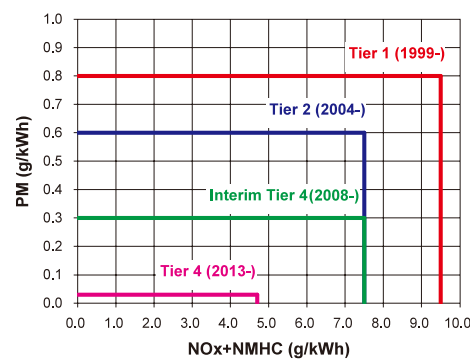

tem met the EPA Tier 3 and in June 2010 mass production began.

In addition to CRS, a newly developed diesel particulate filter (DPF) was also installed in the 4TNV88C engine (35.5 kW). DPF is a filter which collects particulate matter (PM), achieving a major reduction of PM in emissions to one-tenth. On the introduction of the DPF as a new device, together with analyzing how machinery is used, an evaluation was carried out on the assumption that the equipment was used in extreme conditions such as at high altitudes and in cold districts. This enabled enhancement of product versatility. The 4TNV88C which was developed in this way became the first engine in the 19–56 kW class to obtain the strict California Air Resource Board (CARB) Tier 4 and the EPA Tier 4 in 2012.

In June 2013, it became the first engine (in the 19–56 kW class) to be certified under Swiss Federal Office for Environment's Ordinance on Air Pollution Control (OAPC), the world's strictest regulations on diesel engines, which controls not just the mass of particulate matter (PM) but also particle numbers (PN).

#### NOx emission control by IMO

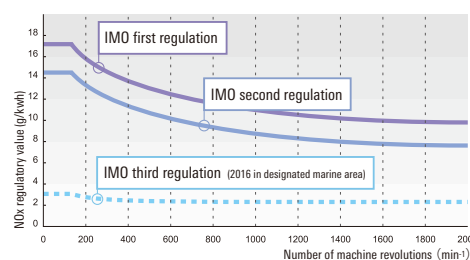

#### Strengthening large engine environmental efficiency

From 2005, the company has developed engines on the basis of improving LCV. The 6EY18 marine auxiliary engine, which was the first engine developed under this concept in 2009, was the first domestic marine engine to meet the International Maritime Organization (IMO) Tier 2 NOx emission limits.

That same year, the 6N18AEV engine, equipped with Yanmar's original electronic unit pump (EUP), was put on sale. By means of



The launch of the 6EY18 marine auxiliary engine (2006)

electronic control, it was possible to reduce fuel consumption while also raising environmental performance. Moreover, because it did not require high-pressure fuel accumulator parts, its greatest merit was that replacement parts were the same as previous machine varieties. This engine was awarded the Marine Engineering of the Year Award for 2009.

The next-generation marine model to attract attention was an electric propulsion system-equipped ship, one in which the propeller was not directly driven by an engine but actually an electric motor, in its turn powered by an auxiliary engine. In 2002, the company delivered the power-generation engine for the first electric propulsion ship *Sensho*, a coastal merchant vessel. Following that, the company provided an engine for the *Dai Hachi Shohei Maru*, the first deep-sea long-line tuna fishing boat, equipped with an electric propulsion system, which received the Marine Engineering of the Year 2004 Special Award.

#### Expansion of energy system products

As concerns spread regarding environmental protection and resource issues, all possible efforts were poured into cogeneration systems and the development of new GHP air-conditioning systems.

In the category of cogeneration systems, in October 1998, the most compact domestic item, YCP9800 micro gas cogeneration system, "E Combi" (9.8 kW) was put on sale.



*Dai Hachi Shohei Maru*, a long-line tuna fishing boat



The YCP9800 micro gas cogeneration system  
(1998)

Small gas cogeneration systems were already on the market, but they required frequent maintenance. Equipped with a gas engine for GHP use, Yanmar's model provided a long maintenance interval. The reason for entering the market with a 9.8 kW-type was that, because it was less than 10 kW, it could be easily handled without an operator who is an electric works specialist with qualifications. This product received the Energy-Efficient Machinery Award from the Japan Machinery Federation (JMF).

Following this, micro gas cogeneration systems achieved various advances.

In 2002, the CP22V (22 kW), which could be installed in a set of as many as six units, went on sale. Even in facilities where the need for power or heat varied according to the day of the week or the time of day, this product could operate efficiently by automatically switching the number of units according to the load.

The general generating efficiency of micro cogeneration was at that time about 20%, and the CP10VB (9.9 kW) equipped with a high-compression-ratio miller cycle engine and which went on sale in 2004, reached a generating efficiency of 31%. The maintenance interval which had formerly been 6,000 hours was extended to 10,000 hours. The CP25VB (25 kW), which went on sale in October 2004, achieved 33%, the world's highest electric power efficiency rate for micro cogeneration.

With the merits of multiple installations and improvement of generating efficiency, the company's cogeneration systems sold favorably, gaining an overwhelming share of the market.

In 2007, the company put on sale the CP25VB2 (25 kW) micro biogas cogeneration system which could make use of the digestion gases emitted by the residue of sewage treatment plants, domesticated animal excrement treatment plants and food-processing plants. With use of 6,000 hours per year to obtain electric power and heat, compared with the use of electric power and fossil fuels, emissions of carbon dioxide could be reduced by approximately 70 tons. In 2011, sixteen units were installed in the Saga Sewage Treatment Center and the number of operating units is being adjusted to meet the amount of digestion gas produced.

Meanwhile, in 1999, the E series of GHPs was put on sale, which simultaneously reached low exhaust emissions and high energy-saving efficiency. NOx emission volume in the previous series had been 300 ppm and this was reduced to 100 ppm. The maintenance interval



Saga Sewage Treatment Center (2011)

was extended from 6,000 hours to 10,000 hours. Coefficient of performance (COP) was improved and noise was reduced considerably.

In 2001, YNZP560FX, which used the new refrigerant R407C, with a zero ozone depletion coefficient, was put on sale. This was successful in reducing the consumption of gas by 20% and in reducing NOx exhaust by 40%.



The YNZP560FX air-conditioning system (2001)

## Reorganization of the American and European businesses following the Lehman Shock

Until this point, engines for pleasure boats in the North American market had been manufactured by Yanmar Manufacturing America Corporation (abbr. YMA) and sales had been conducted by Yanmar America Corporation (abbr. YA). However, in 2003, the marine department of YA was spun off and established as Yanmar Marine USA Corporation (abbr. YMU), allowing it to strengthen sales by linking production and sales.

In 2006 Yanmar Agricultural Equipment formed an alliance with MTD Products Inc., manufacturer of riding lawn mowers, and established a joint venture to sell compact utility tractors (CUTs). In 2007, Yanmar established Yanmar Agricultural Machinery America Corporation (abbr. YAMA) in order to develop, produce and market





Yanmar America

CUTs. Using MTD's brand and Yanmar's brand, the venture began to produce and sell tractors under the Cub Cadet Yanmar brand.

However, in the summer of 2007, the U.S. housing market began to sour and the subprime mortgage crisis erupted. In September 2008, the Lehman Shock dealt the U.S. economy significant damage, leading to a global financial crisis and recession.

The favorable trends that had been sustained in the North American market rapidly lost momentum and a reorganization of the Yanmar Group's operations there became inevitable. In July 2009, YMA, YMU and YAMA merged into YA, and marine engine manufacturing was transferred to the Tsukaguchi Plant.

As a result of the Lehman Shock, the market in Europe also shrank rapidly. Compared with the peak in 2007, demand for small construction equipment fell to one-third. In France, the partner Ammann Group Holding AG in the Ammann-Yanmar S. A. S., which had been formed to produce and sell mini excavators, indicated that under the circumstances it intended to dissolve the partnership. Yanmar Construction Equipment acquired the stock held by Ammann and in 2010 it made it into its fully-owned subsidiary, changing the name to Yanmar Construction Equipment Europe S.A.S. (abbr. YCEE).

While the Lehman Shock dealt it a heavy blow, Europe was and still is the world's largest market for small construction machinery. Yanmar Construction Equipment Europe grappled with achieving improvements in production efficiency and focusing on the fine details of sales and service, and today it is working to extend its market share even further.

### Speeding up expansion of operations in the Chinese market

Around the year 2000, newly developing nations showing particularly strong economic development included Brazil, Russia, India and China and from the initials of these countries' names came the general term BRICs. By far the most rapidly growing was China. In 2008, China recorded an economic growth of 14.2%, and in 2010 its nominal GDP passed Japan to take second place in the world. Its enormous potential attracted attention from around the world and Yanmar carried out operational activities aimed at meeting the demand.

In August 1999, a new plant was completed in Wuxi, Jiangsu Province and Yanmar Agricultural Equipment (China) Co., Ltd. (abbr. YNC), which commenced full-scale production of the Ce-1 combine, became the largest half-feeding combine manufacturer in China, with total production capacity of 3,000 units per year.

Meanwhile, in 1999, upon request from Jiangsu Provincial Agricultural Machinery Bureau, trial sales of Japan-manufactured RR6 riding rice transplanter were carried out, and in 2000, the RR series was put on sale, primarily in Jiangsu Province. The Chinese government, in order to promote the mechanization of agriculture, upgraded national subsidies in addition to the individual province's existing subsidy measures. The company then began to put on sale in 2005 the Chinese-specification VP riding rice transplanter series and in 2010 commenced production and sales of the Chinese-specification Global Basic RJ riding rice transplanter series and the AP4 walk-behind rice transplanter.

In 2009 a new technology development center was built at YNC in order to develop domestically manufactured products and improve local development capabilities. From 2012 this center is carrying out product development including combines, rice transplanters and tractors. The facility is working to expand operations in China, such as the start of production and sales of new models of full-feeding combines and tractors.

Yanmar also sought entry into the Chinese market of industrial engines.

In China, where air pollution due to the smoke from thermal power plants and exhaust gas from automobiles is assuming serious proportions, beginning in 2005, policies were hammered out to strengthen regulations on emission gas from agricultural vehicles. From the perspective of the company, this was a major opportunity. Making the most of Yanmar's technological capability, which has met strict environmental standards, in order to supply engines with superior durability, in 2003 established Shandong Shifeng Yanmar Engine Co., Ltd. in Gaotang, Liaocheng, Shandong Province, a joint venture with China's largest agricultural manufacturer, Shifeng Group.

The production of horizontal water-cooled engines began in August 2004, but the joint venture was dissolved in 2005 and the company made a fresh start after being renamed Yanmar Engine (Shandong) Co., Ltd.. In 2009 the company began production of horizontal water-cooled engines at the newly built Qingdao Plant



An international agricultural exhibition in China (2006)

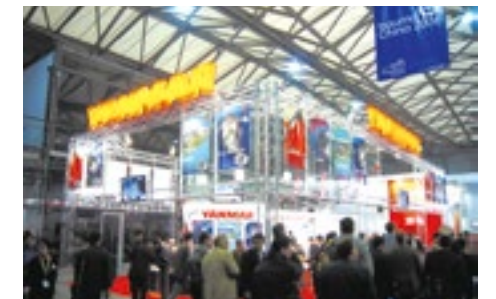

Exhibiting industrial engines at Bauma China, in Shanghai (2006)



Yanmar Engine (Shandong), 2009

in Qingdao Economic and Technological Development Zone. Beginning in 2013, the scale of the business has expanded with the beginning of production of vertical water-cooled engines that are needed to meet the increasing demand for small construction equipment and to cope with the increasingly strict regulations on emission gas.

Among the various manufacturing categories which were developed in China, the most successful was shipbuilding operations. Upon preparing to strengthen large marine engine operations in China, the company converted the marine engine section of the Shanghai representative office into a local subsidiary, establishing Yanmar Engine (Shanghai) Co., Ltd. in 2003.

In the beginning, the main business was the sales and service of marine propulsion and auxiliary engines, and later it expanded into a regional headquarter company. It is now assuming the role of an international procurement base which provides information about superior suppliers within China for global production bases.

In January 2005, the company signed a licensing agreement with Zibo Diesel Engine Parent Company under the umbrella of China National Fisheries (Group) Corporation (present-day China National Agricultural Development Group Co., Ltd.) to produce N330 marine diesel engines. In November 2005, Zibo began producing the 6N330 marine engine at Qingdao Zichai Boyang Diesel Engine Co., Ltd. which it established. As a result, the company entered the Chinese market for the propulsion engines installed in domestic vessels. Further, measures were taken to reduce the production costs of domestic manufactured engines by reverse-import of locally produced parts.



The launch of the 6N330 (2005)

## Development in Asia and emerging economies

In the first half of 2000, the percentage that rice occupied among the total agricultural production of South Korea was exceptionally high and demand for Japanese high-performance agricultural machinery expanded. From 2002 Yanmar Agricultural Equipment in an alliance with a major local agricultural machinery manufacturer has been selling rice transplanters and combines under the Yanmar brand and has sold over 2,000 riding rice transplanters per year.

Seeking further expansion, Yanmar Agricultural Equipment, in order to achieve fine-tuned service in such categories as parts



Seoul International Exhibition of Machinery, Science and Technology For Agriculture

supply and maintenance, in 2005 established Yanmar Agricultural Machinery (Korea) Co., Ltd. in Suwon, Gyonggi Province. This company took as its basic principle of activity “providing service that shows the face of Yanmar.” Since 2007, the company has been concentrating efforts on developing its own sales routes.

The energy system business has also made inroads in Korea. In 2001 an agreement was made with Samchully Co., Ltd. a major Korean city gas company, for selling GHPs. By devoting efforts to sales promotion together with Samchully, as of 2007, the company reached a total number of 3,000 units sold.

Meanwhile, in Southeast Asia where sales and manufacturing operations had continued over many years, a new movement came about. Accompanying economic development in Thailand, mechanization of agriculture was rapidly advancing, and in 2004 in the outskirts of Bangkok, Yanmar Agricultural Machinery (Thailand), Co., Ltd. which sells and services agricultural machinery, was established as a joint venture.

This company sells Japanese tractors based on Thailand-specifications to prominent agriculturalists and large-scale agricultural contractors in the area around Bangkok. Because response was favorable and tractor exports to Thailand reached an annual total of some 4,000 in 2009, a new plant was built in 2011 within the grounds of Yanmar S.P. Co., Ltd. (abbr. YSP) which manufactured horizontal water-cooled engines, and local production of tractors began.



An assembly line at Yanmar S. P.



Yanmar Agricultural Machinery (Korea), 2005



A Yanmar S. P. dealer convention





PT. YKT Gear Indonesia (2001)



PT. Yanmar Indonesia (2013)



A rice transplanter demonstration in India

In Indonesia in 2001, a three-company joint venture between a local gear manufacturer, Kanzaki Kokyukoki and Yanmar established P.T. YKT Gear Indonesia and began producing gears and shafts. In 2013, P.T. Yanmar Indonesia was set up and began producing casting parts. These provide parts and components to supply domestic and overseas Yanmar Group manufacturing bases, and significant cost advantages can be expected.

Yanmar has strategically placed footholds in three BRIC countries—other than China—in preparation for the future.

The company established a representative office in 2005 in the Indian capital of Delhi in order to create a foothold there. On the basis of an advance in local marketing and promotion, in 2011, the company established a local subsidiary, Yanmar India Private Limited (abbr. YIPL). In this major agriculture-based nation, in which 60% of the population is involved in agriculture, YIPL began sales of riding rice transplanters and is moving forward with finding new dealers and setting up new sales bases.

A representative office was set up in Moscow in 2007. In Russia, where installation of electric power infrastructure is insufficient, there is a demand for engines for generators and cogeneration systems, and Yanmar is diligently researching the market for agricultural and construction equipment.

In Indaiatuba, São Paulo, in Brazil, Yanmar South America Industria de Maquinas Ltda. has taken over the operations of its predecessor Yanmar do Brasil S.A. and in 2007 it made a fresh start in carrying out sales and service of vertical water-cooled engines and L model air-cooled diesel engines.

## Succeeding accumulated history and taking it forward

Prior to the 2012 centennial, the employees of the Yanmar Group had two occasions for returning to the founding spirit of the company.

The first was in August 2007, when the company's HB small horizontal water-cooled diesel engine was recognized as a Mechanical Engineering Heritage, newly established by the Japan Society of Mechanical Engineers in commemoration of the 110th anniversary of its founding for the purpose of carefully preserving Japan's domestic machine and technology heritage for the following gen-

erations. The HB model was selected among the very first group and is designated as Number 8 of 25 selected. Among the others so designated are the first-generation Shinkansen bullet trains and the YS11 passenger plane.

The HB model was the world's first small diesel engine, developed in December 1933 through strenuous efforts, and it is the starting point of the company's diesels. Following its development, the company continued to make engines lighter and smaller and they became the power sources for machinery and equipment of various industries. Needless to say, Japan contributed to the mechanization and modernization of various countries around the world. The value of these great achievements has been recognized and this specific acknowledgement is a result.

The second occasion was the unveiling of a monument on the 50th anniversary of the dedication of the Diesel Memorial Japanese Stone Garden.

Yanmar founder and first president Magokichi Yamaoka honored Dr. Rudolf Diesel, inventor of the diesel engine, by donating a Japanese Stone Garden to the city of Augsburg, Germany, in October 1957.

Fifty years had passed since the garden was opened and in March 2008 an unveiling ceremony of a monument honoring the 50th anniversary was held in Wittelsbacher Park in Augsburg, attended by current President Yamaoka, the mayor of Augsburg, the Japanese Consul General in Munich, guests from the MAN Company and descendants of Dr. Diesel.

President Yamaoka delivered a message in honor of the occasion, in which he talked about founding president Magokichi Yamaoka's fateful encounter with the diesel engine and the circumstances that led to the donation of the rock garden, and concluding, "I pray that this garden will remain, for many years to come, a place of recreation and relaxation for the residents of Augsburg."

The following year, on the 50th anniversary of the establishment of sister-city relations between Augsburg and both Nagahama and Amagasaki in Japan, the mayor of Augsburg was invited to both cities to attend various commemorative events.

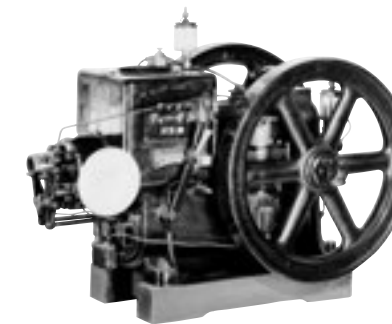

HB model, the world's first commercially viable small diesel engine



Certificate of Mechanical Engineering Heritage (2007)



President Yamaoka (left) and the mayor of Augsburg unveiling a monument on the 50th anniversary of the dedication of the Diesel Memorial Japanese Stone Garden (2008)

## The Great East Japan Earthquake and support for recovery

Just as Japan was recovering from the economic recession resulting from the Lehman Shock, it was stunned by an unprecedented earthquake disaster. The Great East Japan Earthquake occurred on March 11, 2011. The epicenter of the quake was in the Pacific Ocean 130 km east of Miyagi Prefecture. At magnitude 9.0, it was the strongest quake in Japanese recorded history.

The huge tsunami caused by the quake did enormous damage to the Pacific coastal areas of Tohoku and Kanto, setting off a serious nuclear radiation leak at the Fukushima Dai-Ichi Nuclear Power Plant. More than 18,000 people either died or went missing. More than 390,000 homes were either completely or partially destroyed. Altogether, it was the greatest disaster to hit the country in more than a half-century.

Subsequently, President Yamaoka visited Iwate Prefecture and Miyagi Prefecture and wrote in the company's in-house magazine: "There was absolutely no trace of what should have been there—no homes, farmlands, fishing ports, aquaculture farms or machinery. All one could see was the desolation left behind by the tsunami.... Our company deals with primary industries which are particularly susceptible to the powers of nature, but never before have I felt just how devastating those powers could be."



Shizugawa office of Yanmar Marine System hit by the tsunami



Sendai branch of Yanmar Agricultural Equipment Sales destroyed by the earthquake

Four employees of the Yanmar Group lost their lives in the disaster. Four sales and service bases in the disaster zone were completely destroyed. Nine others either collapsed or suffered severe damage. Immediately after the disaster, the company set up the Osaka Headquarters Emergency Center, busily engaged in collecting information updates about the disaster situation and confirmed the personal safety of Yanmar's employees and their family members. The next day the company sent out the first truckload of emergency supplies to the area.

After that, a large number of Group entities participated in planning support activities for the disaster area. Even amid the strong after tremors that continued, the company devoted itself as a single body to recovery efforts. Further, as the Yanmar Group, employees provided donations for relief, power generators and construction machinery. Group employees and athletes from Cerezo Osaka as well as overseas locally incorporated companies took the initiative in collecting donations.

As a result of this major earthquake, Tohoku coastal fisheries suffered devastating damage to their fishing boats, fishing ports and marine products factories and agriculture suffered acute damage in various places. The company worked together with local fishery people in the Japanese oyster farms in Miyagi Prefecture and the bivalve farms in Ofunato, Iwate Prefecture, to promote projects leading to a revitalization of local fisheries. The company also loaned tractors to assist in the desalinization of the soil. The Yanmar Group is continuing to support recovery efforts through its technology and products.

## Foundation Centennial and the introduction of a new Mission Statement

A century has passed since Magokichi Yamaoka founded Yamaoka Hatsudoki Kosakusho (trans. *Yamaoka Engine Company*) in 1912 and the company, which began with a few people working in a small factory in a small town, has grown into the Yanmar Group, which has more than 15,000 employees active around the world. Through the Meiji, Taisho, Showa and Heisei periods in Japan, these hundred years have been a long voyage, with fair winds and foul winds, calm seas and rough seas. Throughout it all, the Group has always had



Setting up the Osaka Headquarters Emergency Center (2011)



The departure of the first truckload of emergency supplies from Osaka



support and cooperation from its customers, clients, business connections and local communities.

While the 100th anniversary is an end point in that long voyage, it is also a starting point for the next 100 years.

In January 2012, after President Takehito Yamaoka presented the annual Business Management Policy, he announced a new “Mission Statement” and “Guiding Principles” based on it.

As a mission of the Yanmar Group, it was already in place in 2005, but the “Promise to Customers” was extensively revised on the occasion of the centennial and the name was changed. This revision had the following goal.

In order for the Yanmar Group to survive in the global market place and achieve continued growth, it will be necessary to strengthen thoroughgoing business competitiveness. This does not mean simply strengthening the foundations or organization of the business. It means that each employee should have a high level of motivation and work to change to a tenacious organization. In order to do this, it is necessary that each and every employee of the Yanmar Group share a common sense of mission and a vision of the action necessary to implement it. In formulating this Statement, young employees of the company organized a project, carefully considered the matter for over a full year and finally came up with a new Mission Statement.

---

### Mission Statement

We strive to provide sustainable solutions  
for needs which are essential to human life.  
We focus on the challenges our customers face  
in food production and harnessing power,  
thereby enriching people's lives for all our tomorrows.

---

The revisions in this Statement mention the specific categories of “food production and harnessing power” as Yanmar's core domains of business and the specific linkage of the Yanmar Group's reason for existing in the reference to furnishing solutions to “the challenges our customers face.”

The Mission Statement is a declaration of the principles and the direction the Yanmar Group should follow from this point forward. It represents a common platform for all employees to share and observe. In order that each individual employee deepens understanding of the Mission and Guiding Principles and therefore takes initiative in putting ideas into action, from July 2012 through March 2013, the company held training sessions at 94 locations in Japan and 15 locations overseas.

### The Centennial Celebration and commemorative projects

On January 24, 2012, the Yanmar 100th Anniversary Celebration Meeting was held at the Portopia Hall, Kobe, Hyogo Prefecture. This magnificent event was attended by 2,500 people, including 1,700 guests from Japan and overseas.

After an impressive performance by a string ensemble, a trumpet fanfare echoed and a video showing the life and accomplishments of founder Magokichi Yamaoka titled “The Dawn of a Century of Yanmar” was shown.

This was followed by an address by President Yamaoka who began by acknowledging the guests, including business connections and others related to the Group, and then paying tribute to predecessors and all of the employees for their contributions to the company's development. Then, quoting the founder's favorite motto, “Grateful to serve for a better world” he reflected on the path that the Group had taken to reach the centennial. He then stated his resolve “to walk together and develop together during the next 100 years.”

Following this, Augsburg's head of economic affairs department Eva Weber and Chairman of Toyota Motor Corporation Fujio Cho each gave heartwarming congratulatory addresses.

During the ceremony, the new Mission Statement was announced. President Yamaoka then declared in a ringing voice, “Under the Yanmar Group's new Mission Statement, around the world, at sea, on land and in the city, in all of these fields of operation that are indispensable for production of food and harnessing of power upon which human life depends, we aim to provide the best solutions to issues our customers face. By means of this, we hope to contribute to the realization of a richer way of life and the development of a



Mission Statement Book



Yanmar 100th Anniversary Celebration Meeting (2012)



President Yamaoka at Yanmar 100th Anniversary Celebration Meeting





Vice Chairman Yasuyuki Yamaoka



Announcement of the new Mission Statement



The finale with the original message song, "Solutioneering Together"

society in which the children of the future can live safely. By doing this, we aim to be a business that everyone will have affection for."

In offering the closing remarks for the ceremony, Vice Chairman Yasuyuki Yamaoka announced the details of the centennial's commemorative projects. The Yanmar Museum and Yanmar Human Resources Development Institute would be established in Nagahama, Shiga Prefecture, birthplace of Magokichi Yamaoka. A new building would be constructed for the Yanmar main office. The finale was an original message song composed especially for the occasion titled "Solutioneering Together," which was sung by two professional singers and an employee chorus group. With the whole assembly singing together, the ceremony was brought to a close.

The Yanmar Museum, which had its grand opening in March 2013, is an interactive museum where visitors can experience the 100 years of Yanmar history and its challenges for the future. In the Agriculture Park, there is a wide variety of workshops for families, including actual rice planting. A year and five months after the museum opened, some 150,000 people had visited the museum. The design harmonizes with the townscape of Nagahama and the building has been complimented for symbolizing the core domains Yanmar operates in—the sea, the land, and the city—and as a result, it has been awarded the BCS Prize from the Japan Federation of Construction Contractors. At the same time, the Yanmar Human Resources Development Institute was completed and now serves as a facility where Yanmar Group employees from around the world come to learn the business philosophy and the goals of the Mission Statement.

In October 2014, the new head office building was completed. With 12 floors above ground and 2 floors underground, the exterior design suggests the bow of a new boat pulling out into the sea. Seeking to be a "Zero CO<sub>2</sub> Emission Building" (ZEB), it employs solar power and the company's own GHPs and cogeneration systems, as well as new technology generation systems. Compared with ordinary office buildings, the plan reduces emissions by 57%.

As if seeing the company off on the path to future growth at the centennial anniversary ceremony, Honorary Chairman Tadao Yamaoka, who had served as president of the company for 35 years, passed away on August 18, 2013 at the age of 87. A farewell ceremony in his honor was held on October 11. Some 2,500 people attended. His favorite work Chopin's Nocturne #2 was performed and offerings of carnations were presented.



Yanmar Museum (2013)



The new head office building, Osaka (2014)



## Starting off on the next 100-year voyage

In March 2013, setting off on the next century, the company launched its new growth strategy: creating a premium brand.

The key words for this activity are “Technology—Service—Hospitality.” They represent the world’s highest-level technology, which the company has cultivated over the past 100 years; service that is thought over from every possible angle; and hospitality which anticipates the needs of customers even before they are aware of those needs. By combining all of the three together, the company will attempt to offer solutions that even exceed the imagination of customers and provide satisfaction to customers that goes one step beyond what they hope for.

The main fields the company has involved itself in are the sea, the land and the city. By means of high-grade engineering and bold planning and proposals, the company aims at advancing as a global enterprise, with the further goal of raising the value of agriculture and fishing as industries.

In July 2013, the company began full-fledged project development and introduced the new “Flying Y” logo, while at the same time presenting a newly developed cruiser, a concept tractor, and marine and agricultural wear lines. The innovative new designs and functions aimed to completely revamp the company image and received broad favorable reviews.

Raising the “Flying Y” as a symbol of its new identity, the Yanmar Group aims to become a front-running global brand in food production and harnessing power, soaring to heights that no one has yet seen.

## History of the Yanmar Group

---

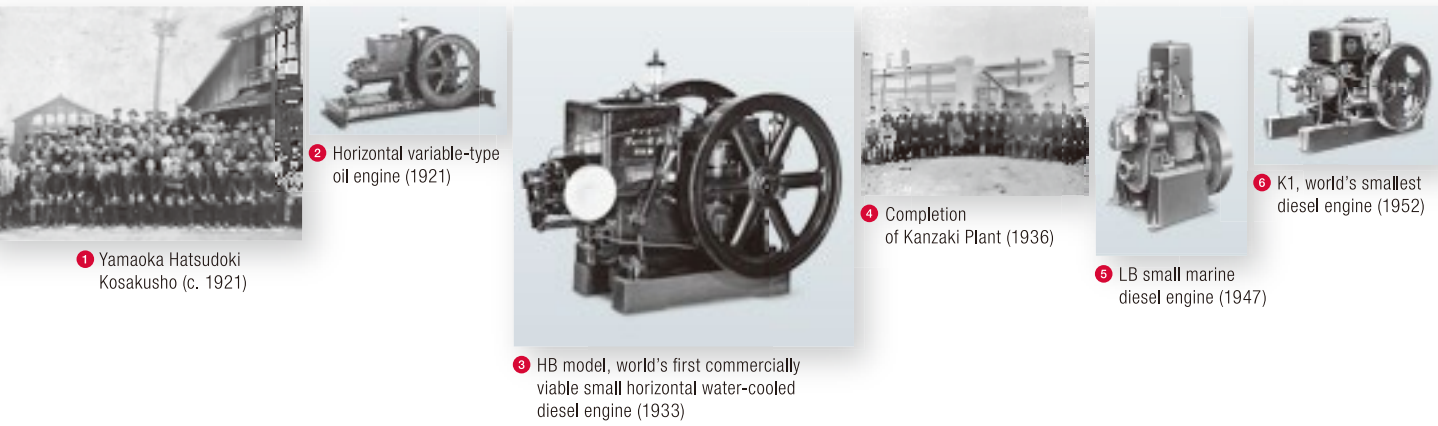

1912 ■ Founded as YAMAOKA HATSUDOKI KOSAKUSHO ①

1919 ■ Branch Office opened in Tokyo, Japan

1921 ■ YANMAR brand name adopted  
 ■ A horizontal oil engine for agricultural applications launched ②  
 ■ Yanmar oil engine-powered rice huller and vertical pump models launched

1924 ■ Branch Office opened in Seoul, Korea

1925 ■ "Yanmar Offset Oil Engine" launched  
 ■ "Yanmar Ford", oil engine for fishing boat applications launched

1927 ■ Tie-up with Philippines-based Libby Plant to produce and sell oil engines

1929 ■ Branch Office opened in Shanghai to expand sales under the locally-branded Yanmar name

1930 ■ A 2-cycle, vertical diesel engine model (5hp) launched

1931 ■ YAMAOKA HATSUDOKI KOSAKUSHO becomes a joint-stock company

1932 ■ President Magokichi Yamaoka impressed by diesel engines at a trade fair in Leipzig, Germany

1933 ■ December 23: HB model, world's first commercially viable small diesel engine (5-6hp), launched ③

1936 ■ KANZAKI PLANT opened in Japan, starting production with S diesel engines ④  
 ■ YAMAOKA INTERNAL COMBUSTION ENGINES CO., LTD. established in Japan

1937 ■ "To conserve fuel is to serve mankind" fundamental principle introduced

1942 ■ NAGAHAMA PLANT opened in Japan

1945 ■ Main production facilities at OSAKA PLANT and AMAGASKAI PLANT heavily damaged during World War II

1947 ■ LB and 2LB small marine engine models (5-7 hp) launched ⑤

1949 ■ NAGAHARA PLANT opened in Japan, starting production with parts for small diesel engine fuel injection pumps

1950 ■ Yamaoka Scholarship Foundation established in Japan

1951 ■ LD (15 hp), 2LD (30 hp) and 3LD (45 hp) vertical water-cooled diesel engine models launched  
 ■ K2 (2-3 hp) small horizontal water-cooled diesel engine model launched

1952 ■ YANMAR DIESEL CO., LTD. name adopted  
 ■ K1, world's smallest 4-cycle horizontal water-cooled diesel engine model (1.5-2Hp), launched ⑥

1953 ■ 4MS marine engine model (120hp) launched  
 ■ Supplied diesel powered systems to the Cosmic Ray Observatory of Tokyo University on Mt. Norikura and Norikura Solar Observatory of Tokyo Astronomical Observatory

1954 ■ Special helicopter sales campaign for the K series launched

1955 ■ President Magokichi Yamaoka awarded the Diesel Gold Medal by the German Inventors' Association

1957 ■ YANMAR DIESEL DO BRASIL LTDA. established in Brazil  
 ■ Awarded the German Merit Cross  
 ■ Diesel Memorial Japanese Stone Garden commemorating Dr. Rudolf Diesel donated to the city of Augsburg, Germany ⑦

1958 ■ JAPAN MARINE EQUIPMENT CO., LTD., joint venture between Yanmar and 7 marine transportation companies, established in Japan

1959 ■ Yanboh & Marboh Mascots Weather Forecast launched in Japan

1961 ■ Rotary engine technology agreement signed with NSU Automobil A.G. and Wankel GmbH. in Germany  
 ■ YANMAR AGRICULTURAL EQUIPMENT CO., LTD. established in Osaka, Japan

1966 ■ YC and YS diesel power tiller series launched

1967 ■ TP 21 and Y30P, the world's first powered rice transplanter models, launched  
 ■ 6G, 240 mm diameter cylinder large engine model (950 hp), launched  
 ■ KINOMOTO PLANT opened in Japan, starting production with the YM273 tractor (23Hp) ⑧

1968 ■ Production of 2W90, vertical water-cooled diesel engine model (20 hp), started  
 ■ Awarded the Deming Prize, the first in the diesel engine industry ⑨

1969 ■ Yanmar Diesel Soccer Club wins The Emperor's Cup All-Japan Soccer Championship Tournament for the first time  
 ■ R220, the world's first rotary outboard engine (22 hp), launched  
 ■ TC500, walk-behind two-row combine model, launched

1971 ■ YS8 (8 hp) and YS12 (12 hp) diesel engines for yachts aimed for European and US markets launched

1972 ■ YANMAR SHIPBUILDING & ENGINEERING CO., LTD. established in Japan to produce fiber-reinforced plastic (FRP) boats ⑩  
 ■ P.T. YANMAR DIESEL INDONESIA established  
 ■ YB600C crawler mini excavator launched ⑪

1975 ■ YB1200 and YTB1200, full-turn crawler mini excavators, launched  
 ■ P.T. YANMAR AGRICULTURAL MACHINERY MANUFACTURING INDONESIA established  
 ■ YANMAR AGRICULTURAL EQUIPMENT CO., LTD. established Kanto Distribution Center in Japan

1976 ■ Exports of YM155D and YM135D small tractors to U.S. began  
 ■ Offices opened in London and Rotterdam  
 ■ Kippu Hoshiki (ticket system) production method implemented at the NAGAHAMA PLANT





12 Marine Hunter FZ22 (1980)

14 Y4GPA outdoor GHP (1987)

15 ViO series excavator (1994)

16 Completion of Biwa Plant (1995)

13 Cogeneration system at Showa Station in Antarctica (1984)



17 Eco Tra series (1995)

18 4TNE 94/98 (1996)

19 Yanmar Agricultural Equipment (China) Co., Ltd. (1997)

20 YSP tractor production line (2011)

21 Founding Centennial Commemoration Finale (2012)

- 1977 ■ Agreement regarding export of tractors concluded with USA-based Deere & Company
- Research & Development Center established in Kyoto, Japan
- 1978 ■ AMAGASAKI PLANT awarded certification by the American Bureau of Shipping (ABS) and Lloyd's Register of Shipping (LR)
- YANMAR THAILAND CO., LTD. established
- 1980 ■ 16ZL, Yanmar's largest output engine model (5,000 hp), launched
- Office opened in Singapore
- FZ22 pleasure boat model launched 12
- Office opened near Chicago
- 1982 ■ AT600S gas turbine launched
- 1983 ■ L, world's smallest air-cooled diesel engine series (4-9 hp), launched
- TN, direct fuel injection vertical water-cooled engine series (11-100 hp), launched
- 1984 ■ Operation of three 6RL-T (200kVA) cogeneration system units started at the Antarctica-based Showa Station 13
- 1985 ■ D27, world's first outboard (27 hp) diesel engine model (27 hp), launched
- T260L-EX, engine (1,500 hp) capable of using low quality fuel with a viscosity rate of 7,000 seconds, developed
- 1987 ■ Entered the air-conditioning market with the launch of gas heat pump systems 14

- 1988 ■ YANMAR MARINE FARM, an aquaculture research facility, established in Japan
- YANMAR EUROPE B.V. established in the Netherlands
- 1989 ■ AMMANN-YANMAR S.A.S. established in France, to produce mini excavators
- 1990 ■ Yanmar Student Essay Contest introduced upon the 30th anniversary of YANMAR AGRICULTURAL EQUIPMENT CO., LTD.
- 1992 ■ Became the first enterprise to be awarded marine diesel engine emission certification by the International Committee of the Lake Constance Switzerland
- 10 millionth diesel engine produced
- 1993 ■ TNE vertical diesel engine series (8.6-84.2 kw) launched
- Osaka Football Club Co., Ltd. and Cerezo Osaka football team established in Japan
- 1994 ■ ViO excavator series launched 15
- Awarded certification for the TNE vertical water-cooled diesel engine series by the California Air Resources Board (CARB)
- 1995 ■ BIWA PLANT opened in Japan to mass-produce vertical diesel engines 16
- EcoTra high-speed tilling tractor series launched 17
- YANMAR CAGIVA S.p.A. (currently: YANMAR ITALY S.p.A.) established by joint venture with Cagiva

- 1996 ■ Awarded certification for the 4TNE94 and 4TNE98 small diesel engines by the U.S. Environmental Protection Agency (EPA) 18
- 1997 ■ YANMAR AGRICULTURAL EQUIPMENT (CHINA) CO., LTD. established to produce combines 19
- 1998 ■ YANMAR MANUFACTURING AMERICA CORPORATION established
- YCP 9800 gas micro cogenerations system launched
- 2000 ■ Research & Development Center established in Maibara, Japan
- 2001 ■ P.T. YKT GEAR INDONESIA established for the production of engine parts
- 2002 ■ Yanmar Group's business plan "Yanmar Evolution Plan" announced
- YANMAR CO., LTD. name adopted
- 2003 ■ YANMAR ENGINE (SHANGHAI) CO., LTD. established
- 2005 ■ Representative Office opened in India
- 2007 ■ YANMAR KOTA KINABALU R&D CENTER SDN. BHD. established in Malaysia as Yanmar's first overseas research center
- HB small horizontal water-cooled diesel engine model, developed in 1933, designated Mechanical Engineering Heritage by The Japan Society of Mechanical Engineers (JSME)
- KOBE CENTER, YANMAR LOGISTICS SERVICE CO., LTD. established in Japan for worldwide parts distribution

- 2008 ■ Commemorative ceremony held in Augsburg, Germany, on the 50th anniversary of the donation of the Diesel Memorial Japanese Stone Garden
- 2009 ■ AMAGASAKI PLANT became the first engine factory to be certified by the German Classification Society (GL)
- 2011 ■ Production of tractors at Thailand-based YANMAR S.P. CO., LTD. started 20
- Facilities damaged during the Great East Japan Earthquake and relief activities carried out
- YANMAR R&D EUROPE S.R.L. established in Florence, Italy as Yanmar's first R&D center in Europe
- 2012 ■ New Mission Statement introduced
- 100th anniversary of the company's founding 21
- PT. YANMAR INDONESIA established for the production of casting parts
- Became the world's first manufacturer to be awarded Tier IV certification for vertical water-cooled diesel engines by the California Air Resources Board (CARB)
- 2013 ■ YANMAR MUSEUM opened in Japan
- YANMAR HOLDINGS CO., LTD. established in Japan
- Yanmar Premium Brand Project launched

## ■ Corporate Profile



YANMAR FLYING-Y BUILDING (2014)



## Expanding 7 Businesses in the 3 Fields of the Sea, the Land, and the City Attempting Innovations in the Areas of Food Production and Harnessing Power

Taking as its base diesel technology from small to large engines, the Yanmar Group has branched out into and developed various fields of production beginning with agriculture and marine products. In 2002, the Yanmar Group was reorganized into 7 domains, with the aims of meeting the needs of customers, not just in Japan but around the globe, and contributing to creating a sustainable society.

YANMAR  
GROUP  
**7**  
Domains



Industrial Engine Business



Large Engine Business



Marine Business



Agricultural Business

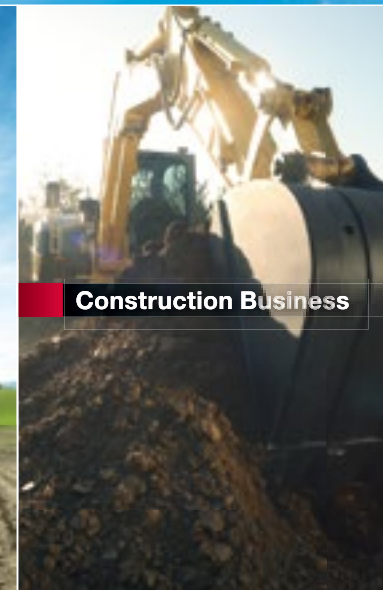

Construction Business



Energy System Business



Component Business

Toward creating an environmentally responsible diesel engine that conforms to even the environmental standards for emissions of the U.S. and Europe, which are the world's most stringent, this domain works on integrating everything from development to production and sales.



Uniting development, production, sales and service, this domain takes as its business model raising the Life Cycle Value of our customers.



Together with providing the world with economical and reliable small and medium-size environmentally responsible engines, this domain is also broadening operations related to FRP boats.



Centered on unified mechanization of rice cultivation by employing the newest technology, this domain is attempting to mechanize various processes in agricultural operations.



As the pioneer in small construction equipment, this domain is achieving safe, comfortable laborsaving equipment for civil engineering and construction.



In the market for air conditioners and power generators, this domain is providing a comfortable living environment through high-efficient, low environmental impact systems.



With core technology in "transmitting power" through such components as gears and hydraulic equipment, this domain is pioneering new markets.





**With technological capability and reliability, we aim at providing solutions to issues of our customers worldwide**

In response to the rapid advance of the world's technology and the demands of an ever-expanding world, we are grappling with raising engine technology and work equipment technology, placing all of our energy into solving the issues customers face.

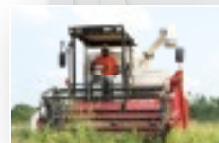

**Industrial Engines**



Vertical Air Cooled Diesel Engines  
**L-N / L-V series**  
Rated output: 3.5~7.4kW  
Displacement: 0.219~0.435L



Air Cooled Diesel Generators  
**YDG series**  
AC output: 2.2~6.6kVA  
Weight: 55~108kg



Horizontal Water Cooled Diesel Engines  
**TF series**  
Rated output: 4.1~11.7kW  
Displacement: 0.382~0.857L



Air Cooled Diesel Generator  
**eG55N**  
AC output: 5.1/5.8kVA  
Weight: 171kg



Vertical Water Cooled Diesel Engines  
**TNV series**  
Rated output: 6.1~88.4kW  
Displacement: 0.569~3.318L



Water Cooled Diesel Generators  
**YEG series**  
AC output: 8.8~74.0kVA  
Weight: 320~1230kg

**Large Engines**

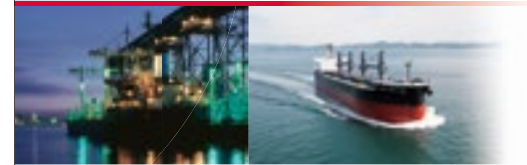

Marine Propulsion Diesel Engines  
**6EY17W**  
Rated output: 374~837kW  
Dry weight: 3880kg



Marine Auxiliary Diesel Engines  
**6EY18(A)LW**  
Rated output: 400~800kW  
Dry weight: 6600kg



Marine Propulsion Diesel Engines  
**6EY22AW**  
Rated output: 885~1370kW  
Dry weight: 10000kg



Marine Auxiliary Diesel Engines  
**6EY22(A)LW**  
Rated output: 660~1370kW  
Dry weight: 11200kg



Marine Propulsion Diesel Engines  
**6EY26W**  
Rated output: 1471~1920kW  
Dry weight: 18500kg



Marine Auxiliary Diesel Engines  
**8N330LW**  
Rated output: 2795~3530kW  
Dry weight: 45000kg

**Marine Products**

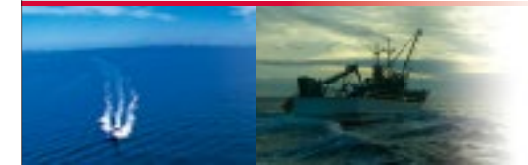

Marine Propulsion Diesel Engines  
**JH series**  
Max. output: 28.7~91.9kW  
Displacement: 1.642~1.995L



Diesel Pleasure Boat  
**FX24EZ**  
Max. output: 84.6kW



Marine Propulsion Diesel Engines  
**8LV series**  
Max. output: 235~272kW  
Displacement: 4.46L



Diesel Pleasure Boat  
**EX33II**  
Max. output: 316kW



Marine Propulsion Diesel Engine  
**12AYM-WGT**  
Max. output: 1340kW  
Displacement: 40.737L



Diesel Fishing Boat  
**DE31D.LC**  
Max. output: 279kW



### Agricultural Equipment



Diesel Tractor  
**EF494T**  
Engine output: 49PS  
Weight: 1520kg



Mini Tillers  
**MRT series**  
Gasoline engine output: 4.2~6.3PS  
Cultivating width: 500mm



Power Tillers  
**BROMO series**  
Gasoline engine output: 8.5PS



Diesel Tractors  
**EG400 series**  
Engine output: 37~53PS  
Weight: 1590~2155kg



Walk-behind Rice Transplanters  
**AP series**  
4~6 rows planted at a time  
Engine output: 3.5PS



Combine Harvesters  
**AG6100R/6114R/7114R**  
Engine output: 100.3~113.9PS  
Reaping row: 6~7



Diesel Tractors  
**EG-PRO series**  
Engine output: 48~105PS  
Weight: 2090~3595kg



Rice Transplanters  
**RG series/VP series**  
5~8 rows planted at a time  
Engine output: 21.3PS



Combine Harvesters  
**AW series**  
Engine output: 70~82PS  
Reaping width: 2000mm

### Components



Integrated Hydro-Mechanical Transmission  
**I-HMT**  
Displacement: 33.8cc/rev(Pump & Motor)  
Gear ratio: 0~2(Infinity), Weight: 24kg



Marine Gears  
**YXH240 series**  
Transmission Capacity: Max. 3604N·m  
Reduction ratio: 4.89~6.95, Weight: 1280kg



Gear Shaving Machines  
**GSX series**  
Workpiece Diameter: 25~350mm  
Weight: 4800~5500kg

### Construction Equipment

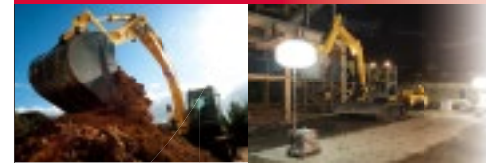

Crawler Excavator  
**SV08-1A**  
Engine output: 7.7kW  
Max. digging depth: 1500mm



Crawler Excavator  
**SV100-2**  
Engine output: 54.7kW  
Max. digging depth: 4530mm



Crawler Excavator  
**Vi017**  
Engine output: 10.1kW  
Max. digging depth: 2200mm



Crawler Carrier  
**C30R-2B**  
Engine output: 24.6kW  
Max. payload: 2500kg



Crawler Excavator  
**Vi055-6**  
Engine output: 33.4kW  
Max. digging depth: 3900mm



Wheel Loader  
**V3-6**  
Engine output: 22.6kW  
Std. bucket capacity: 0.4m³

### Energy Systems



GHP Air-conditioning Systems (Outdoor Units)  
**J series**  
Cooling capacity: 45~85kW  
Heating capacity: 50~95kW



Emergency Use Generators  
**AP series**  
Rated output: 20~500kW  
Voltage: 200/220V



GHP Chiller (Hydro Type) Air-conditioning System  
**ECWP710J**  
Cooling capacity: 71.0kW  
Heating capacity: 80.0kW



Cogeneration Systems  
**EPG series**  
Rated output: 370~800kW  
Voltage: 6.6kV



Cogeneration Packages  
**CP series**  
Output (50/60Hz): 5~35kW  
Overall efficiency: 85%



Gas Turbines  
**AT series**  
Rated output: 228~2133kW  
Dry weight: 440~4500kg



**YANMAR HOLDINGS CO., LTD.**

**Trade Name** : Yanmar Holdings Co., Ltd.  
**Head Office** : 1-32, Chayamachi, Kita-ku,  
 Osaka, 530-8311, Japan  
**Established** : April 1, 2013  
**Capital** : 90 million yen  
**Employees** : 16,678 (as of March 2014)  
 (Consolidated)

**YANMAR CO., LTD.**

**Trade Name** : Yanmar Co., Ltd.  
**Head Office** : 1-32, Chayamachi, Kita-ku,  
 Osaka, 530-8311, Japan  
**Tokyo Branch Office** : 2-1-1 Yaesu, Chuo-ku,  
 Tokyo, 104-8486, Japan  
**Founded** : March 22, 1912  
**Established** : February 11, 1931  
**Capital** : 6.3 billion yen  
**Employees** : 3,313 (as of March 2014)



Head Office



Tokyo Office

**Major Group Entities (Japan)**

◎ Power System Operations Business

**Biwa Plant**



Manufacturing of industrial engines

**Kinomoto Plant**



Manufacturing of industrial engines and related parts

**Omori Plant**



Manufacturing of precision equipment

**Nagahara Plant**



Manufacturing of precision equipment

**Tsukaguchi Plant**



Manufacturing of small and medium marine engines

◎ Large Power Products Operations Business

**Amagasaki Plant**



Manufacturing of large engines

**Research & Development Center**



Research and development of products and related technology

**Marine Farm**



Research and development related to aquaculture

**Yanmar Human Resources Development Institute**



**Yanmar Museum**



Interactive museum presenting the company's history and products

**Group Companies (Japan)**

◎ Engine Business

**Yanmar Casting Technology Co., Ltd.**

Manufacturing and sales of cast iron products

**Yanmar Engineering Co., Ltd.**

Installation and maintenance of internal combustion engines and parts

◎ Marine Business

**Yanmar Marine System Co., Ltd.**

Sales and service of marine engines and pleasure boats

**Yanmar Shipbuilding & Engineering Co., Ltd.**

Manufacturing of FRP boats, fish tanks and piers

◎ Agricultural Business

**Yanmar Agri Japan Co., Ltd.**

Sales of agricultural machinery and equipment

**Yanmar Agricultural Machinery Manufacturing Co., Ltd.**

Manufacturing of agricultural machinery

**New Delta Industrial Co., Ltd.**

Manufacturing of agricultural machinery

**Kyoritsu Irrigate Co., Ltd.**

Manufacturing and sales of sprinklers



Yanmar Shipbuilding & Engineering Co., Ltd.



Yanmar Agricultural Machinery Manufacturing Co., Ltd.



Yanmar Construction Equipment Co., Ltd.



Yanmar Energy System Mfg. Co., Ltd.

**Yanmar Green System Co., Ltd.**

Design, implementation and maintenance of agricultural facilities

**Yanmar Heli & Agri Co., Ltd.**

Development, manufacturing and sales of helicopters for agricultural use

**Yanmar Agricultural Innovation Co., Ltd.**

Manufacturing, processing and sales of agricultural products, and agricultural management

◎ Construction Business

**Yanmar Construction Equipment Co., Ltd.**

Manufacturing and sales of construction equipment

◎ Energy System Business

**Yanmar Energy System Co., Ltd.**

Development and sales of air-conditioning and power generation systems

**Yanmar Energy System Mfg. Co., Ltd.**

Manufacturing of air-conditioning and power generation systems

**Kohrin Engineering Co., Ltd.**

Manufacturing of cogeneration systems and power generation systems

◎ Component Business

**Kanzaki Kokyukoki Mfg. Co., Ltd.**

Manufacturing and sales of gears, transmissions, hydraulic equipment and machine tools

◎ Shared Services

**Yanmar Business Service Co., Ltd.**

Building maintenance, construction and supervision, and travel business

**Yanmar Information System Service Co., Ltd.**

Development, support and operation of information systems

**Yanmar Technical Service Co., Ltd.**

Technical documentation services

**Yanmar Credit Service Co., Ltd.**

Credit, leasing and installment

**Yanmar Logistics Service Co., Ltd.**

Domestic delivery of Yanmar products and parts, storage, and import-export handling

**Seirei Total Service Co., Ltd.**

Product shipping

◎ Sales Companies

**Yanmar Okinawa Co., Ltd.**

Sales and service of Yanmar products

**Yanmar Sangyo Co., Ltd.**

Sales of oil and batteries, and sales and service of residential and facility equipment



Group Companies (Overseas)

Europe

**Yanmar Europe B.V.**

Sales of engines, agricultural machinery and parts

**Yanmar Marine International B.V.**

Manufacturing and sales of engines for pleasure boats

**Yanmar International Europe B.V.**

European regional headquarter company

**Yanmar Construction Equipment Europe S.A.S.**

Manufacturing and sales of construction equipment

**Yanmar Italy S.p.A.**

Manufacturing and sales of air-cooled diesel engines

**Yanmar Benelux B.V.**

Sales of marine and industrial-use diesel engines

**Yanmar Norge A.S.**

Sales of diesel engines for boats

**Yanmar Sverige A.B.**

Sales of marine and industrial-use diesel engines

**Yanmar Equipment Iberica, S.L.**

Sales of marine diesel engines

**Yanmar RUS LLC**

Sales for Russia

**Vetus B.V.**

Sales of engines and parts for pleasure boats

**Yanmar R&D Europe S.R.L.**

Research on renewable energy systems and electric and hybrid machinery

North America / Latin America

**Yanmar America Corporation**

Manufacturing and sales of tractors, and sales of construction equipment, energy systems, industrial and marine engines

**Tuff Torq Corporation**

Manufacturing and sales of transmissions and transaxles

**Transaxle Manufacturing of America Corporation**

Manufacturing and sales of transmissions and transaxles

**Mastry Engine Center LLC, A Yanmar Company**

Sales of engines and parts for pleasure boats

**Yanmar South America Industria de Maquinas Ltda.**

Sales for South America



Yanmar Europe B.V.



Yanmar America Corporation



Yanmar Italy S.p.A.



Tuff Torq Corporation



Yanmar Construction Equipment Europe S.A.S.



Yanmar Asia (Singapore) Corporation Pte. Ltd.

Asia Pacific

**Yanmar Asia (Singapore) Corporation Pte. Ltd.**

Sales of engines and parts

**Yanmar S.P. Co., Ltd.**

Manufacturing and sales of diesel engines and tractors

**Yanmar Capital (Thailand) Co., Ltd.**

Sales finance company for Thailand

**P.T. Yanmar Diesel Indonesia**

Manufacturing and sales of marine and industrial-use diesel engines

**P.T. Yanmar Agricultural Machinery Manufacturing Indonesia**

Manufacturing and sales of agricultural machinery



Yanmar S.P. Co., Ltd.



Yanmar Kota Kinabalu R&D Center Sdn. Bhd.



P.T. Yanmar Diesel Indonesia



Yanmar Agricultural Equipment (China) Co., Ltd.



P.T. Yanmar Indonesia



Yanmar Engine (Shandong) Co., Ltd.

**P.T. YKT Gear Indonesia**

Manufacturing of engine parts

**PT. Yanmar Indonesia**

Manufacturing of cast parts

**Yanmar India Private Limited**

Sales for India

**Yanmar Agricultural Machinery (Korea) Co., Ltd.**

Sales and service of agricultural machinery

**Yanmar Kota Kinabalu R&D Center Sdn. Bhd.**

Research and development of biodiesel fuel related technology

**Yanmar Engine (Shanghai) Co., Ltd.**

Sales and service of marine diesel engines

**Yanmar Agricultural Equipment (China) Co., Ltd.**

Manufacturing and sales of agricultural machinery

**Yanmar Engine (Shandong) Co., Ltd.**

Manufacturing of industrial diesel engines and construction equipment

**Harbin Yanmar Agricultural Equipment Co., Ltd.**

Sales and service of agricultural machinery



## Protecting the global environment and supporting the development of the global society

Yanmar is actively addressing the issue of coexisting with nature to protect the global environment. Further, by supporting educational activities and sports activities, we are hoping to contribute to the making of a society in which people's hopes can be realized.

The Yanmar Group has identified the protection of the global environment as one of the most important management policies, and as a result, the company is promoting environmental management and sensitivity toward the environment as a fundamental part of its business activities.

### Deciding on the Group's Environmental Vision 2020

The Yanmar Group has drawn up its Environmental Vision 2020 as we approach FY2020, the international target year for reducing global-warming gases. The plan has set the direction for the Group's environmental activities.

#### Yanmar Group Environmental Vision 2020

The Yanmar Group is conscious of the fact it handles products that can have an environmental impact. As a pioneer in energy technology, we are working towards the realization of a sustainable society.

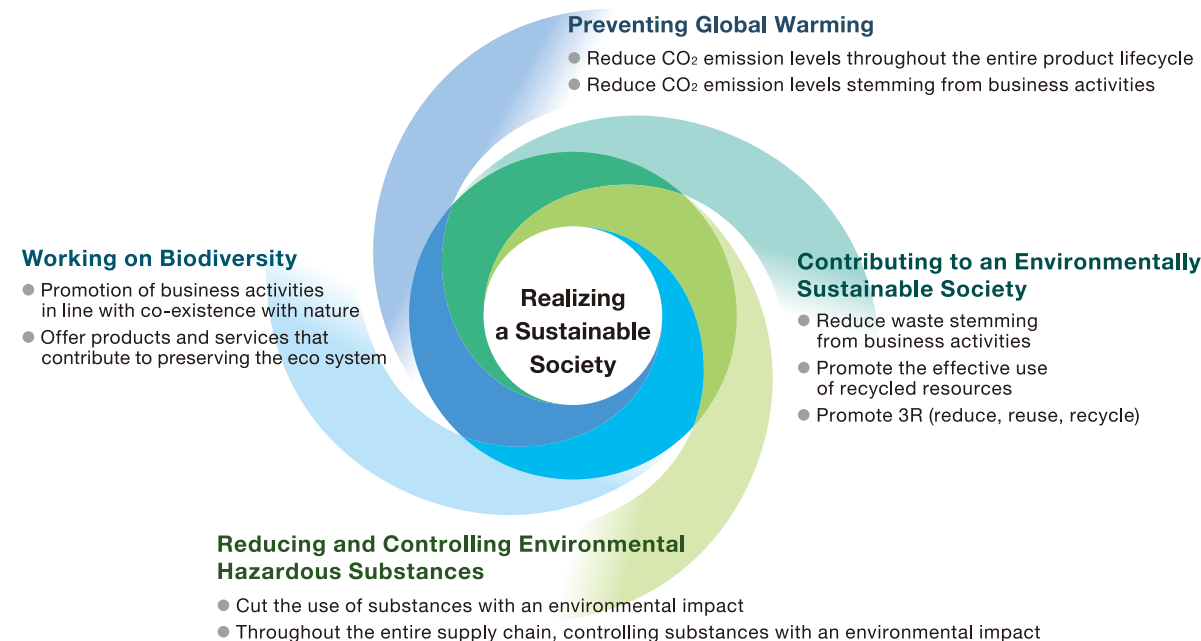

### Yamaoka Scholarship Foundation

Yanmar's founder Magokichi Yamaoka established the Yamaoka Scholarship Foundation in 1950 to develop human resources capable of contributing to world peace and prosperity and cultural improvement. So far over 5,300 people have received scholarships from the Foundation and moved on to perform active roles in various fields.



### Yanmar Student Essay Contest

In 1990 the Yanmar Group initiated the Yanmar Student Essay Contest calling for submission of essays from students regarding the future of agriculture and farming villages. The academic papers and student essays that are submitted every year provide opinions filled with ideals and youthful vision.



### J League Club : Cerezo Osaka

Originally the Yanmar Diesel Soccer Club, current J League team Cerezo Osaka has captured the heart of many legions of fans. Yanmar supports the activities and daily growth and development of Cerezo Osaka together with Osaka City and many companies as part of our effort to help promote sports culture in the local community.



©OSAKA F.C.

### Yanmar Museum

The Yanmar Museum was established on the occasion of Yanmar's centennial in founder Magokichi Yamaoka's home region of Nagahama, Shiga Prefecture. The Museum offers a wealth of exhibits and workshops that give visitors an experience they cannot find anywhere else.





TRANSLATION: James M.Vardaman and Mieko Nakajima, Timo Associates,Inc.,  
ART DIRECTION AND DESIGN: Kazuhiko Miki, Ampersand Works and HOTART  
EDITING: Junko Kawakami, LETRAS  
PROOFREADING: Yoshiko Otaki and Ichiro Ozu

#### COOPERATION

The publisher would like to thank the following for their cooperation for this book:

Nikkei Inc.  
The Asahi Shimbun Company

#### PHOTO CREDITS

P. 17 TOP: Shiga prefectural library  
P. 17 BOTTOM: courtesy of Satoshi Otomo  
P. 19: Osaka Museum of History  
P. 23: The Kansai Electric Power Company, Incorporated  
P. 27: amanaimages  
P. 50: Sankei Shimbun Co., Ltd.  
P. 82 TOP AND BOTTOM: The Mainichi Newspapers  
P. 102 TOP: The Japan Times, Dec. 2. 1973 BOTTOM: The Japan Times, Apr. 30. 1981  
P. 128 TOP: AP-Aflo  
P. 137 TOP: The Japan Times, Dec. 9. 1993  
P. 154 TOP: AFP-Jiji Press  
P. 154 BOTTOM: EPA-Jiji Press  
P. 190 LEFT: courtesy of Isao Takahashi

## 100 YEARS OF YANMAR 1912-2012

by YANMAR CO.,LTD.

Copyright ©2015 by YANMAR CO.,LTD.

All rights reserved.

This book is an English translation edition of *Yanmar 100 nen-sbi*,  
written in Japanese.

Copyright ©2014 by YANMAR CO., LTD.

Originally published in Japan by Nikkei Publishing Inc., a member of  
NIKKEI Group.

This translated edition published in Japan by  
Nikkei Publishing Inc., a member of NIKKEI Group  
by direct arrangement with YANMAR CO.,LTD.

All rights reserved.